

TECHNICAL MANUAL

OPERATOR, ORGANIZATIONAL, DIRECT  
SUPPORT & GENERAL SUPPORT  
MAINTENANCE MANUAL INCLUDING  
REPAIR PARTS LIST

FOR

SHOP EQUIPMENT, GENERAL PURPOSE  
REPAIR, SEMITRAILER MOUNTED

MODEL: SGPRSMD

(NSN 4940-01-006-3229)

---

**MARCH 1984**

WARNING PAGE

Always remove the radiator cap slowly to permit any pressure to escape.

Do not smoke or use open flame in the vicinity when servicing the batteries. Batteries generate hydrogen, a highly explosive gas.

Static electricity and leakage currents from electric equipment can build up in the shop set and cause injury or death to personnel unless the equipment is properly grounded.

Always wear protective glasses when using compressed air to clean radiator air passages. Injury to the eyes may result from failure to observe this warning.

Before performing any maintenance procedures on the electrical system, see that all external power is disconnected from the shop set.

INJURY OR DEATH CAN RESULT IF SHOP SET IS NOT PROPERLY GROUNDED.

Wear asbestos gloves when handling heated flywheel to avoid serious burns.

The Diesel fuel used in the engine for the Dynamotor-Welder is combustible. Use caution when draining/filling fuel tank and working on the fuel system. Extinguish all smoking materials and do not allow sparks or open flame near the fuel tank and fuel system.

Change

HEADQUARTERS  
DEPARTMENT OF THE ARMY  
Washington, DC 7 January 1991

No. 1

Operator's, Organizational, Direct Support and  
General Support Maintenance Manual  
Including Repair Parts List  
for  
SHOP EQUIPMENT,  
GENERAL PURPOSE REPAIR,  
SEMITRAILER MOUNTED,  
MODEL: SGPRSMD  
(NSN 4940-01-006-3229)

TM9-4940-549-14&P, 12 March 1984, is changed as follows:

Front Cover. In the title, change "ORGANIZATIONAL" to "UNIT." Under "(NSN 4940-01-006-3229)" add "(SERIAL NUMBER RANGE S-11-204 THROUGH S-11-368)."

WARNING Page. After last warning add "For first aid refer to FM 21-11."

Inside Cover Page. Under "REPORTING ERRORS AND RECOMMENDING IMPROVEMENTS," change the attention line to "ATTN: AMSMC-MAS, Rock Island, IL 61299-6000." In the title, change "Organizational" to "Unit." Under "(NSN 4940-01-006-3229)" add "(Serial No. Range S-11-204 through S-11-368)."

Instructions for Requisitioning Parts Page. In steps 1 and 7a, delete the number "98255."

Page 1-1. Paragraph 1-3 is rescinded. Paragraph 1-7, change the attention line of the address to "ATTN: AMSMC-QAD, Rock Island, IL 61299-6000." After paragraph 1-7, add new paragraph 1-7.1 as follows:

1-7.1 Corrosion Prevention and Control. Corrosion Prevention and Control (CPC) of Army materiel is a continuing concern. It is important that any corrosion problems with this item be reported so that the problem can be corrected and improvements can be made to prevent the problem in future items. While corrosion is typically associated with rusting of metals, it can also include deterioration of other materials such as rubber and plastic. Unusual cracking, softening, swelling, or breaking of these materials may be a corrosion problem. If a corrosion problem is identified, it can be reported using Standard Form 368, Product Quality Deficiency Report. Use of key words such as "corrosion," "rust," "deterioration," or "cracking" will assure that the information is identified as a CPC problem. The form should be submitted to:

Commander  
U.S. Army Armament, Munitions and Chemical Command  
ATTN: AMSMC-QAD/\Customer Feedback Center  
Rock Island, Illinois 61299-6000

**TM 9-4940-549-14&P**

Page 2-7. The untitled callout at the upper right of the illustration should be entitled "FREQUENCY METER".

Page 3-1. Paragraph 3-4, after first sentence add "Leakage definitions for operator PMCS shall be classified as follows:

- CLASS I Seeping of fluid (as indicated by wetness or discoloration) not great enough to form drops.
- CLASS II Leakage of fluid great enough to form drops, but not enough to cause drops to drip from an item being checked/inspected.
- CLASS III Leakage of fluid great enough to form drops that drip from the item being checked/inspected."

Page 3-2. Paragraph 3-4, add third sentence as follows: "Check equipment items in item number sequence at the following intervals: B - Before Operation; D - During Operation; A - After Operation; W - Weekly Preventive Checks." Delete old table 3-1 and add new table 3-1 as follows:

Table 3-1. Operator Preventive Maintenance Checks and Services

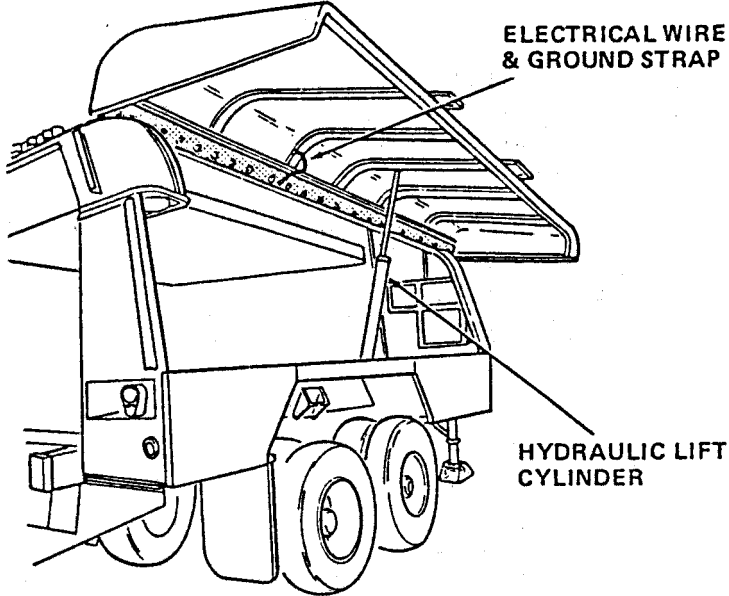
Item No.	Interval				Item to be Inspected Procedure	Equipment Is Not Ready/ Available if:
	B	D	A	W		
1	•		•	•	<p>Shop Equipment Body:</p> <ul style="list-style-type: none"> <li>• Check for body damage (i.e., dents, cracks, rust, and bare metal).</li> <li>• Check for broken or loose side door hinges or broken locking devices.</li> </ul>  <ul style="list-style-type: none"> <li>• Check lift cylinders of side doors for leakage of hydraulic fluid</li> <li>• Check vehicular lights and lenses for breakage or burned out bulbs.</li> <li>• Check electrical wiring on side doors and end panel for frayed or cut wiring especially in the hinged areas.</li> <li>• Check side doors, end panel, and latches for ease of operation.</li> </ul>	<p>Equipment cannot be secured or side door hinges are broken or loose.</p> <p>Lift cylinder develops a leak.</p> <p>Burned, bare, or frayed wiring.</p>

Table 3-1. Operator Preventive Maintenance Checks and Services - (Cont'd)

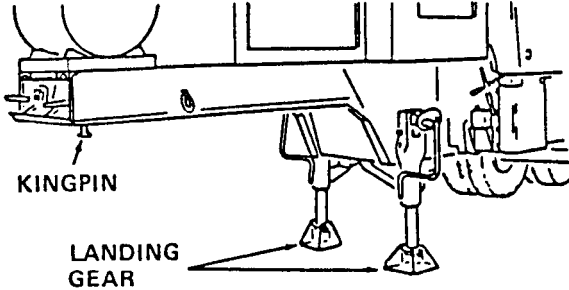
Item No.	Interval				Item to be Inspected Procedure	Equipment Is Not Ready/ Available if:
	B	D	A	W		
2	•		•	•	<p>Equipment Chassis Trailer:</p> <ul style="list-style-type: none"> <li>• Check tires and wheels. Look for cut or badly worn tires. Check tire pressure for 75 lbs (check tires when cold) and add air as necessary. Wheels should be securely tightened to studs on axle hub. Signs of rust at lug nuts indicate that the lug nut is loose. All lug nuts should be checked by hand using lug nut wrench and bar.</li> <li>• Check power connector for corrosion, and test electrical operation for lighting and turn signal operation with prime mover vehicle.</li> <li>• Inspect and test brake system of chassis trailer. Air tanks are to be drained daily after operation of equipment. Report brake failure or signs of air or hydraulic leaks to unit level maintenance.</li> <li>• Check frame for signs of damage, cracks in welds and material, or bent framework. Check for rust and remove with wire brush or sandpaper; then spot paint bare metal.</li> <li>• Check landing gear for proper operation and kingpin for wear and lubrication.</li> </ul>	<p>Tire mounted on trailer is flat or is excessively worn. Wheel mounted on axle is damaged.</p> <p>Electrical system inoperative.</p> <p>Brakes reveal air leak or hydraulic leak or brakes are seized or inoperative.</p> <p>Frame cracked, broken, bent, or rusting through.</p> <p>Loose or missing king-pin.</p>
						

Table 3-1. Operator Preventive Maintenance Checks and Services - (Cont'd)

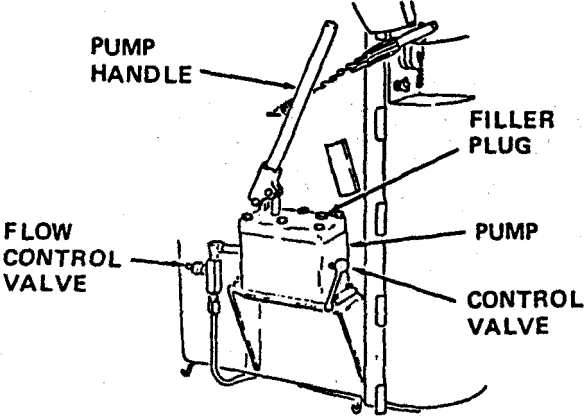
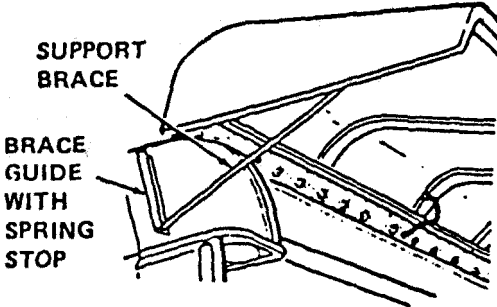
Item No.	Interval				Item to be Inspected Procedure	Equipment Is Not Ready/ Available if:
	B	D	A	W		
3	•		•	•	<p>Hydraulic Pumps for Side Doors:</p> <ul style="list-style-type: none"> <li>• Check for leakage, proper hydraulic oil level (check with doors in lowered position), and operation.</li> <li>• Check controls for completeness and operation.</li> </ul> 	Inoperative or leak exists.
4	•	•	•	•	<p>Door Braces, Top Side Doors:</p> <ul style="list-style-type: none"> <li>• Check for broken, bent, and missing door braces.</li> <li>• Inspect for rust and lube on brace guides.</li> <li>• Inspect for missing or broken spring stops.</li> </ul> 	Missing or bent braces.

Table 3-1. Operator Preventive Maintenance Checks and Services - (Cont'd)

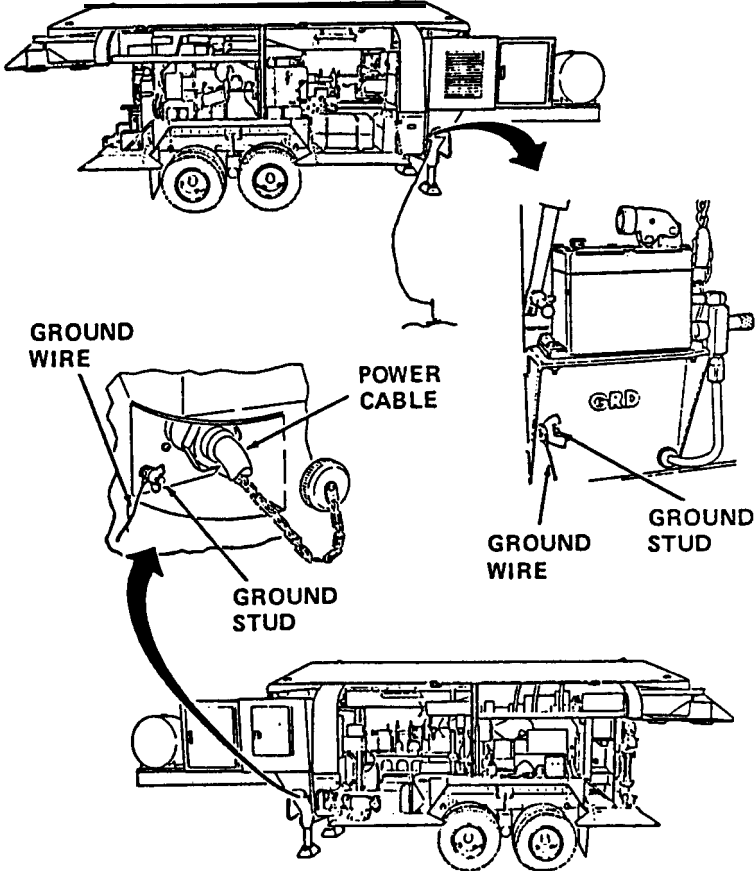
Item No.	Interval				Item to be Inspected Procedure	Equipment Is Not Ready/ Available if:
	B	D	A	W		
5	•				<p>Fire Extinguisher:</p> <ul style="list-style-type: none"> <li>Inspect seal. If broken, have fire extinguisher reweighed and sealed at fire department.</li> </ul>	Missing or empty fire extinguisher.
6	•	•	•	•	<p>Electrical Ground:</p> <ul style="list-style-type: none"> <li>Check ground rod and components for missing or unserviceable condition.</li> </ul> 	Ground equipment missing or unserviceable.



Table 3-1. Operator Preventive Maintenance Checks and Services - (Cont'd)

Item No.	Interval				Item to be Inspected Procedure	Equipment Is Not Ready/ Available if:
	B	D	A	W		
7	•	•	•	•	<p>Power Cable:</p> <ul style="list-style-type: none"> <li>● Inspect cable for cuts, wear, and burned areas.</li> <li>• Inspect connectors for corrosion, bent or broken pins, and stripped mounting threads.</li> <li>● Check power cable connector on vehicle for cracks, corrosion, and stripped threads. Check cap for seal and chain.</li> </ul>	Power cable or connector damaged, creating electrical short.
8	•	•			<p>Welder Controls and Instruments:</p> <ul style="list-style-type: none"> <li>• Inspect for damage and loose mounting. With unit operating, check for proper operation.</li> </ul> <p>Normal operating readings are as follows:                      AC Voltmeter: 240-volts                      Frequency Meter: 50-60 hertz                      DC Voltmeter: Terminal voltage                      DC Ammeter: Not to exceed 300 amps</p>	Burned or damaged wiring or components.

Table 3-1. Operator Preventive Maintenance Checks and Services - (Cont'd)

Item No.	Interval				Item to be Inspected Procedure	Equipment Is Not Ready/ Available if:
	B	D	A	W		
8 (Cont)					<p>Welder Controls and Instruments:</p> <ul style="list-style-type: none"> <li>• Inspect for damage and loose mounting. With unit operating, check for proper operation.</li> </ul> <p>Normal operating readings are as follows:                      Coolant temperature gage: 180-195°F                      Oil pressure: 40-60 psi                      Battery alternator voltage indicator: pointer to green                      Tachometer: 1,800 rpm at 60 hertz                      High Coolant Temperature Warning Light and Low Oil Pressure Warning Light is off.</p>	

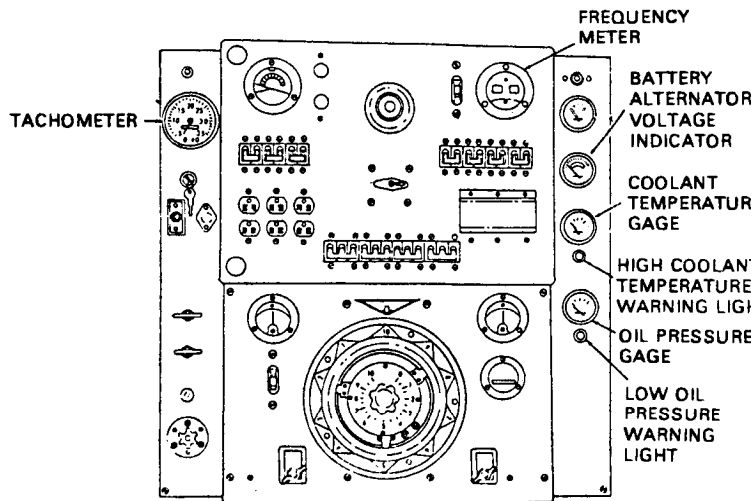


Table 3-1. Operator Preventive Maintenance Checks and Services - (Cont'd)

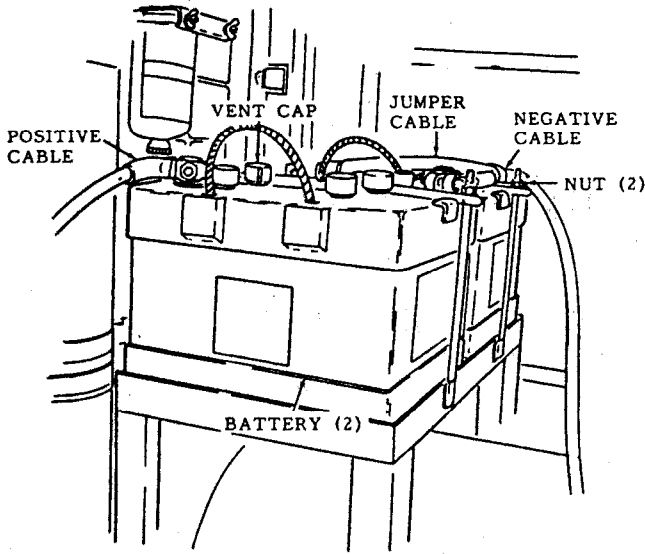
Item No.	Interval				Item to be Inspected Procedure	Equipment Is Not Ready/ Available if:
	B	D	A	W		
9	•			•	<p>Power Unit:</p> <ul style="list-style-type: none"> <li>• Check batteries daily before operation. Ensure electrolyte levels are full (up to the split ring). Check for loose terminals and corrosion in battery compartment. Remove corrosion. Remove batteries to fill with electrolyte (para 4-7).</li> </ul>  <ul style="list-style-type: none"> <li>• Check engine coolant level. Fill radiator as necessary, Proper coolant level is 2 inches below filler neck.</li> <li>• Check engine oil dipstick for safe oil level before operation. Add oil as necessary. Check for oil leaks</li> <li>• Drain water accumulated in the fuel filter daily.</li> </ul>	<p>Batteries dead or leak battery acid.</p> <p>Radiator leaks,</p> <p>Engine oil level below safe mark. There are any Class II leaks.</p>

Table 3-1. Operator Preventive Maintenance Checks and Services - (Cont'd)

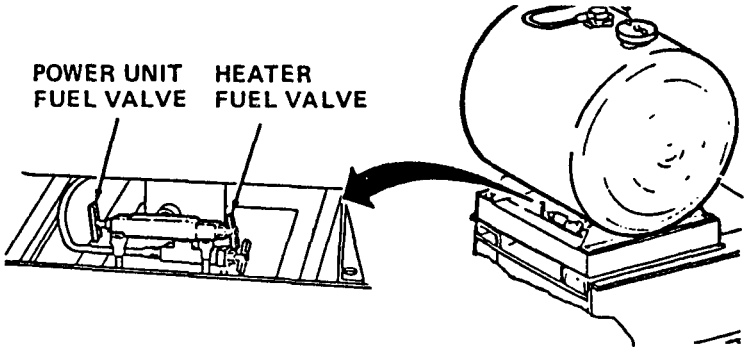
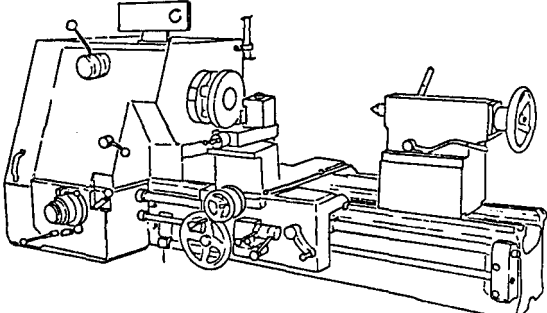
Item No.	Interval				Item to be Inspected Procedure	Equipment Is Not Ready/ Available if:
	B	D	A	W		
9	•	•		•	<p>Power Unit - (Cont'd)</p> <ul style="list-style-type: none"> <li>● Check engine coolant control shutters in front of the radiator for proper operation and that the shutters do not bind.</li> <li>● Check power unit fuel level, add fuel as required. Tank should be full both during and after equipment operations daily. Ensure fuel valve to the power unit is in the open position.</li> </ul> 	<p>Shutters become inoperative.</p> <p>Fuel tanks or lines leak.</p>
10	•	•		•	<p>Engine Lathe:</p> <ul style="list-style-type: none"> <li>• Check lathe for proper operation of controls .</li> <li>• Check for unusual noises or vibration during lathe operation.</li> <li>• Check safety brake operation.</li> <li>• Check unit for loose attachments.</li> </ul> 	<p>Lathe is inoperative or develops unusual noises or vibration.</p>

Table 3-1. Operator Preventive Maintenance Checks and Services - (Cont'd)

Item No.	Interval				Item to be Inspected Procedure	Equipment Is Not Ready/ Available if:
	B	D	A	W		
11	•	•			<p>Electrical Components and Outlets:</p> <ul style="list-style-type: none"> <li>• Check all lights for proper operation and damage. Replace lamps as required.</li> <li>• Check electrical fans for proper operation.</li> <li>• Check electric outlets and exposed electrical wiring for any damage.</li> </ul>	Electrical fire or short exists.
12	•		•	•	<p>Air Compressor System:</p> <ul style="list-style-type: none"> <li>• Check oil level on sight glass prior to operation. Oil level should be at center line of oil gage.</li> </ul> <p style="text-align: center;"><b>CAUTION</b></p> <p>Do not operate air compressor when the oil level is 1/16th inch below center line.</p> <ul style="list-style-type: none"> <li>• Check air tank drain valve. This valve should remain in the open position when air compressor system is not in use to drain moisture from the air tank. Close this valve clockwise prior to operation.</li> <li>• Check air pressure gage during operation. The compressor should start when the air pressure is less than 125 psi and shut-off at 150 psi.</li> </ul>	

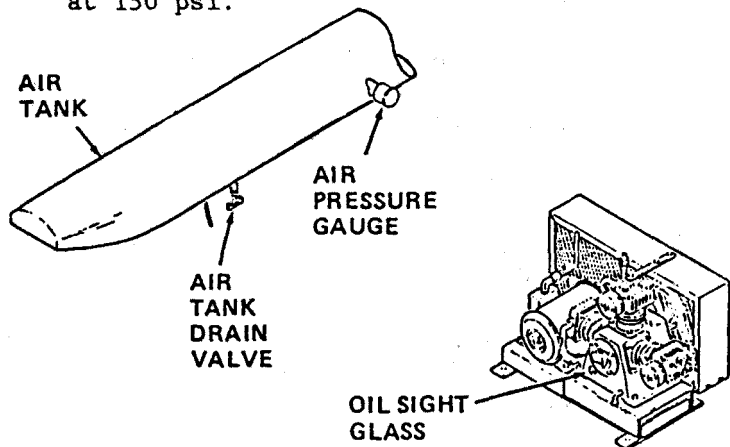
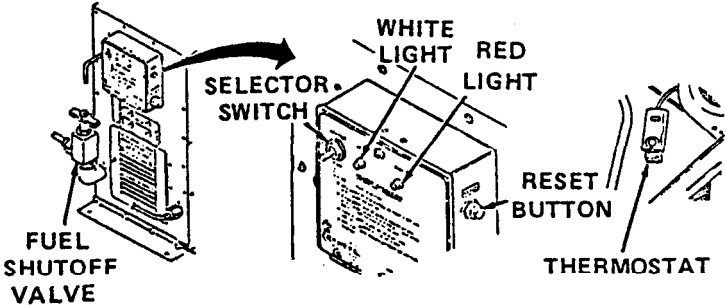


Table 3-1. Operator Preventive Maintenance Checks and Services - (Cont'd)

Item No.	Interval				Item to be Inspected Procedure	Equipment Is Not Ready/ Available if:
	B	D	A	W		
13	•	•	•	•	<p>Heater System:</p> <ul style="list-style-type: none"> <li>• Check fuel shut off valve, lines, pump, and heater for fuel leaks. Turn fuel shut off valve counterclockwise to open for operation.</li> <li>● Set thermostat above ambient temperature, switch heater reset button to the ON position and heater selector switch to the HEAT position. The thermostat should control the heater automatically, shutting down at the temperature selected.</li> </ul> <p style="text-align: center;">NOTE</p> <p>The blower will continue to run after heater shut down to cool off the combustion chamber. When the combustion chamber cools, the blower will stop automatically.</p> 	Fuel leak exists or heater overheats and fails to shut down.
14	•	•	•		<p>Electrical Shop Set Components:</p> <ul style="list-style-type: none"> <li>• Check electrical cords for frayed or damaged wiring and broken switches.</li> <li>• Test equipment for operation. Check for unusual noises, functional controls, and smooth operation.</li> <li>• Examine condition of attachments and ensure all cutting bits maintain a sharp cutting edge.</li> </ul>	

Page 4-20. Delete old table 4-1 and substitute new table 4-1 as follows:

Table 4-1. Unit Preventive Maintenance Checks and Services

Item No.	Interval	Item to be Checked or Serviced	Procedure	Not Fully Mission Capable if:
1	Monthly or 125 hours	Radiator	Access from top of power unit enclosure and ensure that coolant level is to the top of the filler neck and cold mark on expansion tank. Fill radiator with coolant as necessary.	Coolant is low and/or radiator is leaking.
2	Monthly or 125 hours	Engine Fan V-Belts	Check for proper fan belt tension and condition.	Belts are cracked, broken, missing, or slipping on pulleys.
3	Monthly or 125 hours	Batteries	Remove any corrosion from terminals and/or terminal posts . Inspect for cracks and leaks. Tighten loose cables and terminals. Inspect cells and, if needed, fill with distilled water to 3/8 inch above plates.	
4	Weekly or 50 hours	Engine Oil Level	Check engine oil using dipstick and add oil as needed.	Oil is more than 1 quart low.
5	Quarterly or 100 hours	Engine Oil and Filter	Change engine oil and filter.	
6	Monthly or 125 hours	Circuit Breakers	Inspect for broken or burned circuit breaker, discolored or melted plastic, and proper functioning of circuit breaker.	Circuit breakers are defective.

Table 4-1. Unit Preventive Maintenance Checks and Services - (Cont'd)

Item No.	Interval	Item to be Checked or Serviced	Procedure	Not Fully Mission Capable if:
7	Monthly or 125 hours	Air Compressor	Clean dirt from inter-cooler fins. Check for cracked, broken, or missing belts. Check belt tension and adjust as required.	Belts are cracked, broken, missing, or slipping on pulleys.
8	Monthly or 125 hours	Air Tank	Drain water by turning needle valve clockwise to open, counterclockwise to close. Tighten any mountings and/or connections that have worked loose.	
9	Monthly or 125 hours	Air Compressor System	With air compressor operating check for normal gage reading of 125-150 psi. Check relief valve.	Normal air pressure is not maintained.
10	Monthly or 125 hours	Shop Set Components	Check for proper operation of all power tools. Refer to manufacturer's manuals (appx. A) for further information.	
11	Monthly or 125 hours	Lights and Lenses	Replace burned out lamps and cracked or broken lenses.	
12	Weekly or 50 hours	Airbrake System	Drain water from air brake tank by turning the needle valve clockwise. Close needle valve by turning counterclockwise.	Air brake system is not fully functional.
13	Weekly or 50 hours	Tires and Wheels	Check for cuts and/or bulges in tires. Check that there is 1/16-inch or more of tread remaining on tire. Proper pressure is 75 psi.	There are cuts and/or bulges in tire or if there is less than 1/16-inch of tread remaining. Tire pressure is 65 psi or less.



Table 4-1. Unit Preventive Maintenance Checks and Services - (Cont'd)

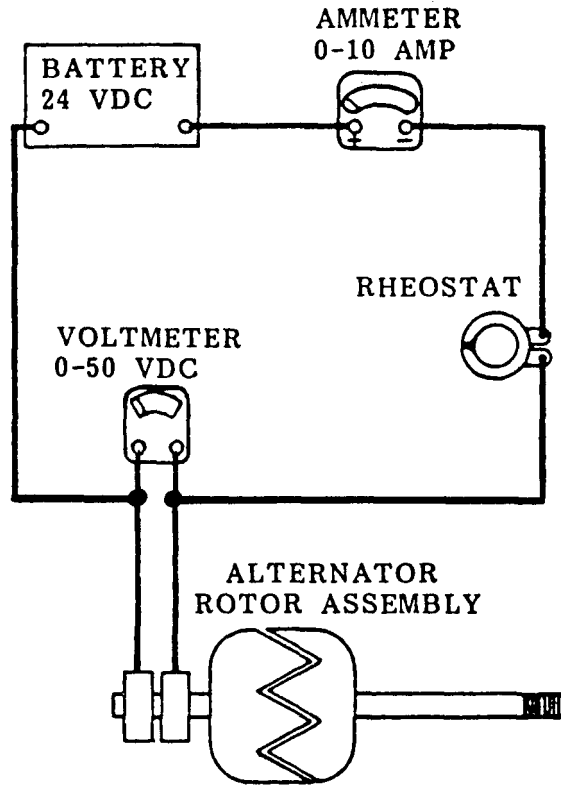
Item No.	Interval	Item to be Checked or Serviced	Procedure	Not Fully Mission Capable if:
14	Quarterly or 400 hours	Fire Extinguisher	Check for unbroken seal and current inspection.	Seal is broken or inspection not current.
15	Monthly or 125 hours	Ground Rod	Check for rust, corrosion, and proper connection. Check wire for breaks.	Ground rod connections are loose or corroded. Wire is broken.
16	Monthly or 125 hours	Brake Linings	Check for brake lining wear.	Less than 1/16-inch of lining left,
17	Quarterly or 300 hours	Engine Fuel Filter	Replace quarterly or after 300 hours of engine operation, whichever comes first.	Fuel filter needs replacement.
18	Monthly or 125 hours	Fuel Tank	Tighten loose mountings or fuel lines. Clean fuel cap vent. Replace fuel tank cap gasket if defective.	Fuel tank is loose or leaking fuel.

Page 6-13. In legend, item 3, "Lens-Amber," change "6220-00-752-5992" to "6220-00-239-7425." In legend, item 3, "Lens-Red," change "6220-00-752-5993" to "6220-00-299-7426."

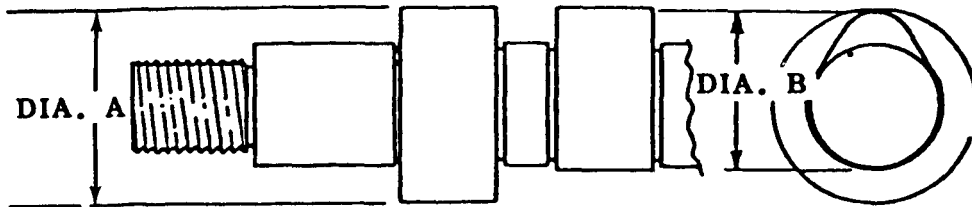
Page 6-24. In legend, item 4, "Lens-Amber," change "6220-00-752-5992" to "6220-00-299-7425." In legend, item 4, "Lens-Red," change "6220-00-752-5993" to "6220-00-299-7426."

Page 6-28. Figure 6-15, item "9" at the center is a receptacle and should be changed to "19."

Page 7-20. Figure 7-7, the hookup for the voltmeter should be changed to appear as follows:



Page 12-24. Figure 12-10, the location of diameter A should be changed to appear as follows:



Page 13-1. In legend, item 3, delete NSN "6125-00-796-8741."

Page 16-1. Paragraph 16-1b, change "TM 5-4520-227-14" to "TM 5-4520-241-14."

Page 19-20. In legend, item 30, change "shoe" to "Brake shoe." Change NSN "2530-00-864-2990" to "2530-00-162-1986." Change PN "7409380" to "11665741."

Page A-1. Paragraph A-1, change "TM 5-4520-227-14" to "TM 5-4520-241-14." Change "operator's Manual for Heater, Space" to "Heater, Space, Multifuel, with Blower, 60,000 BTU/HR." Paragraph A-3, change heading from "SHIPMENT AND STORAGE" to "SAFETY." Delete entry for "TM 740-90-1" and insert "FM 21-11 First Aid for Soldiers."

Page Index 1. Third line, delete entry, "Administrative Storage."

Page Index 2. After ninth line, add entry, "Corrosion Prevention and Control," paragraph "1-7.1," page "1-1."

Page SAMPLE DA Form 2028-2. In "PUBLICATION DATE" block add "12 Mar 84." In "SIGNATURE" block add "Your Signature."



**By Order of the Secretary of the Army:**

**CARL E. VUONO**  
*General, United States Army*  
*Chief of Staff*

**Official:**

**JOHN A. FULMER**  
*Colonel, United States Army*  
*Acting The Adjutant General*

**DISTRIBUTION:**

To be distributed in accordance with DA Form 12-25E, (Block 2744),  
Operator's Unit, Direct and General Support Maintenance Requirements  
for TM 9-4940-549-14&P.

PIN: 054951-001

REPORTING ERRORS AND RECOMMENDING IMPROVEMENTS

You can help improve this manual. If you find any mistakes or if you know of a way to improve the procedures, please let us know. Mail your letter, DA Form 2028 (Recommended Changes to Publications and Blank Forms), or DA Form 2028-2, located in the back of this manual direct to: Commander, US Army Armament, Munitions and Chemical Command, ATTN: DRSMC-MAS, Rock Island, IL 61299. A reply will be furnished directly to you.

Operator, Organizational, Direct Support and General Support Maintenance Manual Including Repair Parts List for:

Shop Equipment, General Purpose  
Repair, Semitrailer Mounted  
Model SGPRSMD  
(NSN 4940-01-006-3229)

NOTE

This manual is published for the purpose of identifying an authorized commercial manual for the use of the personnel to whom this equipment is issued.

Manufactured by: Southwest Truck Body Company  
200 Sidney Street P.O. Box 12245  
St. Louis, MO 63157

Procured under Contract No. DAA09-81-C-2427

\*This manual supersedes TM 9-4940-430-12, 15 February 1982, TM 9-4940-430-34, 22 February 1982, TM 9-4940-430-20P, 20 May 1982, and TM 9-4940-430-34P, 4 May 1982.

## INSTRUCTIONS FOR REQUISITIONING PARTS

## NOT IDENTIFIED BY NSN

When requisitioning parts not identified by National Stock Number, it is mandatory that the following information be furnished the supply officer.

- 1 - Manufacturer's Federal Supply Code Number - 98255.
- 2 - Manufacturer's Part Number exactly as listed herein.
- 3 - Nomenclature exactly as listed herein, including dimensions, if necessary.
- 4 - Manufacturer's Model Number - SGPRSMD
- 5 - Manufacturer's Serial Number (End Item).
- 6 - Any other information such as Type, Frame Number, and Electrical Characteristics, if applicable.
- 7 - If DD Form 1348 is used, fill in all blocks except 4, 5, 6, and Remarks field in accordance with AR 725-50.

Complete Form as Follows:

(a) In blocks 4, 5, 6, list manufacturer's Federal Supply Code Number - 98255 followed by a colon and manufacturer's Part Number for the repair part.

(b) Complete Remarks field as follows:

Noun: (nomenclature or repair part)  
 For: NSN: 4940-01-006-3229  
 Manufacturer: Southwest Truck Body Company  
 200 Sidney St. P.O. Box 12245 St. Louis, MO 63157  
 Model: SGPRSMD  
 Serial: (of end item)

Any other pertinent information such as Frame Number, Type, Dimensions, etc.



TABLE OF CONTENTS

		Para.	Page
CHAPTER 1.	INTRODUCTION		
Section I.	General . . . . .	1-1	1-1
Section II.	Description and Data . . . . .	1-8	1-1
CHAPTER 2.	OPERATING INSTRUCTIONS		
Section I.	Operating Procedures . . . . .	2-1	2-1
Section II.	Operation of Auxiliary Materiel Used In Conjunction With the Shop Set. . . . .	2-6	2-19
Section III.	Operation Under Unusual Conditions . . . . .	2-8	2-19
CHAPTER 3.	OPERATOR/CREW MAINTENANCE INSTRUCTIONS		
Section I.	Lubrication . . . . .	3-1	3-1
Section II.	Preventive Maintenance Checks and Services . . . . .	3-3	3-1
Section III.	Troubleshooting . . . . .	3-5	3-5
Section IV.	Operator/Crew Maintenance . . . . .	3-6	3-12
CHAPTER 4.	GENERAL MAINTENANCE INSTRUCTIONS		
Section I.	Repair Parts, Special Tools, and Equipment . . . . .	4-1	4-1
Section II.	Service Upon Receipt of Material . . . . .	4-4	4-1
Section III.	Movement to a New Work Site . . . . .	4-10	4-18
Section IV.	Lubrication . . . . .	4-12	4-18
Section V.	Preventive Maintenance Checks and Services . . . . .	4-13	4-19
Section VI.	Troubleshooting . . . . .	4-15	4-19
Section VII.	General Maintenance . . . . .	4-17	4-36
Section VIII.	Radio Interference Suppression. . . . .	4-18	4-36
CHAPTER 5.	REMOVAL AND INSTALLATION OF MAJOR COMPONENTS	5-1	5-1
CHAPTER 6	MAINTENANCE OF ELECTRICAL SYSTEMS	6-1	6-1
CHAPTER 7.	ENGINE ELECTRICAL SYSTEM	7-1	7-1
CHAPTER 8.	ENGINE FUEL SYSTEM	8-1	8-1
CHAPTER 9.	ENGINE COOLING SYSTEM	9-1	9-1
CHAPTER 10.	ENGINE LUBRICATION SYSTEM	10-1	10-1
CHAPTER 11.	INTAKE AND EXHAUST SYSTEMS	11-1	11-1
CHAPTER 12.	ENGINE ASSEMBLY	12-1	12-1
CHAPTER 13.	MAINTENANCE OF DYNAMOTOR-WELDER	13-1	13-1
CHAPTER 14.	MAINTENANCE OF THE AIR COMPRESSOR AND RELATED PARTS	14-1	14-1

## TABLE OF CONTENTS-Continued

		Para.	Page
CHAPTER 15.	MAINTENANCE OF BODY COMPONENTS	15-1	15-1
CHAPTER 16.	MAINTENANCE OF PERSONNEL HEATER	16-1	16-1
CHAPTER 17.	MAINTENANCE OF SIDE LIFTING HYDRAULIC SYSTEM	17-1	17-1
CHAPTER 18.	MAINTENANCE OF CONTROL CUBICLE	18-1	18-1
CHAPTER 19.	TRAILER CHASSIS AND COMPONENTS	19-1	19-1
APPENDIX A	REFERENCES		A-1
APPENDIX B	SHOP SET TOOL LOCATION LOADING AND PACKING LIST		B-1
APPENDIX C	EXPENDABLE/CONSUMABLE MAINTENANCE SUPPLIES AND MATERIALS		C-1
	INDEX		Index 1
	FOLDOUT PAGES		

LIST OF ILLUSTRATIONS

<u>Figure</u>	<u>Title</u>	<u>Page</u>
1-1	Shop Set, Doors Closed. . . . .	1-2
1-2	Shop Set, Doors Open. . . . .	1-3
1-3	Shop Set, Tent Installed. . . . .	1-4
2-1	Hydraulic System Controls . . . . .	2-2
2-2	Engine Controls and Instruments . . . . .	2-3
2-3	Air Compressor Drive Motor Control and Air Receiver Tank Pressure Gage . . . . .	2-6
2-4	Electrical System Control Panel . . . . .	2-7
2-5	Overspend Safety Switch . . . . .	2-10
2-6	Starting the Shop Set Engine . . . . .	2-12
2-7	Stopping the Shop Set Engine . . . . .	2-13
2-8	Personnel Heater Controls and Operation . . . . .	2-15
4-1	Shop Set Blocking and Tiedown Instructions . . . . .	4-2
4-2	Flatcar with Ramp in Place . . . . .	4-3
4-3	Batteries, Removal, Installation and Service . . . . .	4-5
4-4	Raising and Lowering Shop Set Side Doors . . . . .	4-7
4-5	Opening Shop Set Rear Doors and Panels . . . . .	4-8
4-6	Laying Out Tent Framing . . . . .	4-3
4-7	Erecting Tent Planning (Sheet 1 of 2) . . . . .	4-10
4-7	Erecting Tent Planning (Sheet 2 of 2) . . . . .	4-11
4-8	Erecting Tenting (Sheet 1 of 3) . . . . .	4-12
4-8	Erecting Tenting (Sheet 2 of 3) . . . . .	4-13
4-8	Erecting Tenting (Sheet 3 of 3) . . . . .	4-14
4-9	External Power Supply, Disconnection and Reconnection. . . . .	4-15
4-10	Grounding the Shop Set . . . . .	4-16
4-11	Voltage and Frequency Conversion . . . . .	4-17
4-12	Interference Suppression Components, Removal and Installation (Sheet 1 of 2) . . . . .	4-38
4-12	Interference Suppression Components, Removal and Installation (Sheet 2 of 2) . . . . .	4-39
5-1	Engine Enclosure, Removal and Installation . . . . .	5-2
5-2	Engine and Dynamotor-Welder, Removal and Installation. . . . .	5-4
5-3	Control Cubicle, Removal and Installation . . . . .	5-6
5-4	Shop Body, Removal and Installation . . . . .	5-8
6-1	110 Volt Electrical Installation (Sheet 1 of 6) . . . . .	6-2
6-1	110 Volt Electrical Installation (Sheet 2 of 6) . . . . .	6-3
6-1	110 Volt Electrical Installation (Sheet 3 of 6) . . . . .	6-4
6-1	110 Volt Electrical Installation (Sheet 4 of 6) . . . . .	6-5
6-1	110 Volt Electrical Installation (Sheet 5 of 6) . . . . .	6-6
6-1	110 Volt Electrical Installation (Sheet 6 of 6) . . . . .	6-7
6-2	24 Volt DC Electrical Installation (Sheet 1 of 2) . . . . .	6-10
6-2	24 Volt DC Electrical Installation (Sheet 2 of 2) . . . . .	6-11
6-13	Service and Blackout Clearance Lights, Removal and Installation. . . . .	6-13
6-4	Convenience Receptacles, Lamp Bases, and Toggle Switches . . . . .	6-15

LIST OF ILLUSTRATIONS  
Continued

<u>Figure</u>	<u>Title</u>	<u>Page</u>
6-5	Floodlights, Removal and Installation . . . . .	6-16
6-6	Lamp Replacement . . . . .	6-17
6-7	Light Assembly, Removal and Installation . . . . .	6-17
6-8	Front Ventilator, Removal and Installation . . . . .	6-18
6-9	Rear Ventilator Fan Assembly, Removal and Installation . . . . .	6-19
6-10	Rear Ventilators, Disassembly and Removal . . . . .	6-20
6-11	Emergency and External Power Receptacle, Removal and Installation . . . . .	6-21
6-12	Clearance Lights, Removal and Installation . . . . .	6-24
6-13	Composite Light Assembly, Disassembly and Assembly. . . . .	6-25
6-14	Junction Box, Removal and Installation . . . . .	6-26
6-15	Rear Wiring to Floodlight, Removal and Installation. . . . .	6-28
7-1	Batteries and Battery Box, Removal and Installation. . . . .	7-2
7-2	Starter Assembly, Removal and Installation . . . . .	7-4
7-3	Starter, Disassembly and Assembly . . . . .	7-6
7-4	Starter Assembly Motoring Test Circuit . . . . .	7-12
7-5	Alternator, Removal and Installation . . . . .	7-14
7-6	Alternator, Disassembly and Assembly . . . . .	7-17
7-7	Rotor Assembly Current Draw Test Circuit . . . . .	7-20
7-9	Alternator Positive Output Circuit Test . . . . .	7-23
7-10	Total Circuit Voltage Test . . . . .	7-24
7-11	Excitation Voltage Tests . . . . .	7-25
7-13	Faulty Voltage Regulator Circuit Test . . . . .	7-26
7-14	Field Current Test . . . . .	7-28
7-15	Output and Voltage Protection Test . . . . .	7-28
7-16	Coolant Thermostat and Sensors, Removal and Installation . . . . .	7-30
7-17	Oil Sending Units, Removal and Installation . . . . .	7-31
8-1	Fuel Tank, Lines, and Fittings, Removal and Installation . . . . .	8-2
8-2	Fuel Transfer Dump, Removal and Installation . . . . .	8-4
8-3	Primary Fuel Filter, Removal and Installation . . . . .	8-6
8-4	Secondary Fuel Filter, Removal and Installation . . . . .	8-8
8-5	Fuel Injection Pump, Removal and Installation . . . . .	8-10
8-6	Fuel Injection Pump Governor . . . . .	8-13
8-7	Fuel Injection Pump Linkage and Control . . . . .	8-15
8-8	Fuel Injection Pump End Plates and Blades . . . . .	8-17
8-9	Fuel Injection Pump, Pivot Shaft and Arm Assembly. . . . .	8-18
8-10	Fuel Injection Pump Piston and Damper Spring . . . . .	8-19
8-11	Fuel Injection Pump Rotor Assembly . . . . .	8-20
8-12	Fuel Injection Pump Housing and Drive Shafts . . . . .	8-22
8-13	Adjusting Fuel Injection Pump Roller-to-Roller Dimension . . . . .	8-28
8-14	Fuel Injection Lines and Fittings . . . . .	8-38

LIST OF ILLUSTRATIONS  
Continued

<u>Figure</u>	<u>Title</u>	<u>Page</u>
8-15	Fuel Nozzle and Holder . . . . .	8-40
8-16	Quick Start System. . . . .	8-43
9-1	Radiator and Support Rods . . . . .	9-2
9-2	Front Support and Tire Rod . . . . .	9-4
9-3	Fan and Water Pump Assembly . . . . .	9-8
9-4	Checking Impeller to Cover Plate Clearance . . . . .	9-11
10-1	Oil Filter and Hose Assembly . . . . .	10-2
10-2	Oil Pan . . . . .	10-5
10-3	Oil Pump Assembly . . . . .	10-7
10-4	Oil Pump Assembly Dimension . . . . .	10-9
11-1	Air Cleaner and Tube. . . . .	11-2
11-2	Muffler and Cap . . . . .	11-5
11-3	Intake and Exhaust Manifolds . . . . .	11-7
12-1	Flywheel and Housing. . . . .	12-3
12-2	Checking Flywheel Concentricity and Alignment . . . . .	12-5
12-3	Gear Housing and Covers . . . . .	12-7
12-4	Cylinder Head and Valve Mechanism . . . . .	12-11
12-5	Rocker Arm Mounting Blocks Installation . . . . .	12-17
12-6	Rocker Arm Shaft Positioning . . . . .	12-18
12-7	Cylinder Head Nut Tightening Sequence . . . . .	12-19
12-8	Valve Tappet Clearance Adjustment . . . . .	12-21
12-9	Camshaft, Exploded View . . . . .	12-22
12-10	Dimensional Inspection of Camshaft . . . . .	12-24
12-11	Piston and Connecting Rods . . . . .	12-27
12-12	Cylinder Block Assembly (Sheet 1 of 2) . . . . .	12-28
12-12	Cylinder Block Assembly (Sheet 2 of 2) . . . . .	12-29
12-13	Clutch and Cover. . . . .	12-40
12-14	Clutch Assembly, Removal, Disassembly, Reassembly and Installation . . . . .	12-43
13-1	Ventilating Air Filters, Removal and Installation. . . . .	13-1
13-2	Dynamotor-Welder End Wrappers, Removal and Installation. . . . .	13-2
13-3	Dynamotor-Welder Brush Replacement and Tension Adjustment. . . . .	13-4
13-4	Overspeed Safety Switch Adjustment . . . . .	13-6
13-5	Overspeed Safety Switch, Exploded View . . . . .	13-7
13-6	End Cover and Bearing Cap, Removal and Installation. . . . .	13-11
13-7	Dynamotor-Welder Armature, Removal and Installation. . . . .	13-12
13-8	Dynamotor-Welder Armature, Disassembly and Assembly. . . . .	13-13
13-9	Dynamotor-Welder Frames, Field Coils, Pole Shoes, Brush Holders and Mounting Rings, Exploded View (Sheet 1 of 3) . . . . .	13-14
13-9	Dynamotor-Welder Frames, Field Coils, Pole Shoes, Brush Holders and Mounting Rings, Exploded View (Sheet 2 of 3) . . . . .	13-16

LIST OF ILLUSTRATIONS  
Continued

<u>Figure</u>	<u>Title</u>	<u>Page</u>
13-9	Dynamotor-Welder Frames, Field Coils, Pole Shoes, Brush Holders and Mounting Rings, Exploded View (Sheet 3 of 3) . . . . .	13-18
13-10	Terminal Board, Removal and Installation . . . . .	13-20
13-11	Motor Terminal Board, Removal and Installation . . . . .	13-21
14-1	Air Compressor and Drive Motor Assembly, Removal and Installation . . . . .	14-2
14-2	Inlet Filter, Exploded View . . . . .	14-4
14-3	Air Receiver Tank Pop-Off Valve . . . . .	14-4
14-4	Compressor Starter Control Box, Exploded View . . . . .	14-5
14-5	Pressure Switch . . . . .	14-6
14-6	Frame End Cover, Exploded View . . . . .	14-7
14-7	Fanwheel Aftercooler and Intercooler, Exploded View . . . . .	14-8
14-8	Low Pressure Cylinder Piston, Rod, and Rings, Exploded View . . . . .	14-10
14-9	High Pressure Cylinder, Piston, Rod, and Rings, Exploded View . . . . .	14-12
14-10	Crankshaft Assembly, Exploded View . . . . .	14-14
14-11	Belt Guard Assembly, Removal and Installation . . . . .	14-20
14-12	Belt Tightener and Base Assembly, Removal and Installation. . . . .	14-21
15-1	Side Doors, Removal and Installation . . . . .	15-1
15-2	Rear Door and Panel, Removal and Installation . . . . .	15-2
15-3	Tent Frame, Removal and Installation . . . . .	15-4
15-4	Grinder, Removal and Installation . . . . .	15-5
15-5	Milling and Grinding Attachment, Removal and Installation . . . . .	15-6
15-6	Valve Refacer, Removal and Installation . . . . .	15-7
15-7	17 1/2-Ton Press Frame, Removal and Installation . . . . .	15-8
15-9	Vise, Removal and Installation . . . . .	15-9
15-10	Lathe Belt, Removal and Installation . . . . .	15-10
15-11	Lathe, Removal and Installation . . . . .	15-11
15-12	Lathe Stand, Removal and Installation . . . . .	15-12
15-13	Hinged Table, Removal and Installation . . . . .	15-13
15-14	Cabinet Assembly, Removal and Installation . . . . .	15-14
15-15	Track and Trolley Assembly, Removal and Installation. . . . .	15-15
15-16	Miscellaneous Van Body Components, Removal and Installation. . . . .	15-16
16-1	Personnel Heater, Removal and Installation . . . . .	16-1
16-2	Tent Curtains . . . . .	16-3
17-1	Hydraulic Pump, Removal and Installation . . . . .	17-2
17-2	Side Lifting Cylinder and Hydraulic Hose, Removal and Installation . . . . .	17-4
17-3	Side Lifting Cylinder, Exploded View . . . . .	17-6
17-4	Hydraulic Pump, Exploded View . . . . .	17-7
18-1	Rotary Switch (10-Range), Exploded View . . . . .	18-1

LIST OF ILLUSTRATIONS  
Continued

<u>Figure</u>	<u>Title</u>	<u>Page</u>
18-2	Cubicle Control Components, Removal and Installation. . . . .	18-3
18-3	Generator Output Contactor, Exploded View . . . . .	18-4
18-4	Overload Switch, Exploded View . . . . .	18-6
18-5	Resistor and Relay Mounting Panel, and Emergency Power Panel . . . . .	18-8
18-6	Dynamotor-Welder Control Panel . . . . .	18-11
18-7	Upper Control Panel . . . . .	18-16
18-8	Lower Control Panel . . . . .	18-18
18-9	Control Box and Coil Assembly, Removal and Installation. . . . .	18-19
18-10	Engine Control Panel, Right Hand . . . . .	18-21
18-11	Engine Control Panel, Left Hand . . . . .	18-23
19-1	Tire and Rim. . . . .	19-2
19-2	Hub and Drum. . . . .	19-5
19-3	Brake Adjustment. . . . .	19-8
19-4	Air Reservoir and Relay Valve . . . . .	19-10
19-5	Front Air Brake Lines and Air Filter . . . . .	19-12
19-6	Rear Air Brake Lines . . . . .	19-14
19-7	Brake Air Chamber and Master Cylinder . . . . .	19-16
19-8	Brake Shield and Shoe . . . . .	19-19
19-9	Axle Assembly . . . . .	19-22
19-10	Pivot Axle. . . . .	19-25
19-11	Landing Gear, Removal and Installation . . . . .	19-28
19-12	Landing Gear. . . . .	19-29
19-13	Compartment Panels and Access Doors . . . . .	19-32
19-14	Compartment Doors . . . . .	19-34
19-15	Compartment Panel and Brackets and Seal Assembly . . . . .	19-36
19-16	Frame and Brackets. . . . .	19-38
19-17	Towing Pintle. . . . .	19-40
19-18	Front Ladder. . . . .	19-42
19-19	Frame and Wiring. . . . .	19-44
B-1	Shop Set Location . . . . .	B-1





## CHAPTER 1

## INTRODUCTION

---

Section I. GENERAL

## 1-1. SCOPE .

a. This manual is published for the use of the personnel to whom the Truck Body Model SGPRSD, Semitrailer Mounted General Purpose is issued.

b. This manual provides information related to the contents of the shop set and includes wiring diagrams (Figures FO-1 through FO-4). For operating and maintenance instructions pertaining to the truck and components other than the shop equipment contents covered in this publication, refer to Appendix A, Reference.

1-2. MAINTENANCE FORMS AND RECORDS. Equipment maintenance forms and records and procedures for their use are contained in DA PAM 738-750 as contained in Maintenance Management Update.

1-3. ADMINISTRATIVE STORAGE. For information necessary to meet Administrative Storage Requirements, refer to TM 740-90-1.

1-4. EQUIPMENT SERVICEABILITY CRITERIA (ESC). There are no Equipment Serviceability Criteria (ESC) technical manuals in existence pertinent to the end item of equipment being covered in this publication.

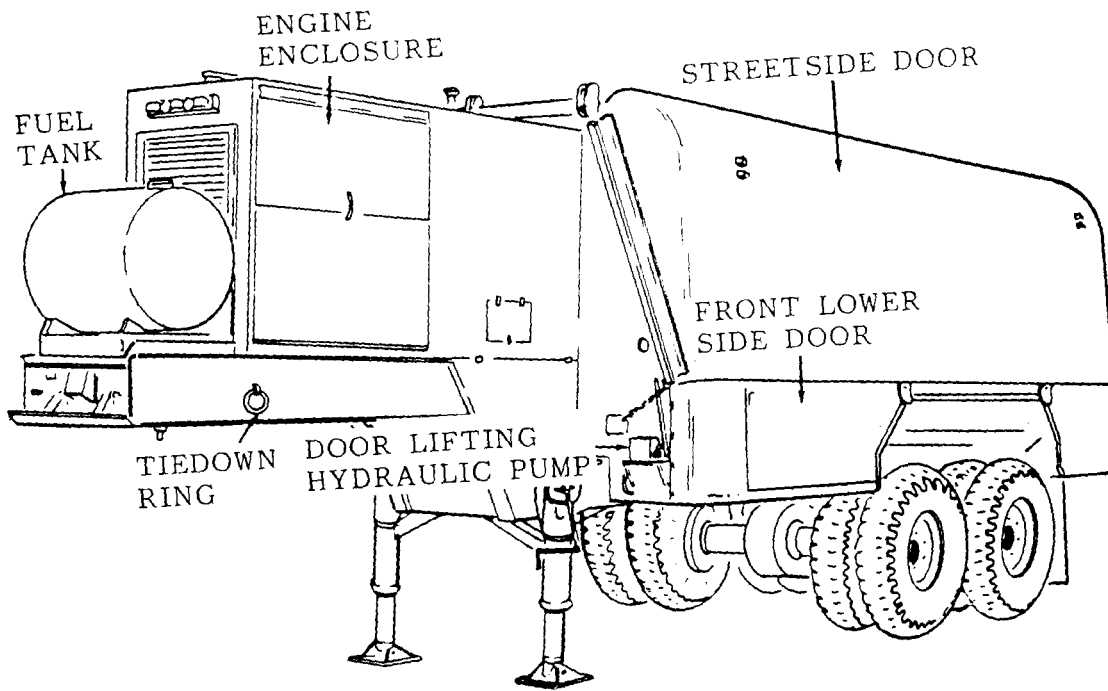
1-5. DESTRUCTION OF ARMY MATERIEL TO PREVENT ENEMY USE. For procedures required to render this end item unusable by the enemy, refer to TM 750-244-3.

1-6. QUALITY ASSURANCE/QUALITY CONTROL (QA/QC). There is no Quality Assurance/Quality Control (QA/QC) manual in existence containing the applicable requirements for maintenance of the equipment covered in this publication.

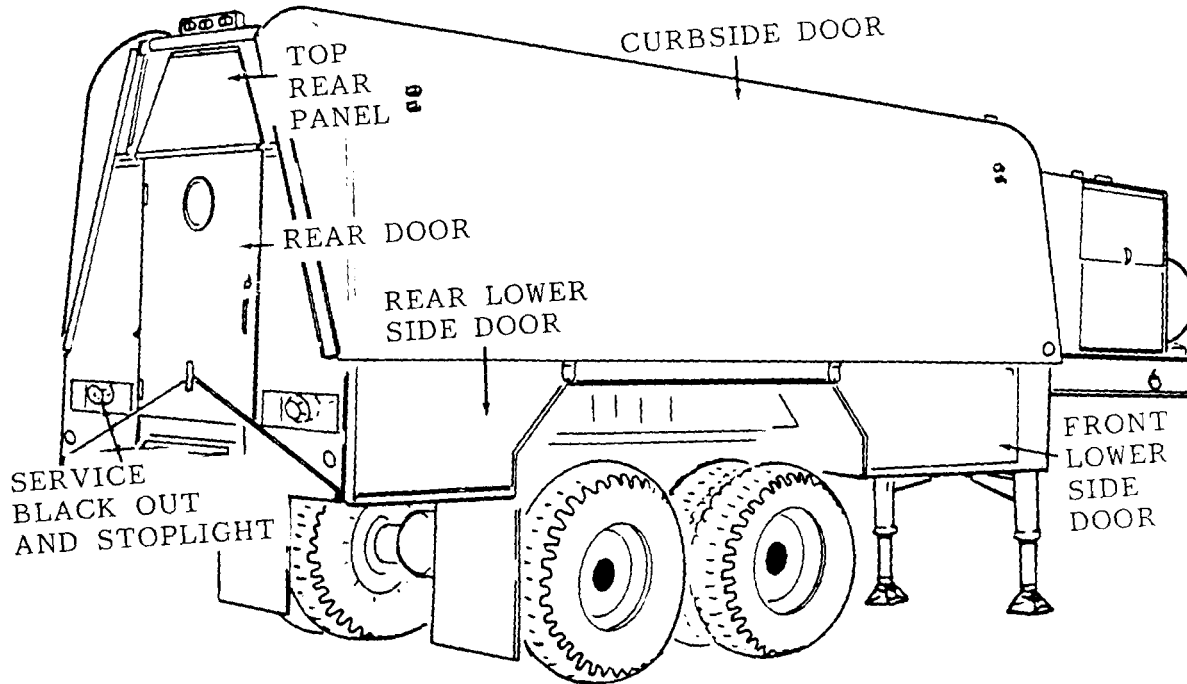
1-7. REPORTING QUALITY DEFICIENCY REPORTS (QDR). QDR's will be prepared on SF 368, Quality Deficiency Report. Instructions for preparing QDR's are provided in DA PAM 738-750 as contained in Maintenance Management Update. QDR's should be mailed directly to Commander, US Army Armament, Munitions and Chemical Command, ATTN: DRSMC-MAO, Rock Island, IL 61299. A reply will be furnished directly to you.

## Section II. DESCRIPTION AND DATA

1-8. DESCRIPTION. The Model SGPRSD Shop Set (fig. 1-1) is semi-trailer mounted and contains tools and equipment that are used for maintenance and repair of mechanical equipment. The trailer is equipped with doors to provide easy access to the equipment in the set (fig. 1-2). A weather protected work area may be set up around the trailer (fig. 1-3). A

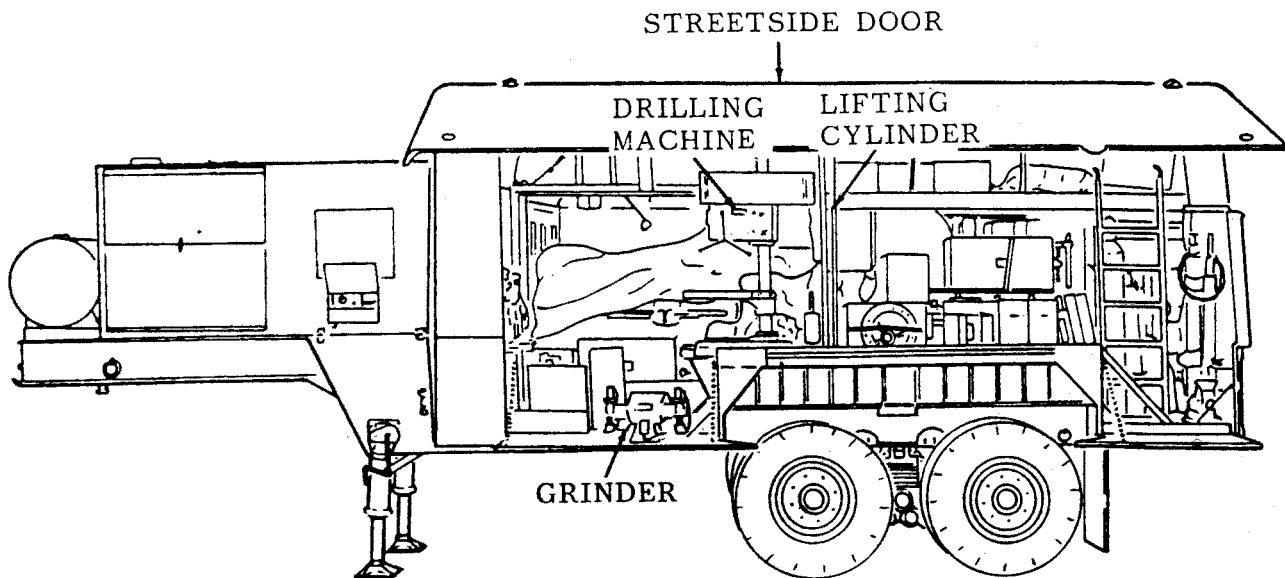


A. LEFT FRONT 3/4 VIEW.

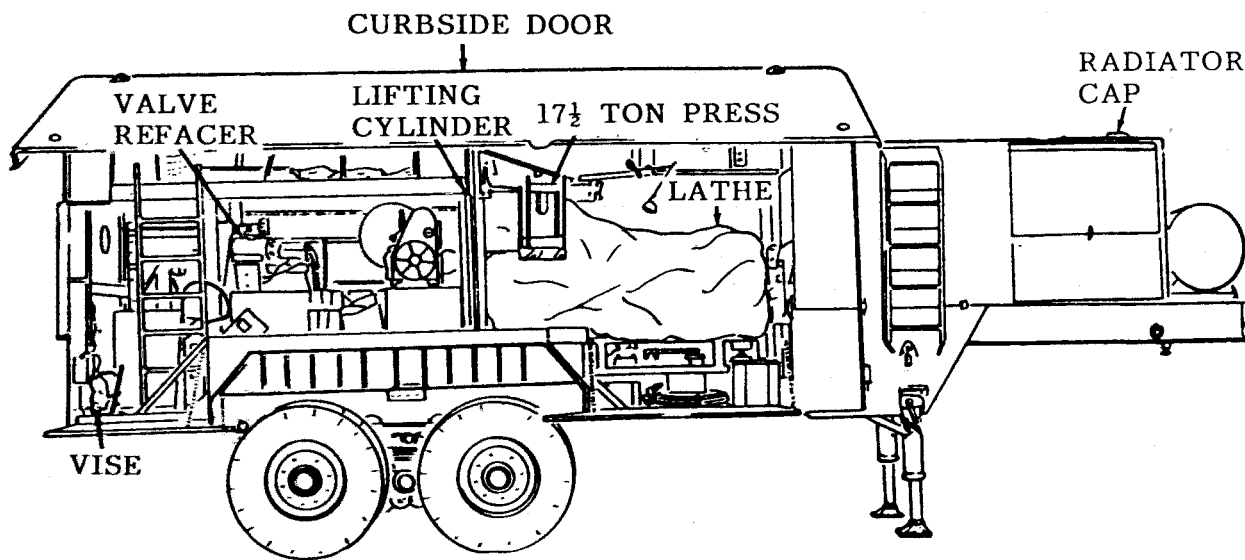


B. RIGHT REAR 3/4 VIEW.

Figure 1-1. Shop Set, Doors Closed.



A. LEFT SIDE VIEW.



B. RIGHT SIDE VIEW.

Figure 1-2. Shop Set, Doors Open.

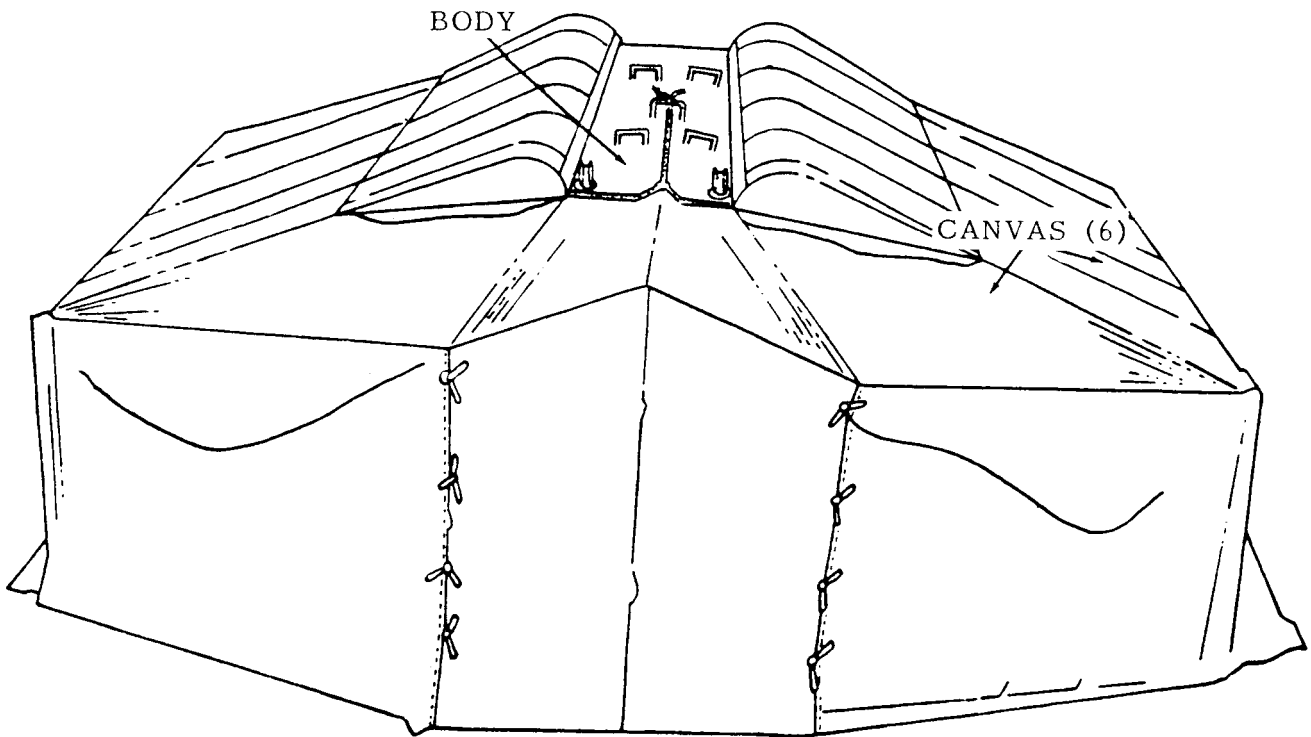


Figure 1-3. Shop Set, Tent Installed.

dynamotor-welder is included that may be driven by the shop set engine or by a 240-volt AC external power source. When driven by the engine, the dynamotor-welder provides direct current for welding , a-rid alternating current for the power 'tools and equipment. When driveMNby an external power source, the dynamotor-welder acts as a synchronous motor to provide direct current for welding . The external power source is used to operate the shop set's power tools and equipment. A personnel heater is provided for cold weather operation. The term "Shop Set" as used in this document is synonymous with the title " Shop Equipment" .

**1-9. DATA.**

a. Identification. The major components of the shop set are equipped with plates which identify the components and provide limited tabulated data. The major identification plates on the shop set are as follows:

- (1) The U.S. Army Identification Plate. Located on the curbside, forward of the side door of the trailer.
- (2) The Engine Identification Plate.
- (3) The Dynamotor-Welder Plate.
- (4) The Personnel Heater U.S. Army Identification Plate.
- (5) The Air Compressor Identification Plate.

b. Tabulated Data.

(1) Shop Set.

Model Number.....	SGPRSMD
Serial Number Range.....	S-11-204 thru S-11-368
Nomenclature . . . . .	Shop Equipment, General Purpose Repair, Semi-Trailer Mounted
Gross vehicle weight.....	31,000 lbs.
Length.....	351.5 in.
Height.....	125.5 in.
Width.....	97 in.
Cube.....	2476 ft.
Ship Wt.....	30,150 lbs.

(2) Engine Data.

No. of cylinders.....	6
Type . . . . .	4 cycle, overhead valve, diesel
Firing order.....	1-5-3 -6-2-4
Oil pressure . . . . .	40-60 psi
Model.....	D298ERX48
Bore.....	3 3/4 in.
Stroke.....	4 1/2 in.
Displacement.....	298 cu. in.

Number of bearings . . . . .	5
Bearing diameter . . . . .	2-7/8 inches
Bearing lengths:	
Front . . . . .	1-1/32 inches
Center . . . . .	2-1/8 inches
Rear . . . . .	1-1/32 inches
Intermediate . . . . .	1-1/32 inches
Connecting rod:	
Bearing diameter . . . . .	2-3/8 inches
Bearing length . . . . .	1-11/64 inches
Rod length . . . . .	8 inches
Piston and piston pin:	
Piston material . . . . .	Heat treated aluminum alloy
Pin material . . . . .	Alloy steel
Tin type . . . . .	Full floating
Camshaft:	
Number of bearings . . . . .	4
Bearing diameter . . . . .	2-1/16 inches
Bearing lengths:	
Front . . . . .	1-1/16 inches
Intermediate . . . . .	13/16 inch
Rear . . . . .	1-1/16 inches
Cylinder head:	
Material . . . . .	Alloy casting
Valve arrangement . . . . .	Overhead

Fuel injection pump.

Model . . . . .	DBGFC633X1HB
-----------------	--------------

Nut and bolt torque data.

Engine:	
Cylinder head nuts:	
9/16 dia. studs . . . . .	160 lb-ft.
5/8 dia. studs . . . . .	175 lb-ft.
Nozzle holder	
attaching screw . . . . .	23 lb-ft.
Connecting rod bolt . . . . .	70 lb-ft.
Main bearing cap:	
9/16 in . . . . .	130 lb-ft.
1/2 in . . . . .	100 lb-ft.
Camshaft gear nut . . . . .	130 lb-ft.
Flywheel bolts . . . . .	80 lb-ft.
Manifold attaching nut . . . . .	18-20 lb-ft.
Fuel pump gear nut . . . . .	60-65 lb-ft.
Crankshaft pulley nut . . . . .	125 lb-ft.
Bellhousing screw . . . . .	75 lb-ft.
Idler shaft screw . . . . .	24-27 lb-ft.
Fuel injection pump:	
Mounting screw . . . . .	30-40 lb-ft.
End plate . . . . .	30 in-lb.
Body plugs (side) . . . . .	215-265 in-lb.

Body plug (bottom) . . . . .	40-50 in-lb.
Connector screw . . . . .	420 in-lb.
Cam advance screw . . . . .	400 in-lb.
Cap and filter assy.....	240 in-lb.
Guide stud . . . . .	115 in-lb.
Cover holddown screw.. . . .	40 in-lb.
Shutoff lever	
retaining screw. . . . .	30 in-lb.
Pivot shaft	
retainer nut.....	25 in-lb.
Torque screw nut.....	25 in-lb.
Timing line cover	
screw.....	20 in-lb.
Head locating screw . . . . .	20 in-lb.
Head locking screws.....	175 in-lb.
Cam locking screw.....	500 in-lb.
End plate plug.....	60 in-lb.
End plate pipe plug . . . . .	360 in-lb.
Fuel pump	
drive gear nut.....	35-40 in-lb.

(3) Dynamotor-welder.

Specifications . . . . .	5765-1
Model.....	SMD 300

D.C. Generator:

volts.....	32
Amperes . . . . .	300
RPM.....	1,800
Duty cycle . . . . .	60%

A.C. Generator:

volts.....	240
Amperes . . . . .	50
K W.....	12
P.F. (Power Factor).....	0.8
Phase.....	3
Hertz.....	60
RPM.....	1,800
Duty cycle.....	100%

Motor:

volts.....	240
Amperes . . . . .	50
Phase . . . . .	3
Hertz.....	50/60
RPM.....	1,500/1,800
HP . . . . .	20/25

(4) Personnel heater.

Nomenclature . . . . .	Heater, Space, Multifuel, 60,000 BTU
NSN . . . . .	4520-00-999-8523
Model . . . . .	UH-68-4
Length . . . . .	28-318 in.
Width . . . . .	11-1/16 in.
Height . . . . .	21-3/16 in.
Shipping weight . . . . .	120 lbs.
Cube . . . . .	3.85 CU. ft.

(5) Air compressor.

Type . . . . .	2 Stage, single acting
Model . . . . .	2342
Revolutions per minute. . . . .	610 rpm
Bore:	
First Stage . . . . .	3 in.
Second Stage . . . . .	1-3/4 in.
Stroke . . . . .	3 in.
Intercooler. . . . .	Tube, air cooled
Aftercooler . . . . .	Tube, air cooled
Receiver size . . . . .	40 gal.
Model . . . . .	145TTDR8350AA, frame 145
Type . . . . .	Constant speed, ball bearing, horizontal, drip proof
Voltage . . . . .	230/460 Vac
Rating/speed. . . . .	2 hp/1,735 rpm
Phase/hertz . . . . .	Three/60

(6) Capacities.

Engine:

Crankcase . . . . .	7 quarts (add 1 qt. for oil filter)
Oil filter . . . . .	1 quart
Air cleaner . . . . .	2.8 pts. approx.
Fuel tank . . . . .	55 gallons
Cooling system . . . . .	24 quarts,

Air compressor:

Crankcase . . . . .	4 pints.
---------------------	----------



Hydraulic system:

Door lifter..... 2-1/2 quarts (2 reservoirs)

(7) Adjustment data.

Engine fan belts..... 1/2-inch deflection midway  
between generator drive pulley  
and crankshaft pulley

Compressor drive belts . . . . . 1/2-inch deflection midway  
between motor drive pulley  
and compressor pulley

Lathe drive belts..... 1/2-inch deflection midway  
between motor drive pulley  
and lathe pulley

(8) Fits and tolerances (engine). Refer to table 1-1 for engine fits  
and tolerances.

(9) Air compressor torque and tolerances. Refer to tables 1-2 and  
1-3 for torque values and manufacturer tolerances.

(10) Wiring diagrams. Refer to figures FO-1, FO-2, FO-3, and FO-4  
for wiring diagrams.

Table 1-1. Fits and Tolerances (Engine)

Component	Tolerances		Desired Clearance		Maximum Allowable Wear	Maximum Allowable Clearance
	Minimum	Maximum	Minimum	Maximum		
CYLINDER BLOCK:						
Cylinder bore dia.	3.7490	3.7510			0.0050	
Cylinder bore out of round		0.0005			0.0030	
Cylinder bore taper		0.0005			0.0020	
Main brg. bore-less brgs.	3.0665	3.0670				
Camshaft brg. bore-less brgs.	2.1870	2.1880				
Oil pump bore	2.0000	2.0005				
Valve tappet bore	0.7494	0.7500				
Warpage		0.0003				
Milling		0.0005				
CRANKSHAFT:						
Main brg. journal dia.	2.8734	2.8744			0.0030	
Main brg. journal out of round		0.0003			0.0030	
Main brg. journal taper		0.0003			0.0015	
Main brg. run-out at center		0.0020			0.0030	
Conn. rod journal dia.	2.3730	2.3640			0.0020	
Conn. rod journal out of round		0.0003			0.0020	
Conn. rod journal taper		0.0003			0.0015	
Fillet radii	0.1400	0.1700				
Crank main brg. clearance			0.0009	0.0034		0.0070
Crankshaft thrust clearance			0.0050	0.0100		0.0150
Seal surface dia. - rear	4.3100	4.3150			0.0150	
Seal surface dia. - front	1.8740	1.8760			0.0150	
CONNECTING ROD:						
Length - c to c	7.9980	8.0020				
Brg. bore-less brgs.	2.5260	2.5270				
Br. to crank clearance			0.0010	0.0030		0.0050

Table 1-1. Fits and Tolerances (Engine) - Continued

Component	Tolerances		Desired Clearance		Maximum Allowable Wear	Maximum Allowable Clearance
	Minimum	Maximum	Minimum	Maximum		
Conn. rod side clearance			0.0050	0.0120		0.0200
Piston pin cushioning bore-less bushing	1.4370	1.4380				
Piston pin bushing bore	1.2503	1.2508			0.0015	
CAMSHAFT:						
Bearing journal dia. 2.0530	2.0540				0.0020	
Lobe dia. - base to tip	1.7200	1.7250			0.0100	
Journal run-out in vee blocks		0.0010			0.0040	
Bearing clearance			0.0015	0.0035		0.0060
End thrust			0.0015	0.0055		0.0120
Backlash - cam to crank gear			0.001	0.003		
PISTON:						
Clearance in cyl. bore (pull on 1/2 X 0.0050 ribbon)	5 lb.	8 lb.				
Piston pin bore	1.2500	1.2502			0.0010	
Width of ring groove - top - Keystone	1/8	nom.				
Width of ring groove - 2nd & 3rd comp.	0.0975	0.0990			0.0050	
Width of ring groove - top oil control	0.1880				0.0050	
Width of ring groove - lower oil control	0.1880	0.1890			0.0050	
PISTON PIN:						
Length	3.0350	3.0400				
Diameter	1.2498	1.2499			0.0020	
Clearance in piston			0.0000	0.0005		0.0020
Clearance in conn. rod			0.0005	0.0012		0.0050
PISTON RING:						
Clearance in groove - top	Keystone	Taper				
Clearance in groove - 2nd & 3rd comp.	0.0040	0.0060				0.0080
Clearance in groove - oil control	0.0015	0.0030				0.0080
Gap	0.0100	0.0200				0.0400

Table 1-1. Fits and Tolerances (Engine) - Continued

Component	Tolerances		Desired Clearance		Maximum Allowable Wear	Maximum Allowable Clearance
	Minimum	Maximum	Minimum	Maximum		
VALVE INTAKE:						
Head diameter	1.6825	1.6825				
Stem diameter	0.3725	0.3735			0.0025	
Stem to guide clearance			0.0005	0.0025		0.0050
Stem to rocker arm clearance - hot			0.0150			
Seat diameter in head	1.6470	1.6530			1/8	
Seat width in head		7/64				
Top of valve recessed below cyl. hd. deck	0.0210					
Valve seat angle	30°					
VALVE EXHAUST:						
Head diameter	1.4950	1.5050				
Stem diameter	0.3740	0.3750			0.0025	
Stem to guide clearance			0.0015	0.0035		0.0060
Stem to rocker arm clearance - hot			0.0150			
Seat diameter in head	1.4510	1.4560			1/8	
Seat width in head		7/64				
Top of valve recessed below cyl. hd. deck	0.0210					
Valve seat angle	45°					
VALVE GUIDE:						
Length	2.7243	2.7444				
Outside diameter	0.6265	0.6270				
Bore dia. - intake - ream	0.3740	0.3750			0.0030	
Bore dia. - exhaust - ream	0.3750	0.3760			0.0030	
Depth below cyl. hd. deck	1.3700	1.3800				
TAPPET, VALVE LIFTER (PUSH ROD):						
Body diameter	0.7485	0.7490			0.0030	
Overall length	2.2450	2.2550				
Clearance in bore (block)			0.0005	0.0015		0.0050

Table 1-1. Fits and Tolerances (Engine) - Continued

Component	Tolerances		Desired Clearance		Maximum Allowable Wear	Maximum Allowable Clearance
	Minimum	Maximum	Minimum	Maximum		
VALVE SPRINGS -						
INTAKE & EXHAUST:						
Free length	1.7960	1.8360				
Total coils	6-1/4					
Diameter wire	0.1770					
Outside diameter	1.2920	1.3020				
Test load at 1.4920 inches (lbs.)	72	82				
Test load at 1.0820 inches	163	180				
OIL PUMP BODY:						
Shaft bore diameter - main	0.6255	0.6265			0.0030	
Shaft bore diameter - idler	0.6255	0.6265			0.0030	
Pump gear bore diameter	1.5005	1.5015			0.0050	
Pump gear bore depth	1.5640	1.5650			0.0040	
Mounting flange & top of drive flange			4.83375	4.85373	0.010	
SHAFTS:						
Length - main	9.2400	9.2500				
Length - idler	2.7450	2.7550				
Diameter - main	0.6240	0.6245			0.0020	
Diameter - idler	0.6240	0.6245			0.0020	
Shaft clearance in body			0.0010	0.0025	0.0030	0.0060
GEARS:						
Outside diameter - both	1.4975	1.4985			0.0020	
Length - both	1.5610	1.5620				
Clearance in body bore			0.0020	0.0040		0.0070
End clearance to body			0.0020	0.0040		0.0080
Backlash, drive gear to cam			0.0060	0.0120		0.0200
FLYWHEEL:						
Clutch face run out at 6" rad.		0.0080				
Pilot bore eccentricity		0.0050				

Table 1-1. Fits and Tolerances (Engine) - Continued

Component	Tolerances		Desired Clearance		Maximum Allowable Wear	Maximum Allowable Clearance
	Minimum	Maximum	Minimum	Maximum		
ROCKER ARM MECHANISM:						
Rocker shaft length - 6 cyl.	13.7400	13.7600				
Rocker shaft diameter	0.8590	0.8600			0.0030	
Rocker arm bore diameter	0.8625	0.8635			0.0030	
Rocker arm clearance on shaft			0.0025	0.0045		0.0120
Tappet adj. screw torque	3 lbs.ft.	10 lbs.ft.				
FUEL PUMP:						
Throttle shaft and linkage hook	0.210	0.225	0.217			
Impeller to cover plate			0.010			
CYLINDER HEAD:						
Warpage (longitudinally)					0.005	
Warpage (laterally)					0.003	
FUEL INJECTION PUMP:						
Roller to roller dimension	1.9635	1.9645				
Transfer pump blades (determine wear by measuring length)			0.538			
MAIN BEARING:						
Clearance			0.0009	0.0034		

**Table 1-2.** Manufacturer's Torque Values

National Coarse

Dia. and pitch	Foot pounds	
	Minimum	Maximum
1/4 - 20	6	7
5/16 - 18	12	14
3/8 - 16	21	24
1/2 - 13	52	59
5/8 - 11	105	120
3/4 - 10	170	190

National Fine

Dia. and pitch	Foot pounds	
	Minimum	Maximum
1/4 - 28	5	6
5/16 - 24	9	10
3/8 - 24	14	16
1/2 - 20	40	42
5/8 - 11	60	70
3/4 - 16	100	120

**Table 1-3.** Manufacturer's Dimensional Tolerances (Air Compressor)

Model 234C2	Clearance		Dimension for disposal
	Minimum	Maximum	
Piston to bore:			
3 in. Cylinder dia.	0.0030	0.0040	0.0050
1-3/4 in. cylinder dia.	0.0025	0.0035	0.0045
Ring end gap (ring installed in bore) :			
Both cylinders	0.0050	0.0150	0.0200
Piston pin to piston:			
Both cylinders	0.0003	0.0009	0.0012
Piston pin to connecting rod:			
Both cylinders	0.0002	0.0007	0.00095
Crank pin bushing to connecting rod:			
Both rods	0.0010	0.0020	0.0025





## CHAPTER 2

## OPERATING INSTRUCTIONS

## NOTE

If equipment fails to operate, refer to troubleshooting procedures in chapter 3.

---

**Section I. PERATING PROCEDURES**

- 2-1. **GENERAL.** This section describes the various controls and instruments and provides the operator or crew sufficient information required to operate the shop set.
- 2-2. **CONTROLS AND INSTRUMENTS.** The purpose of the controls and instruments and the normal and maximum readings of the instruments are listed in the following subparagraphs and illustrated in the figures, cited by the applicable subparagraphs,
- a. Hydraulic Systems. The two hydraulic systems that raise and lower the top doors are each operated by a manually operated hydraulic pump shown in figure 2-1. Insert the handle in the lever on top of the pump to operate the pump. Turn the control valve clockwise to raise the doors and counterclockwise to lower the doors.
  - b. Instrument Panel Lights. The instrument panel lights shown in figure 2-2 are turned on with the battery switch shown in figure 2-2.
  - c. Tachometer. The tachometer indicates the engine speeds. Normal engine speed should be 1,800 rpm to develop 60-hertz current. The tachometer also serves as an hour-meter to show the hours that the engine has run.
  - d. Engine Starter Ignition Switch (Key lock). The switch is a three position switch, OFF, ON and START. The battery witch must be ON to energize switch. Turn key to START position,fter engine starts release key and it will return to the ON position.
  - e. Battery Switch. The battery switch (fig. 2-2) is used to open the 24-volt DC circuit between the battery and all 24-volt controls and instruments to prevent the drainage of DC current from the battery when the end item is not in use. All 24-volt controls, instruments, or engine safety devices will not function if the battery switch is OFF.
  - f. Throttle Control. The throttle control (fig. 2-2) is used to adjust the engine speed to any desired rpm, from idle to 1,800 rpm. Turn the handle counterclockwise and pull out to increase and push in to decrease engine rpm; then, turn handle clockwise until the throttle is locked in position, Reduce the engine rpm to idle speed before stopping engine.

NOTE: OTHER SIDE DOOR LIFTING PUMP  
LOCATED ON OPPOSITE SIDE OF  
SHOP SET.

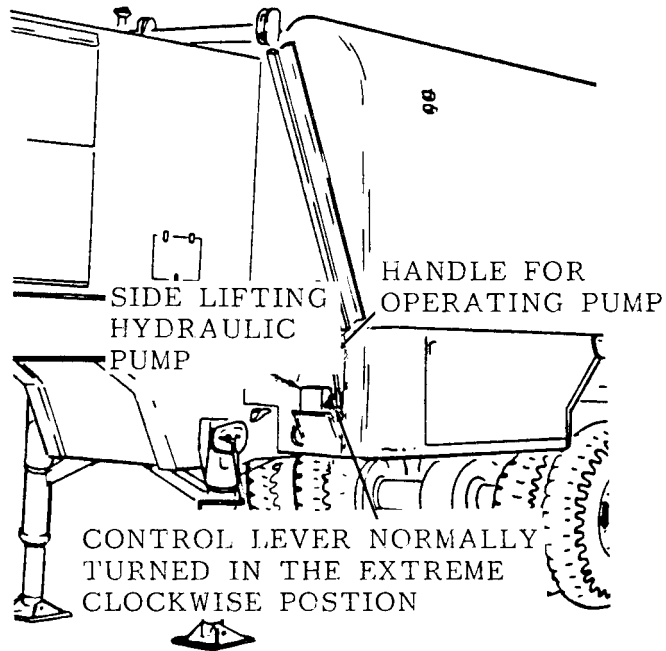


Figure 2-1. Hydraulic System Controls.

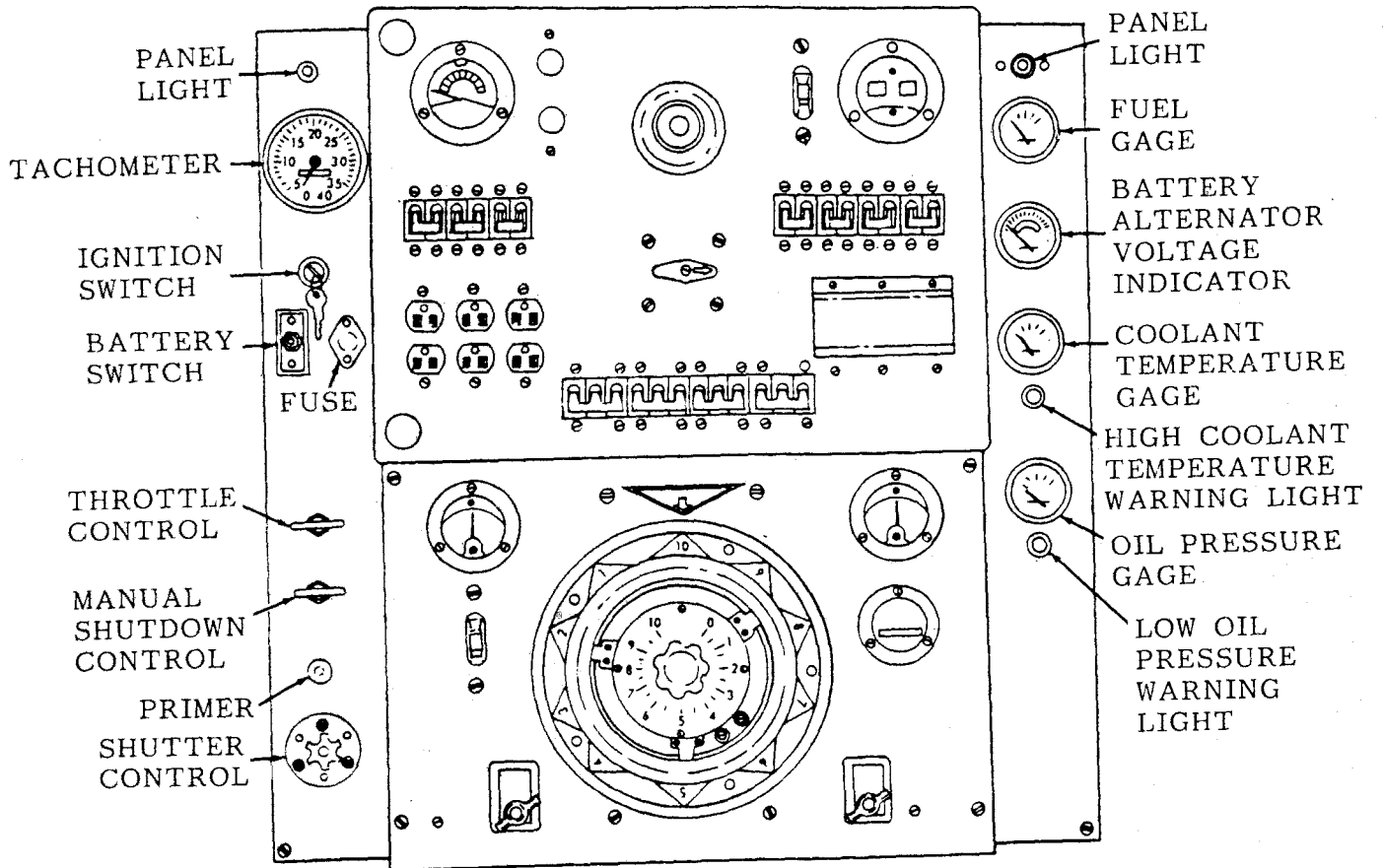


Figure 2-2. Engine Controls and Instruments.

- g. Manual Shutdown Control. A manual quick-stop control for stopping the engine. To stop the engine, pull the control out (fig. 2-2).
- h. Primer. For cold weather operation only. Do not operate unless engine is being cranked by the starting motor. Pressing the button actuates the starting aid solenoid.
- i. Shutter Control. The shutter control (fig. 2-2) is used to open and close the radiator shutters to decrease the engine warmup time, and to maintain normal engine temperature when operating in unusually cold temperatures. Turn knob counterclockwise to close shutters. Open shutters when the engine operating temperature reaches normal, by turning the knob clockwise. When the engine is running with the radiator shutters closed, constant surveillance of the instruments must be maintained to prevent damage to the engine by overheating.
- j. Fuel Level Gage. The fuel level gage (fig. 2-2) shows the amount of fuel in the engine fuel tank when the battery switch is turned on.
- k. Battery Alternator Voltage Indicator. The yellow and red on the left side of the battery generator voltage indicator (fig. 2-2), shows the condition of the batteries with the engine stopped and with the battery switch (fig. 2-2) turned on. The needle pointing to the separation between yellow and red indicates 22-volts, to red, indicates lower voltage; and yellow indicates higher voltage. When the engine is running, the green and red on the right side of the voltage indicator shows the DC voltage charging rate of the generator. The needle pointing to the offset at top of green, indicates 28-1/2 volt charging rate. When the engine is running at normal operating speed, the needle should point to green. If the needle points to red or yellow, stop the engine to prevent further damage to the charging system.
- l. Coolant Temperature Gage. The coolant temperature gage (fig. 2-2) indicates the temperature of the coolant in the engine. The normal operation temperature should be between 180° and 195° F.
- m. High Coolant Temperature Warning Light. The warning light, (fig. 2-2), warns the operator if the engine coolant temperature becomes too hot for the safe operation of the engine. If the coolant temperature reaches 212° F., the warning light will glow red, and the engine must be stopped to prevent damage.
- n. Oil Pressure Gage. The gage (fig. 2-2) indicates the engine oil pressure. When the engine is running at normal operating temperature and speed, the oil pressure should be 40 to 60 pounds. A cold engine will have a higher oil pressure and a hot engine will have lower oil pressure.

- o. Low Oil Pressure warning Light. The warning light acts as a warning to the operator if the engine oil pressure becomes too low for safe operation of the engine. The warning light will glow red when the battery switch is turned on, and will not glow when the engine is running". If the engine oil pressure drops to 10 psi, the warning light will glow and the engine must be stopped to prevent damage.
- p. Air Pressure Gage. The gage (fig. 2-3) shows the amount of air pressure in the shop set air system. During normal operation, it should read between 125 psi and 150 psi.
- q. Relief Valve. The relief valve (fig. 2-3) is a safety device to protect the air system and personnel if a malfunction occurs that will cause the pressure in the air system to exceed a safe working pressure. The relief valve will open to let the air pressure escape from the system when air pressure of 180 psi is reached.
- r. Pressure Switch. The switch (fig. 2-3) is a pressure-operated electric switch that automatically starts and stops the air compressor to maintain a minimum of 125 psi and a maximum of 150 psi.
- s. Start, Stop, and Reset Switch. The switches (fig. 2-3) are used to start and stop the air compressor system. The reset switch will automatically disengage when a mechanical or electrical malfunction occurs in the air system that causes the electrical circuit to be overloaded.
- t. AC Voltmeter. The AC voltmeter (fig. 2-4) indicates the AC voltage output of the generator portion of the dynamotor-welder, when the dynamotor-welder is driven by the shop set engine. The output voltage is regulated by the AC voltage adjusting rheostat, and the AC voltmeter indicates the adjusted voltage, which will normally be 240 volts. The same AC voltmeter will indicate only the incoming voltage when an external source of electrical power is used to run the dynamotor-welder; or for the emergency circuits, normally 240 volts for the dynamotor-welder and 120 volts for the emergency circuits.
- u. Dynamotor Start-Stop Switch. This switch (fig. 2-4) is used to start and stop the dynamotor-welder when an external electrical power source is used, and also to close the contractor to provide AC power when the dynamotor-welder is driven by the shop set engine. To operate the switch, press the button momentarily to stop or start.
- v. AC Voltage Adjusting Rheostat. This rheostat (fig. 2-4) regulates only the output AC voltage of the generator portion of the dynamotor-welder, from the minimum to the maximum. Turn handle clockwise to increase and counterclockwise to decrease AC voltage.
- w. Frequency Switch. The frequency switch (fig. 2-4) should be set on 60 hertz if 60 hertz external power is used to run the dynamotor-welder; or, if the engine governor is adjusted so that the shop set engine will run at 1,800 rpm to cause the dynamotor-welder to develop 60 hertz AC current. The switch should be set on 50 hertz if 50 hertz external power is used.

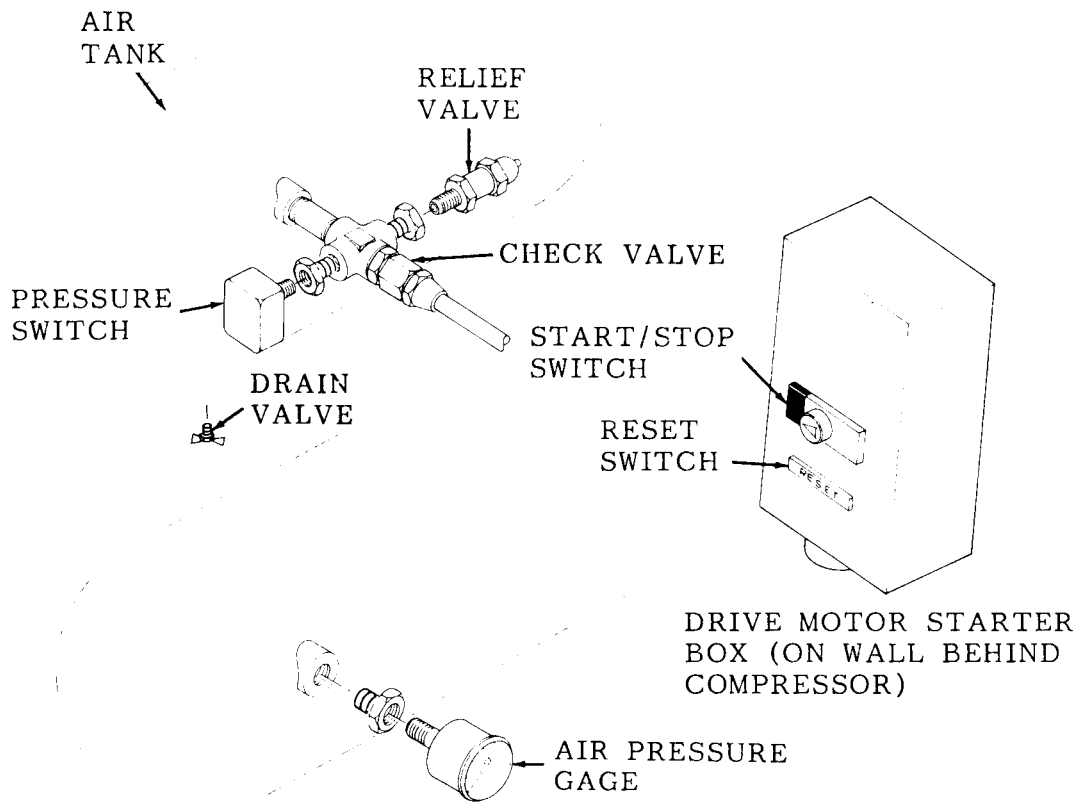


Figure 2-3. Air Compressor Drive Motor Control and Air Receiver Tank Pressure Gage.

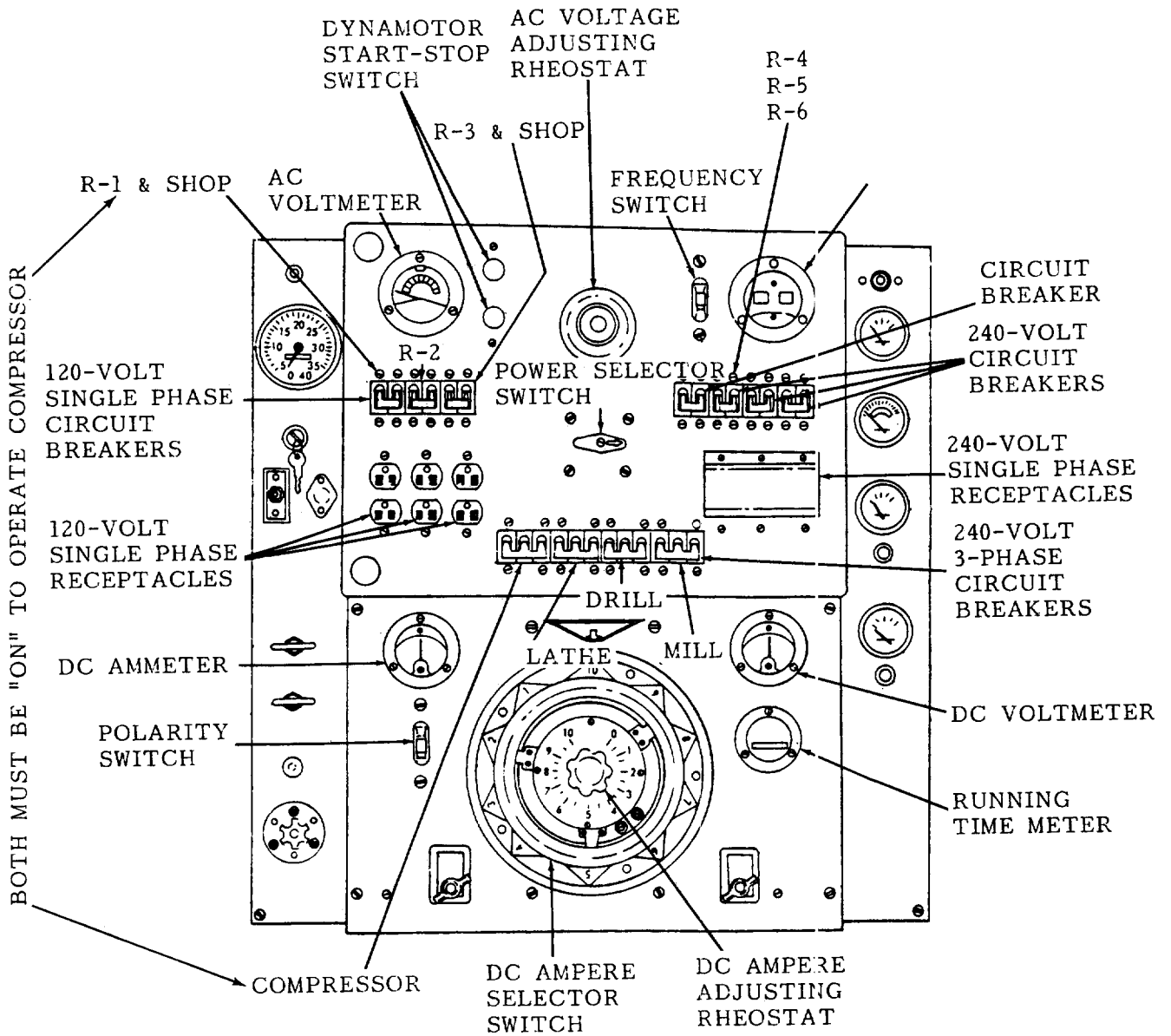


Figure 2-4. Electrical System Control Panel.

- x. Frequency Meter. The frequency Meter (fig. 2-4) indicates the hertz of incoming power when an external electrical power source is used, and indicates the hertz of output power when the dynamotor-welder is driven by the shop set engine. Normal reading is 60 hertz when the engine is driving the dynamotor-welder at 1, 800 rpm.
- y. 120-volt, Single-Phase Circuit Breakers. The circuit breakers (fig. 2-4 ) protect these circuits against overloading which could be connected to the 120-volt, single-phase receptacles. These circuit breakers are rated at 30 amperes each.
- z. 120-Volt, Single-Phase Receptacles. 120-volt, single-phase power is available at the three receptacles (fig. 2-4) , R1, R2, and R3, when the dynamotor-welder is powered by the shop set engine or by an external power source. Only the R3 receptacle will transmit 120-volt, single-phase power, when using only 120-volt emergency power.
- aa. Power Selector Switch. The power selector switch (fig. 2-4) sets the control panel for the source of power that will be used to run the dynamotor-welder and/or the shop set.
  - (1) In GENERATOR position, the dynamotor-welder is driven by the shop set engine. The generator portion of the dynamotor-welder will produce AC current regulated by the AC voltage adjusting rheostat. Power is available at all terminals and receptacles. DC current up to 300 amperes and 32 volts is available for welding.
  - (2) In CITY position, an external source of 240-volts AC 3-phase power is connected to the input receptacle. The generator portion of the dynamotor-welder is now used as a 25 H. P. synchronous motor to drive the welder portion. AC power is available at all terminals and receptacles, as well as DC power for welding.
  - (3) In EMRGENCY position, an external source of 120-volt AC single-phase power is connected to the shop set. The shop set lights and R3 receptacle on the control panel can be used.
  - (4) In OFF position, all AC circuits are de-energized. When the engine is running at 1,800 rpm, the welding studs are energized for normal welding operations.
- ab. Control Circuit Breaker. The function of the control circuit breaker
- ac. 240-Volt Circuit Breakers. These 3 circuit breakers (fig. 2-4) protect the three 240-volt, single-phase receptacle circuits R4, R5, and R6 from overloading in excess of 10 ampere for each receptacle.
- ad. 240-Volt, Single-Phase Receptacles. These receptacles (fig. 2-4) are twist-lock type and will transmit a maximum of 10 amperes of electric current when the generator portion of the dynamotor-welder is driven



by the engine or an external source of 240 Vac electrical power. Electrical power is also available when the external 240 Vac power source is connected to the shop set and the dynamotor-welder is stopped,

- ae. 240-Volt, 3-Phase, Circuit Breakers. These 4 circuit breakers (fig. 2-4) protect the air compressor and lathe electrical circuits from overloading in excess of 30 and 40 amperes, respectively. They also protect the grinding and milling attachment circuits from overloading in excess of 15 amperes each.
- af. DC Ammeter. The ammeter (fig. 2-4) indicates the amperage of DC welding current only when welding is actually being accomplished. The normal reading will vary with the amperage range selected at the DC ampere selector switch and the fine adjustment made at the DC ampere adjusting rheostat.
- ag. Polarity Switch. The polarity switch (fig. 2-4) is used to direct the flow of DC welding amperes from the welding rod to the material (straight polarity) or to direct the flow of amperes from the material to the welding rod (reverse polarity). The switch must be OFF when welding is not being performed to prevent possible damage.
- ah. DC Ampere Selector Switch. The switch (fig. 2-4) is used to select the welding ampere range required for all welding to be accomplished. Amperes lower than 30 are available for special application and up to 300 amperes for general welding. Each welding ampere range shown on the switch shows a minimum and a maximum for the range selected, that should be further adjusted with the DC ampere adjusting rheostat.
- al. DC Ampere Adjusting Rheostat. This rheostat (fig. 2-4 ) regulates the DC welding amperage within the ampere range selected at the DC ampere selector switch. This rheostat may be removed from the control panel and moved to the welding site for remote fine adjustment of DC amperage by using a suitable electrical cable to connect between the rheostat and the receptacle that the rheostat was originally plugged into. Turn the adjusting rheostat' clockwise to increase welding amperage and counterclockwise to decrease amperage.
- aj. DC Voltmeter. The DC voltmeter indicates the DC voltage output of the welder and will show a maximum of 32 volts.
- ak. (Overspeed Safety Switch. The overspeed safety switch (fig. 2-5) will shut the engine down at approximately 2,000 rpm or 66 hertz.

### 2-3. STARTING THE ENGINE.

- a. General. The function of the shop set engine is to provide power for the dynamotor-welder.
- b. Starting the Engine. Refer to figure 2-6, and start the shop set engine.

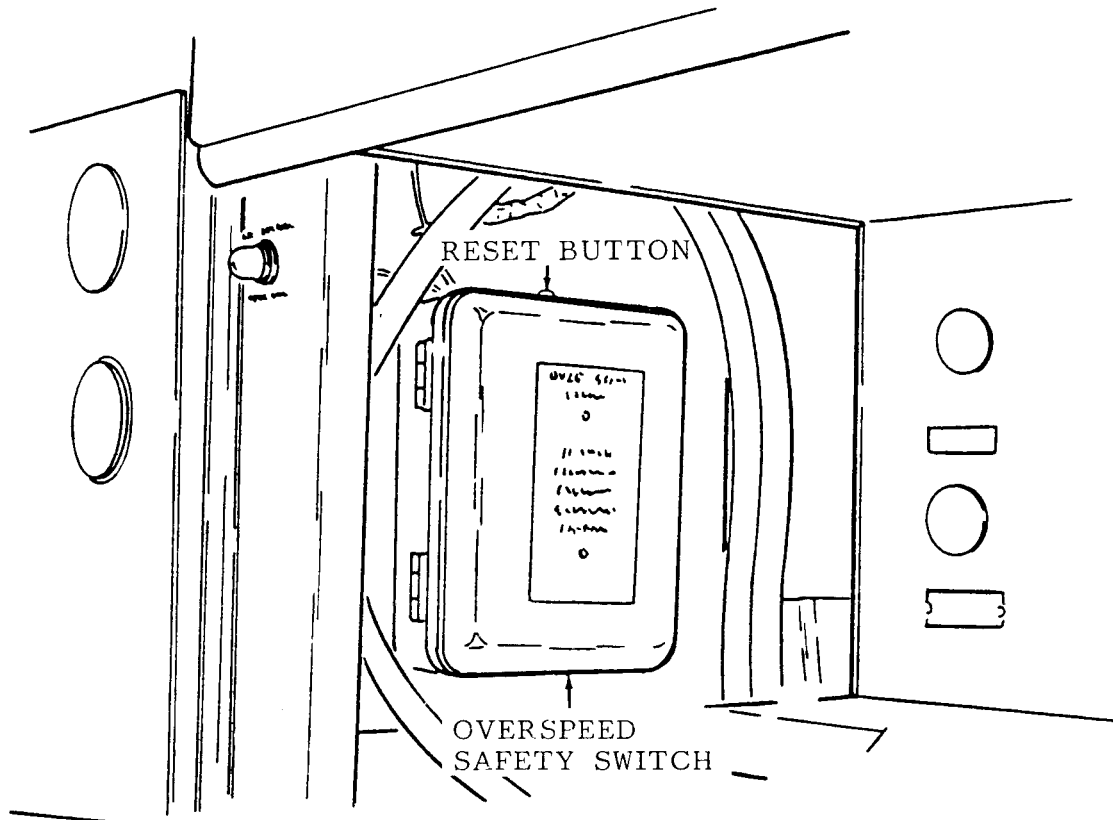


Figure 2-5. Overspeed Safety Switch.

- c. Speed Adjustment for 60-Hertz AC Output. Adjust throttle control to give tachometer reading of 1,800 rpm.

### NOTE

Engine governor will maintain adjusted speed under various load conditions.

**2-4. STOPPING THE ENGINE.** Refer to figure 2-7 and stop the engine.

### 2-5. OPERATION OF EQUIPMENT.

a. Operation on Internal Power (Shop Set Equipment).

- (1) Place all circuit breakers and switches on the control panels in the OFF position.
- (2) Start the engine (fig. 2-6).
- (3) Adjust the engine speed to the desired rpm (para. 2-3). The engine should be operated at 1,800 rpm for 60-hertz current.
- (4) Set power selector switch to GENERATOR and the frequency switch to 60 hertz.
- (5) Place the control circuit breaker (fig. 2-4) to ON position, and press the dynamotor start switch, momentarily, to energize the AC generator portion of the dynamotor-welder.

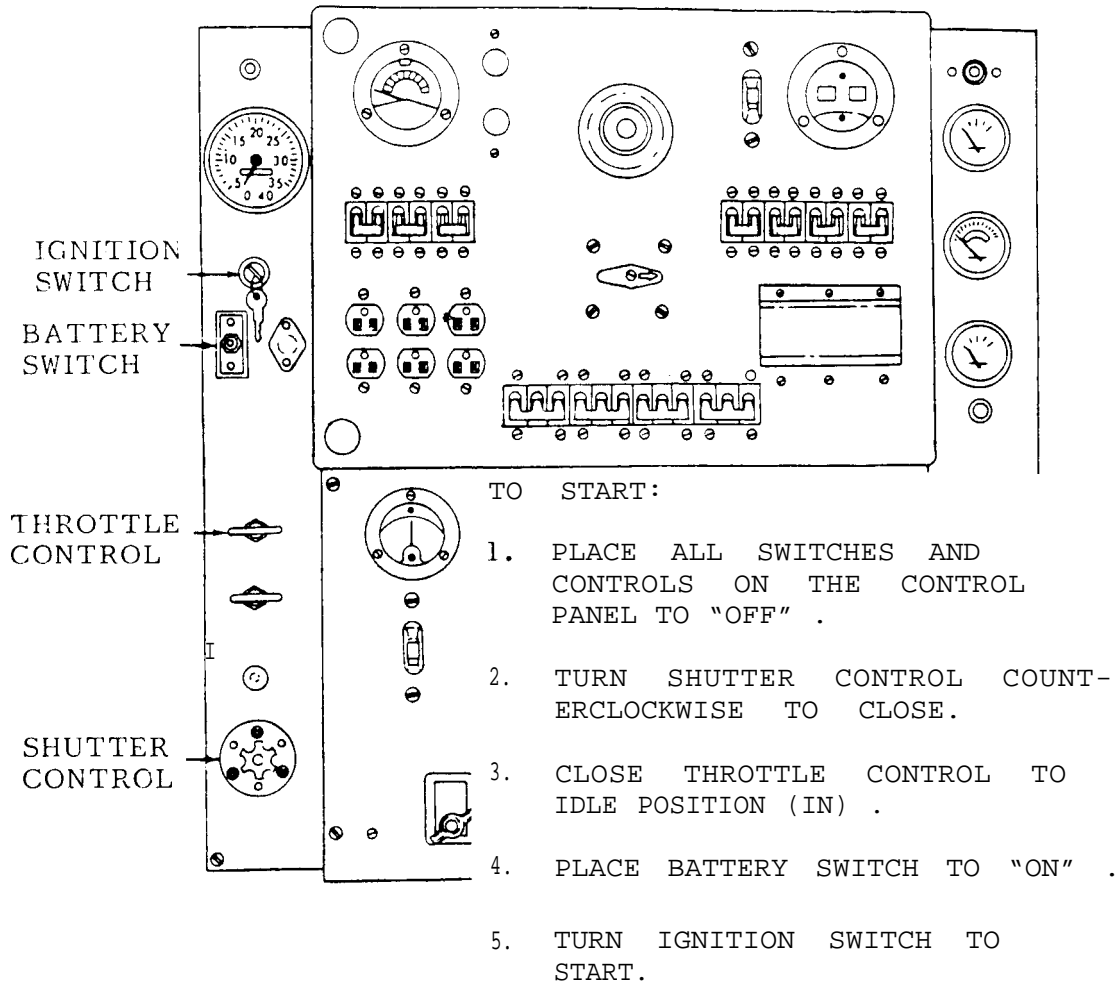
### NOTE

With selector switch in GENERATOR position, the welder is driven in the proper rotation. All sequences of operation duplicate CITY position except 240-V EXTERNAL power receptacle which is now output rather than input.

### NOTE

AC output voltage adjustments may be made with the AC voltage adjusting rheostat (fig. 2-4). DC output adjustments may be made with the DC ampere selector switch and DC ampere adjusting rheostat (fig. 2-4).

- (6) After the operator performs steps 1 through 5, the synchronous motor becomes an AC generator. Power is available at all terminals and receptacles. The dynamotor-welder provides power for welding.



**CAUTION**

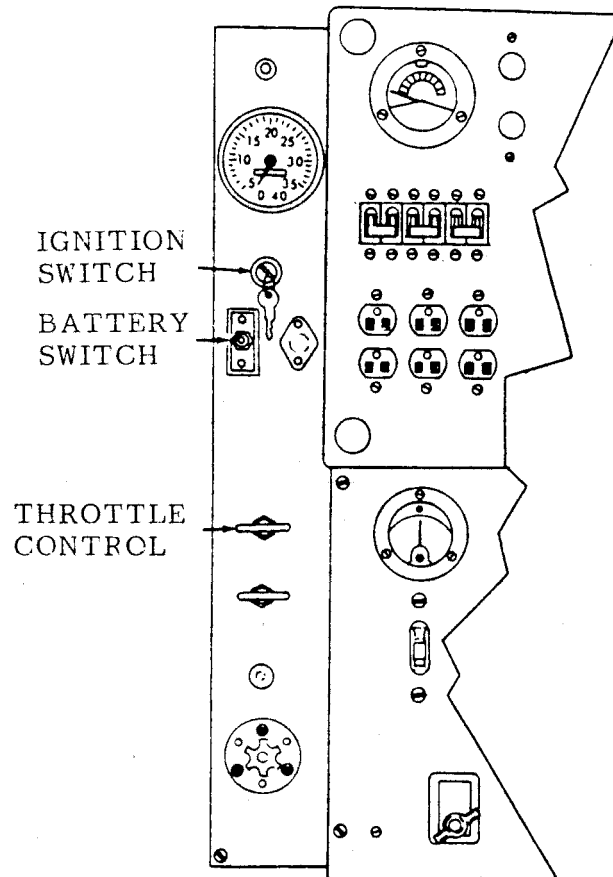
IF ENGINE FAILS TO START WITHIN 30 SECONDS RELEASE IGNITION SWITCH AND ALLOW STARTER TO COOL FOR 2 MINUTES BEFORE TRYING TO RESTART ENGINE.

6. GRADUALLY OPEN RADIATOR SHUTTERS AS THE ENGINE COOLANT TEMPERATURE RISES.

**CAUTION**

OBSERVATION OF THE CONTROL PANEL MUST BE MAINTAINED WHEN THE RADIATOR SHUTTERS ARE NOT OPEN.

Figure 2-6. Starting the Shop Set Engine.



TO STOP:

1. UNLOCK THRHITTLE CONTROL AND PUSH IN AND ALLOW ENGINE TO IDLE.
2. TURN IGNITION SWITCH "OFF" .
3. TURN BATTERY SWITCH "OFF" .

Figure 2-7. Stopping the Shop Set Engine.

b. Operation on External (CITY) Power.

- (1) Place all switches and circuit breakers in the OFF position.
- (2) Set the frequency switch to match the rating of the incoming power; either 50 or 60 hertz, and place the power selector switch in the CITY position.
- (3) Connect the external power source (fig. 4-9). The external power source must be 240 volts.

**NOTE**

With the selector switch in the (CITY) position, connect outside source of 3-phase, 240-volt A. C. power to power receptacle. 240-volt single-phase power can now be used from R4, R5, and R6 receptacles. Also, the air compressor, lathe, drill press, and mill may be operated. Place the control circuit breaker (fig. 2-5) in the ON position and press the dynamotor-welder start switch momentarily. The generator portion of the dynamotor-welder is now functioning as a 25 H. P. motor to drive the welder portion.

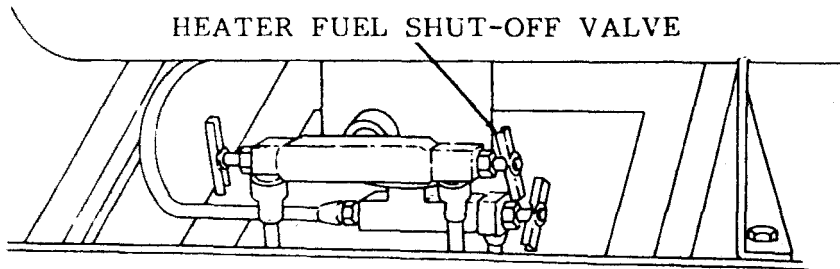
**CAUTION**

Check rotation of dynamotor-welder. The correct rotation is clockwise from the driving end. To correct the rotation, interchange any two of the incoming power leads.

- (4) Check the reading of the frequency meter which indicates the correct frequency of the incoming power. If it is not compatible with the frequency switch setting, set switch correctly. The AC voltmeter will indicate input voltage. Power is now available from all terminals and receptacles. The welder is driven by the synchronous motor.

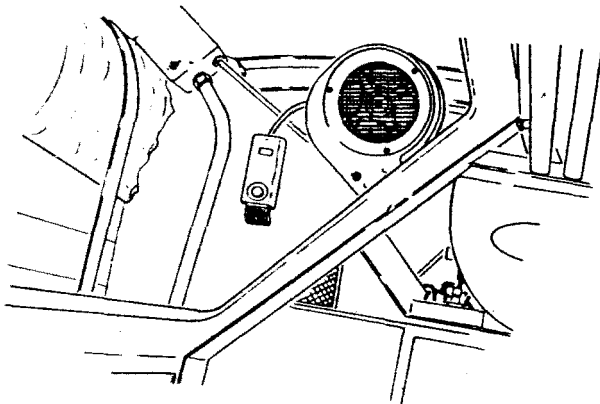
c. Operation on EMERGENCY Power.

- (1) General. When neither internal nor 3-phase, 240-volt AC external power is available, it is impossible to operate the dynamotor-welder or to provide current to the shop set contents. Under these conditions, an external 120-volt, single-phase 50-60 hertz current may, if available, be used to furnish power for limited operation of the shop set components.
- (2) Operational procedure.
  - (a) Make sure all switches throughout the shop set are in the



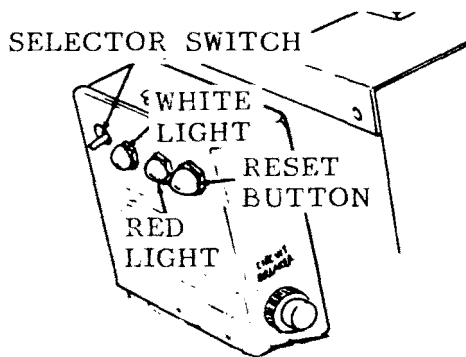
1. OPEN THE HEATER SHUT-OFF VALVE BEFORE STARTING HEATER.

A. VALVES



2. ADJUST THERMOSTAT SETTING 5 DEGREES ABOVE AMBIENT TEMPERATURE.

B. THERMOSTAT



3. PLACE SELECTOR SWITCH AT "HEATER".
4. OPEN FUEL SHUT-OFF VALVE AT FUEL PUMP.
5. WHITE LIGHT INDICATES HEATER IS "ON" AND OPERATING NORMALLY.
6. IF RED LIGHT COMES ON AND HEATER STOPS, CHECK FOR FUEL OF IGNITION FAILURE. PUSH "RESET BUTTON" TO RESTART HEATER.
7. TO STOP HEATER TURN SELECTOR SWITCH TO "OFF". HEATER WILL SHUT OFF WHEN COOL.

c. HEATER

**NOTE**

FOR AIR CIRCULATION WITHOUT HEATING, SET SELECTOR SWITCH AT "FAN".

Figure 2-8. Personnel Heater Controls and Operation.

OFF position and that no equipment or appliance is plugged into the 120-volt shop set receptacles.

- (b) Place the power selector switch in the EMERGENCY position.
  - (c) Connect the emergency power source by opening the access door on the street side of the engine housing assembly and plugging in the EMERGENCY power supply lead.
  - (d) Observe the frequency meter and set the frequency switch to either 50 or 60 hertz as indicated by the meter.
  - (e) Place R3 circuit breaker in the ON position.
  - (f) 120-V power is available from R3 duplex receptacles ONLY. Shop shop lights are also operational.
- d. Operation with Power Selector Switch in OFF Position. To develop DC current for welding, when AC current for operating shop set is not desired, turn the power selector switch (fig. 2-4) OFF. Then, refer to figure 2-6, start the engine and accelerate to 1,800 rpm. The required DC current is now available.

#### NOTE

Experience alone will enable the operator to determine the correct DC ampere and polarity required for the particular welding to be accomplished.

- e. Welder Operation.

#### NOTE

Refer to TM 9-237 for welding techniques.

- (1) Refer to paragraph a, and energize the system with internal power; refer to paragraph b, and energize the system with external power, or, refer to paragraph 2-5d.
- (2) Connect electrode and ground cable to dynamotor-welder output terminals (positive electrode and negative ground) .
- (3) Place the polarity switch in the desired position.
- (4) Turn the DC ampere selector switch (fig. 2-4) so that the desired amperes (welding) range is directly under the arrow of the selector switch. The DC ampere fine adjustment rheostat located in the center of the selector switch can now be adjusted to the desired amperes within the range shown at the top of the



range selector switch. For remote fine adjustment at the welding area, remove the fine adjustment rheostat assembly, pressing upward on the latch under the handle of the rheostat and pulling outward. Install appropriate cable between rheostat and outlet.

**CAUTION**

Do not change the setting of the DC ampere range selector switch, or the fine adjustment while welding is being performed.

- (5) Place the polarity switch in the OFF position when welding is not being performed, to prevent possible damage to the circuit. To stop the dynamotor-welder from developing DC current, the rotation of the dynamotor-welder must be stopped.
  - (a) When the shop set engine is, the power source and you have been operating with the power selector switch (fig. 2-4) in OFF position, reduce engine speed to lower than 900 rpm to de-activate the centrifugal clutch.
  - (b) When the shop set engine is the power source, and you have been operating with the power selector switch in GENERATOR position, press the dynamotor stop switch (fig. 2-4) and then reduce the engine speed to lower than 900 rpm.
  - (c) When external power source is used, momentarily press the dynamtor stop switch.

f. Air Compressor Operation.

- (1) Energize the electrical system as explained in paragraph 2-5a or b.
- (2) Switch on air compressor circuit breaker and circuit breaker R1 (fig. 2-4).
- (3) Open air receiver draincock (fig. 2-3) and drain condensation from tank.
- (4) Press start switch (fig. 2-3) to start.
- (5) To stop compressor, push stop button and place the air compressor circuit breaker OFF.
- (6) The air compressor pressure switch (fig. 2-3) will automatically shut down the compressor when pressure reaches 150 psi; and will re-start the co-repressor as soon as pressure falls below 125 psi.

g. Lathe Operation.

- (1) Energize the electrical system as explained in paragraph 2-5a or b.

(2) Switch lathe circuit breaker (fig. 2-4) ON.

(3) Lathe may now be operated.

h. Drill Press Operation.

(1) Energize the electrical system as explained in paragraph 2-5a or b.

(2) Switch drill press circuit breaker (fig. 2-4) ON.

(3) Press start switch on drill press control box.

(4) Drill press may now be operated.

i. Mill Operation.

(1) Energize the electrical system per subparagraph a or b.

(2) Remove hardware that secures the milling attachment in its stored position, and install on the lathe cross slide in place of the compound slide.

(3) Switch the mill circuit breaker ON.

(4) Operate the mill from installed position .

**NOTE**

Experience alone will enable the operator to install the milling attachment on the lathe to the position that will produce the best results.

j. 120-Volt, Single-Phase Receptacles.

(1) Energize the electrical system for either "internal or external power.

(2) Switch the R1, R2, and R3 circuit breaker (fig. 2-4) ON. This will energize the R1, R2, R3, and other 120-volt, single-phase receptacles.

**NOTE**

On emergency power, only receptacle R3 may be utilized.

- k. 240-Volt, Single-Phase Receptacles.
- (1) Energize the electrical system for either internal or external power.
  - (2) Switch the R4, R5, and R6 circuit breakers (fig. 2-4) ON. This energizes the R4, R5, R6, and other 240-volt, single-phase receptacles.

## Section II. OPERATION OF AUXILIARY MATERIEL USED IN CONJUNCTION WITH THE SHOP SET

### 2-6. FIRE EXTINGUISHER (CARBON DIOXIDE TYPE).

- a. Description. The carbon dioxide type fire extinguishers are suitable for electric and flammable liquid fires. The carbon dioxide types are of the 4-pound, 7-1/2 pound, and 15-pound sizes. The 4-pound extinguisher is portable; the others are the fixed type.
- b. Operation. Remove the fire extinguisher from its location, break the seal, operate the control valve, and direct the stream at the base of the flame.
- c. Maintenance. For maintenance of the fire extinguisher, refer to TB 5-4200-200-10.

### 2-7. PERSONNEL HEATER. For starting and stopping instructions, refer to figure 2-8.

## Section III. OPERATION UNDER UNUSUAL CONDITIONS

### 2-8. OPERATION IN EXTREME COLD.

- a. Engine and Air Compressor. Refer to current lubrication order for cold weather lubrication instructions.
- b. Dynamotor-welder. When the dynamotor-welder is driven by the shop set engine during extremely cold operating conditions, allow a warming-up period to allow the engine to reach normal operating temperature range before operating the dynamotor-welder.
- c. Wiring. Do not attempt to service or move the wiring during extremely cold temperatures. Bending a wire under these conditions will cause cracks and breaks in the insulation and the wiring itself, since cold temperatures make wiring brittle.
- d. Cooling System. Make sure the coolant is treated for the lowest possible ambient temperatures to be encountered. Refer to TB 750-651. Clean and flush the cooling system before adding the initial anti-freeze mixture. Make sure the thermostats are in proper working order.

NOTE

If the radiator shutters are partially closed during operation, to maintain normal operating temperature, the control panel must be frequently observed to prevent overheating.

- e. Fuel System. Fuel tank should be kept as full as possible at all times to reduce the possibility of moisture forming in the tank. Service the fuel filters (paras. 8-4 and 8-5 ) as necessary, to remove any accumulated water or ice. Keep the fuel tank filler cap and screen free from ice and moisture. Use the fuel primer pump (fig. 2-2 ) to start the engine in cold weather.
- f. Batteries. A fully charged battery can withstand extreme cold while a partially charged battery may freeze and crack the cells. Refer to TM 9-6140-200-12 for electrolyte specific gravity readings at various temperatures. Make sure electrolyte level is above the battery plates. Add distilled water as necessary.

**CAUTION**

Run the engine to charge the batteries for at least 30 minutes after adding water. This will mix the water and electrolyte thoroughly and prevent freezing.

**2-9. OPERATION IN EXTREME HEAT.**

- a. Lubrication. Refer to current lubrication order and lubricate with specified lubricants only.
- b. Engine Cooling System. Keep the cooling system free of scale and rust. Check coolant frequently and maintain proper level. Drain and flush frequently; fill with clean water. Make sure the thermostats and shutter are in good working order and that the fan belt tension is correct. The radiator shutters must be open during operation.
- c. Batteries. Check battery electrolyte level and add distilled water as necessary.
- d. Dynamotor-Welder. Check the dynamotor-welder air filters frequently. Clean, ventilating air filters are necessary to maintain maximum ventilation through the dynamotor-welder at all times.

**2-10. OPERATION IN DUSTY OR SANDY AREAS.**

- a. General. Dust and dirt can cause premature mechanical failure of the shop set components. Locate the shop set in a well protected area, whenever possible. Keep the shop set as clean as possible, paying particular attention to the screens, grills, and filters. Use compressed air to clean, for best results.

- b. Lubrication, Strainers and filters will have to be replaced more often than usual. Take care to clean dust and dirt from the lubrication points before applying lubricant. Clean the area around the oil filler cap and oil level gage before checking oil level or adding oil.
- c. Cooling System. Inspect cooling system frequently for leaks and improper operation. Keep radiator filler cap tightly secured and be sure the fan belts are adjusted to the proper tension. Clean and flush the cooling system regularly.
- d. Fuel System. Take all precautions to keep the fuel and fuel system free from dust and foreign particles. Inspect the filters more frequently than under normal circumstances.
- e. Dynamotor-Welder. Inspect the dynamotor-welder filter screens frequently to keep dust and dirt to a minimum.

#### 2-11. OPERATION UNDER RAINY OR HUMID CONDITIONS.

- a. General. Provide adequate ventilation and shelter to protect the shop set from rain and humidity. Remove any coverings during dry period to aid in drying out the shop set and components.
- b. Fuel System. Keep fuel tank full to avoid condensation in the tank.
- c. Dynamotor-Welder. Do not attempt to weld in the direct presence of rain or when condensate is forming on metal parts in an extremely humid atmosphere.

#### 2-12. OPERATION IN SALT WATER AREAS.

- a. General. Wipe the exposed surfaces of the body interior and exterior, as well as all component surfaces, with clean, fresh water. Be careful not to contaminate the fuel system or damage the electrical system with the water.
- b. Protection. Remove all rust and corrosion immediately. Coat exposed metal surfaces with rust-proofing material and apply paint or oil as required.
- c. Cooling System. Be sure the water used in the cooling system is not salt water. The cooling system is not intended for use with salt water; however, salt water may be used in an emergency. After such an emergency, be sure to drain and flush the cooling system thoroughly.

**2-13. OPERATION AT HIGH ALTITUDES.** Operating difficulties at high altitudes result largely from the reduced density of the atmosphere. This affects the shop set primarily in regards to the ventilation and cooling of components. The dynamotor-welder AC and DC outputs are both rated at 12KW at altitudes up to 5,000 feet. To calculate either AC or DC output above 5,000 feet elevation, use the following formula: (round off to closest tenth).

**KW FORMULA FOR HIGH ALTITUDES**

(Standard rating is 12KW at altitudes from 1,000 to 5,000 feet)

$$6\% \times \frac{\text{Actual Altitude} - 5,000 \text{ feet}}{1,000 \text{ feet}} \times 12\text{Kw} = \text{KW Derating Factor.}$$

EXAMPLE :

$$1. \quad 6\% \times \frac{11,000 \text{ feet} - 5,000 \text{ feet}}{1,000 \text{ feet}} \times 12\text{KW} = \text{KW Derating Factor.}$$

$$2. \quad 6\% \times \frac{6,000 \text{ feet}}{1,000 \text{ feet}} \times 12\text{KW.}$$

$$3. \quad .06 \times 6 \text{ feet} \times 12 \text{ KW.}$$

$$4. \quad .36 \times 12\text{KW} = 4.32 \text{ KW Derating Factor.}$$

$$5. \quad 12\text{KW Standard Rating} - 4.32 \text{ KW Derating Factor} = 7.68 \text{ KW.}$$

6. So, 7.68 KW (or 7.7 KW) is the actual rating at 11,000 feet altitude.

## CHAPTER 3

### OPERATOR/CREW MAINTENANCE INSTRUCTIONS

---

#### Section I. LUBRICATION

##### 3-1. GENERAL LUBRICATION INFORMATION.

- a. This section contains lubrication instructions which are supplemental to and not specifically covered in the lubrication order.
- b. For the current lubrication order, refer to LO 9-4940-430-12.
- c. Lubrication instructions for shop components are contained in the components manual.

##### 3-2. DETAILED LUBRICATION INFORMATION .

- a. Care of Lubricants. Store all lubricants in closed containers and keep them in a clean, dry area, away from heat. Keep all lubrication equipment clean and ready for use.
  - b. Cleaning.
    - (1) Wipe areas around the points of lubrication before and after applying lubricant.
    - (2) Always keep shop set free of spilled lubricant.
  - c. Operation After Lubrication. After each engine oil change, start the engine and check the oil pressure. If oil pressure is not indicated within 30 seconds, stop engine and check oil level. Add oil if necessary. Inspect the oil filter, oil lines, and connections for leaks.
- 

#### Section II. PREVENTIVE MAINTENANCE CHECKS AND SERVICES

- 3-3. GENERAL.** To insure that the shop set is ready for operation at all times, it must be inspected systematically so that defects may be discovered and corrected before they result in serious damage or failure. The necessary preventive maintenance checks and services to be performed are listed in table 3-1. Defects discovered during operation of the unit will be noted for future correction, to be made as soon as operation has ceased. Stop operation immediately if a deficiency is noted which would damage the equipment if operation were continued. All deficiencies and shortcomings will be recorded, together with the corrective action taken, on DA Form 2410 (Equipment Inspection and Maintenance Worksheet) at the earliest possible opportunity.
- 3-4. PREVENTIVE MAINTENANCE CHECKS AND SERVICES.** Refer to table 3-1 for a list of checks and services.

Table 3-1. Operator/Crew Preventive Maintenance Checks and Services

B-Before Operation

D-During Operation

A-After Operation

Interval and Sequence No.			Item to be Inspected Procedure
B	D	A	
1			Radiator Proper coolant level is 2-inches below filler neck.
2			Fuel Filters Drain sediment. Tighten loose mounting connection.
	14		Air Pressure Gage Check for normal reading of 125-150 psi,  Air Receiver Drain condensate. Tighten loose mounting and connections.
3		20	Tires and Wheels Check for cut or badly worn tires. Replace a damaged wheel.
4	15	21	Lights and Reflectors Replace burned out lamps. Replace cracked lenses.
5		22	Airbrake System Drain condensate from air tank.
	16		Circuit Breakers Inspect for defective circuit breakers.
6			Oil Level Gage Add oil as indicated by level gage.
7			Fuel Tank Add fuel as required.



Table 3.1. Operator/Crew Preventive Maintenance Checks and Services

B-Before Operation

D-During Operation

A-After Operation

Interval and Sequence No.			Item to be Inspected Procedure
B	D	A	
8			<p>Batteries Remove corrosion. Inspect for cracks and leaks. Tighten loose cables and mountings. Fill to 3/8-in. above plates with distilled water. Clean vent hole. In freezing weather run engine a minimum of 1 hour after adding distilled water.</p>
9			<p>Hydraulic System Add oil as required. Check for leaks.</p>
10	17		<p>Welder Controls and Instruments Inspect for damage and loose mounting. With unit operating, check for proper operation.</p> <p>Normal operating readings are as follows: AC Voltmeter: 240-volts Frequency Meter: 50-60 hertz DC Voltmeter: Terminal voltage DC Ammeter: Not to exceed 300 amps</p>
11	18		<p>Engine Controls and Instruments Inspect for damage and loose mounting. With unit operating, check for proper operation.</p> <p>Normal operating readings are as follows: Water temperature gage: 180-195°F. Oil pressure: 40-60 psi Battery generator indicator: pointer to green Tachometer: 1,800 rpm at 60 hertz</p>

Table 3-1. Operator/Crew Preventive Maintenance Checks and Services

B-Before Operation

D-During Operation

A-After Operation

Interval and Sequence No.			Item to be Inspected Procedure
B	D	A	
12		23	Fire Extinguisher Check for broken seal.
	19		Operation During operation, observe for any unusual noise or vibration.
13			Grounding Check for proper ground.

---

## Section III. TROUBLESHOOTING

### 3-5. GENERAL.

- a. This section contains troubleshooting information for locating and correcting most of the operating troubles which may develop in the shop set. Each malfunction for an individual component, unit or system is followed by a list of tests or inspections which will help you to determine corrective actions to take. You should perform the tests/inspections and corrective actions in the order listed.
- b. This manual cannot list all malfunctions that may occur, nor all tests or inspections and corrective actions. If a malfunction is not listed or is not corrected by listed corrective actions, notify your supervisor.
- c. The table lists the common malfunctions which you may find during the operation or maintenance of the shop set, or its components. You should perform the tests/inspections and corrective actions in the order listed.

Table 3-2. Troubleshooting

WARNING	
MALFUNCTION	The diesel fuel used in the engine for the Dynamotor-Welder is combustible. Use caution when draining/filling fuel tank and
TEST OR INSPECTION	working on the fuel system. Extinguish all smoking materials
CORRECTIVE ACTION	and do not allow sparks or open flame near the fuel tank and fuel system.

1. Engine Fails to Start or Hard to Start.
  - Step 1. Fuel tank empty.
    - Service Fuel tank.
  - Step 2. Fuel tank valve closed.
    - Open fuel tank valve.
  - Step 3. Fuel filters dirty or clogged.
    - Service fuel filters (paras. 3-9, 8-4, and 8-5).
  - Step 4. Fuel contamination.
    - Drain-and service with clean fuel.
  - Step 5. Fuel incorrect for conditions,
    - Fill with correct grade of fuel.
  - Step 6. Engine too cold to ignite fuel properly.
    - Perform cold weather starting procedures.
  - Step 7. Stop control in stop position.
    - Push control level in.
    - If problem still exists, notify supervisor.
2. Engine Stops or Runs Erratically.
  - Step 1. Air cleaner dirty.
    - Service air cleaner (para. 3-8).
  - Step 2. Fuel tank empty.
    - Service fuel tank.
  - Step 3. Fuel tank vent plugged.
    - Clean fuel tank vent.

Table 3-2. Troubleshooting-Continued

---

MALFUNCTION	TEST OR INSPECTION	CORRECTIVE ACTION
3. Engine Knocks or Develops Excessive Noise.	Crankcase oil supply low.	Add oil to proper level. If noise continues with oil at proper level, stop engine and notify your supervisor.
4. Engine Stops Suddenly.	Step 1. Fuel tank empty.	Fill fuel tank.
	Step 2. Dynamotor-welder overspeed safety switch trips.	Reset switch (fig. 2-5) If switch trips again, notify your supervisor.
5. Engine Overheats.	Step 1. Radiator shutter closed.	Open radiator shutter.
	Step 2. Coolant low.	Fill cooling system.
6. Engine Exhaust Smoke Black.	Step 1. Air cleaner dirty.	Service air cleaner (para. 3-8).
	Step 2. Crankcase oil level too high.	Drain oil to proper level.
	Step 3. Fuel tank vent plugged.	Clean fuel tank vent.

Table 3-2. Troubleshooting-Continued

---

**MALFUNCTION**

**TEST OR INSPECTION**

**CORRECTIVE ACTION**

---

7. Engine Lacks Power.

Step 1. Air cleaner dirty.

Service air cleaner (para 3-8).

Step 2. Fuel filters dirty.

Service or replace fuel filters (paras. 3-9, 8-4, and 8-5).

Step 3. Crankcase oil level too high.

Drain oil to proper level

Step 4. Engine too cold to ignite fuel properly.

Perform cold weather starting procedures. Close radiator shutters until the engine is operating at normal temperature.

DYNAMOTOR-WELDER

1. Dynamotor-Welder will Not Start when External Power Source Is Used.

Step 1. Power selector switch in wrong position.

Set selector switch to CITY position.

Step 2. Dynamotor switch defective or not properly actuated.

Actuate switch properly. Notify your supervisor if trouble still exists.

2. Dynamotor-Welder Overheats.

Ventilating air filters clogged.

Clean air filters (para. 3-16).

3. Dynamotor-Welder Rotates In Wrong Direction When External Power Source Is used.

External power lines connected wrong.

Remove power and interchange any two incoming power leads.

Table 3-2. Troubleshooting-Continued

---

**MALFUNCTION****TEST OR INSPECTION  
Corrective Action**

---

4. Dynamotor-Welder Will Not Deliver AC When Internal Power Source Is Used.

Power selector switch in OFF position.

Turn power selector switch to GEN.

**AIR COMPRESSOR**

1. Air Compressor Fails To Operate.

Step 1. Circuit breaker tripped.

Reset circuit breaker.

Step 2. Overload circuit in starter control box tripped.

Push reset button.

If problem still exists, notify your supervisor.

2. Air Compressor Fails To Build Up Pressure In Receiver Tank.

Step 1. Receiver tank draincock open.

Close draincock.

Step 2. Air hoses, lines or fittings leaking.

Tighten or replace hoses, couplings, or fittings.

Step 3. Inlet air filter clogged.

Clean or replace inlet air filter (para. 3-13 and 14-5).

3. Air Compressor Overheats.

Step 1. Check for blockage of air to fan wheel.

Move any foreign object that is blocking air passage. Use compressed air to remove any accumulation of dust or dirt.

Table 3-2. Troubleshooting-Continued

---

**MALFUNCTION**

**TEST OR INSPECTION**

**CORRECTIVE ACTION**

---

Step 2. Check for low oil level.

Fill to proper level.

Step 3. Check for clogged inlet filter.

Service or replace the inlet filter (para. 3-13 and 14-5).

4. Air Compressor Pumping Oil.

Step 1. Check for clogged inlet filter.

Service or replace the inlet filter (para. 3-13 and 14-5).

Step 2. Check for low oil level.

Fill to proper level.

5. Air Delivery Dropping.

Step 1. Check for clogged inlet filter.

Service or replace the inlet filter (para. 3-13 and 14-5) .

Step 2. Check for air leaks in piping.

Make a solution of soapy water and apply at fittings. If leak is found, notify your supervisor.

6. Excessive Starting and Stopping.

Step 1. Check the receiver drain.

Drain the receiver.

Step 2. Check for air leaks in piping.

Repeat step 2, of malfunction, paragraph 5.



Table 3-2. Troubleshooting-Continued

---

**MALFUNCTION**
**TEST OR INSPECTION****CORRECTIVE ACTION**


---

## BODY ENCLOSURE COMPONENTS

## 1. Side Lifting Hydraulic System Does Not Operate Properly.

Step 1. Control valve in wrong position.

Place control valve in proper position.

Step 2. Hydraulic oil supply low.

Fill hydraulic oil pump.

Step 3. Air in hydraulic system.

Notify your supervisor.

Section IV. OPERATOR/CREW MAINTENANCE

3-6. General. The instructions in this section are published for the information and guidance of the operator to maintain the shop set.

3-7. Batteries. Inspect and Service. Inspect batteries for cracked or broken cases, corrosion on the terminal posts, damaged or frayed cabled and loose connections. Check electrolyte level. Check more often under high temperature conditions.

3-8. Air Cleaner. Service. Loosen clamp screw and clamp and remove oil cup from the air cleaner. Clean oil cup with cleaning solvent and dry thoroughly. Fill oil cup to proper level. Install oil cup on air cleaner and secure with clamp and clamp screw.

3-9. Fuel Filter, Secondary. Service as follows:

WARNING

The diesel fuel used in the engine for the Dynamotor-Welder is combustible. Use caution when draining/filling fuel tank and working on the fuel system. Extinguish all smoking materials and do not allow sparks or open flame near the fuel tank and fuel system.

- a. Remove drain plug in filter housing and allow the fuel to drain into a suitable container.
- b. Remove the center screw to remove filter housing and gasket. Discard gasket.
- c. Remove element from housing and discard.
- d. Install new element into the housing.
- e. Install new gasket, housing and center screw. Tighten center screw securely.
- f. Install drain plug in the filter housing and tighten securely.

3-10. Starting Aid. Replace either unserviceable or empty ether tank as follows:

- a. Open ether tank bracket.
- b. Unscrew ether tank from solenoid valve and discard.
- c. Inspect threads of ether tank and solenoid valve for damage.
- d. Screw replacement tank into solenoid valve hand tight.

3-11. RADIATOR. Check coolant level in the radiator as follows:

WARNING

Always remove the radiator cap slowly to permit any pressure to escape.

- a. Remove the radiator cap.

**CAUTION**

Do not add coolant to an overheated engine unless it is running.

- b. Add coolant as required. Leave coolant level approximately 2 inches below the Overflow pipe to allow for expansion.

**3-12. LUBE OIL FILTER.** Service as follows:

- a. Thoroughly clean the oil filter housing and the surrounding area.
- b. Remove drain plug and allow the oil to drain into a suitable container.
- c. Remove the center bolt and sealing washer.
- d. Remove cap, gasket, spring and filter element from filter body. Discard gasket and filter element.
- e. Install new filter element into filter body.
- f. Install spring, new gasket and cap. Secure with washer and center bolt. Tighten center bolt securely to prevent leaks.
- g. Install drain plug and tighten securely.

**3-13 AIR COMPRESSOR INLET FILTER.** Service as follows:

**NOTE**

Use cleaning solvent Fed Spec P-D-680 for cleaning. Never use gasoline or similar fluids to clean the air inlet filter.

- a. Clean off the outside and mouth of the body. Remove one disc and four pads and remove the remaining disc.
- b. Wash inside of the filter body and wipe dry. Wash pads and disc and blow dry with compressed air.
- c. Inspect pads for excessive wear or loss of capacity to retain dust or dirt. Replace defective pads.
- d. Position disc in body, then stack four pads in body. Secure pads in body with the remaining disc.

### 3-14. BODY ENCLOSURE COMPONENTS.

- a. General. The enclosure includes a large hydraulically-operated door on each side of the body that opens to form an extended roof. Two lower doors on each side manually open downward to level position for use as extended floor area and as work benches. There is a personnel door at the rear of the body. The entire rear panel assembly is latched at the bottom and opens upwards to the horizontal position so that the tent frame and enclosure canvas may be used. The engine and dynamotor-welder housing has two doors on each side for access to the engine; a small door on the left side for access to the power receptacles and an inspection door on the street side retained by screws.
- b. Tent Frame.
  - (1) Removal. Loosen the straps that secure the tent frames to the roof of the van body and remove the tent frames.
  - (2) Cleaning and Inspection.
    - (a) Clean all parts with cleaning solvent and dry thoroughly.
    - (b) Inspect all parts for bends, cracks and other defects.
    - (c) Installation. Install the tent frames in their stowed position on top of the van body and secure with eight retaining straps.
- c. Canvas Walls, Roofing and Deflector.
  - (1) Removal. Remove the tent canvas from the shop set.

#### NOTE

Identify folded canvas so that they are refolded in the same way.

- (2) Cleaning and Inspection.
  - (a) Clean all parts with warm water and soap and dry thoroughly.
  - (b) Inspect the canvas for tears, open seams and improperly attached grommets and straps. Repair a defective canvas in accordance with FM#10-16.
  - (c) Installation. Fold and store the tent canvas in the shop set.
- d. Utility Ladders.
  - (1) Removal. Remove the ladder from its stowed position on the right side of the enclosure. Then remove the two ladders from their stored positions, inside the shop set on both sides at the rear.

- (2) Cleaning and Inspection.
  - (a) Clean ladders with cleaning solvent and dry thoroughly.
  - (b) Inspect for damage or defects and replace a defective ladder.
- (3) Installation. Install the utility ladders in their respective stowed positions as removed. Secure the front ladder with the retaining clamp and the two rear ladders with their retaining straps so they will remain in place while in transit.

### 3-15. SIDE LIFTING HYDRAULIC SYSTEM.

- a. General. Each side of the mobile shop is raised and lowered by an independent hydraulic Pump and cylinder. Each hydraulic pump supplies oil under pressure to the side lifting cylinder. The cylinder is lowered by releasing the control valve lever on the hydraulic pump. A flow control valve in the system provides a metered flow rate and controls the lowering speed of the cylinder when the control Valve lever is placed in the open or return position.
- b. Cleaning and Inspection of Hydraulic Pump.
  - (1) Clean external surface of the pump with a cloth dampened in cleaning solvent and wipe dry.
  - (2) Inspect for cracks, breaks, signs of leakage, and other damage.
  - (3) Remove the filler cap from the top of the pump and add fluid as necessary. Install and tighten filler cap.

### 3-16. DYNAMOTOR-WELDER. Cleaning and Inspection of ventilating Air Filters.

- a. Clean the air filters with Cleaning solvent and blow dry with low pressure compressed air.
- b. Inspect filters for breaks, holes, cracks and other defects.



## CHAPTER 4

### GENERAL MAINTENANCE INSTRUCTIONS

---

#### Section I. REPAIR PARTS, SPECIAL TOOLS, AND EQUIPMENT

- 4-1. SPECIAL TOOLS AND EQUIPMENT.** There are no special tools or support equipment required to perform any level of maintenance on the shop set.
- 4-2. REPAIR PARTS.** Repair parts are listed in the legends of the illustrations pertaining to the procedure being performed.
- 4-3. FABRICATED TOOLS AND EQUIPMENT.** No specially designed (fabricated) tools and equipment are required by maintenance personnel to support the shop set.
- 

#### Section II. SERVICE UPON RECEIPT OF MATERIAL

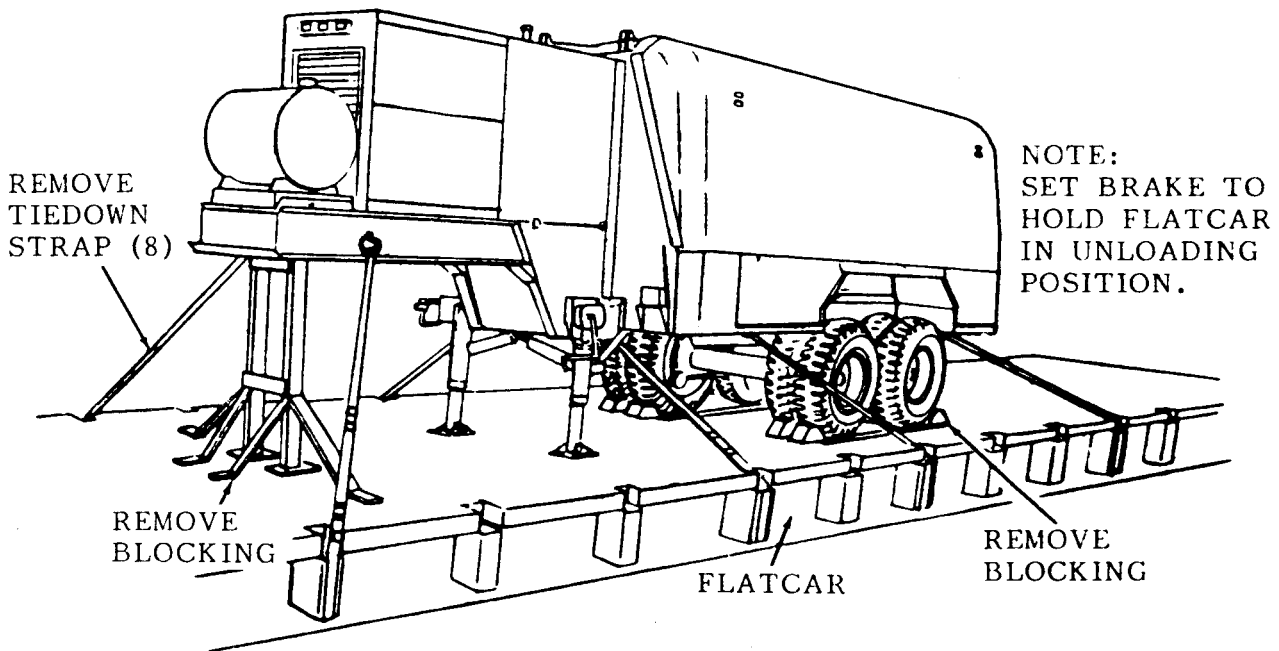
##### 4-4. UNLOADING EQUIPMENT.

- a. Shipment by Rail.
- (1) Refer to figure 4-1 and remove the blocking and tiedowns.
  - (2) Refer to figure 4-2 and construct a ramp for shop set removal.

- 4-5. UNPACKING EQUIPMENT.** The shop set equipment is shipped within the van body in boxes, drawers, or cabinets. Open the boxes, exercising caution in cutting the banding and removing the nails in order to prevent damage to the contents. Prepare the shop set for inspection or operation as outlined on DA Form 2258 (Depreservation Guide of Engineer Equipment) that has been prepared for the shop set.

##### 4-6. INSPECTING AND SEVICING EQUIPMENT.

- a. Perform daily preventive maintenance services (para. 4-13).
- b. Make a complete inspection of the shop set and the equipment, visually inspecting for loss or damage which may have occurred in shipment.
- c. Inspect the floor and other body members for dents, breaks, cracks, or loose or missing parts.
- d. Inspect the dynamotor-welder for breaks, dents, cracks, and loose or missing parts.
- e. Inspect the engine and components for loose or missing parts.
- f. Inspect the air compressor and components for defects and for loose or missing parts.

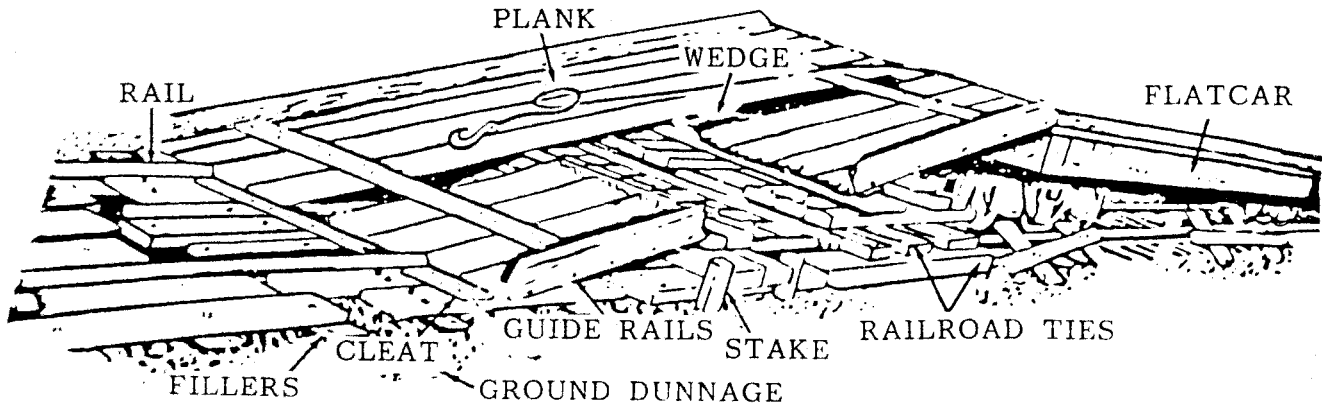


CAUTION: INSTALL WHEEL CHOCK (2) WHERE REQUIRED TO HOLD SHOP SET AS BLOCKING IS REMOVED.

Figure 4-1. Shop Set Blocking and Tiedown Instructions.



1. CONSTRUCT RAMP OF RAILROAD TIES, PLANKS, GUIDE RAILS, AND NECESSARY BLOCKS, CLEATS, STAKES, AND WEDGES.



NOTE: MAKE RAMP OF SUFFICIENT LENGTH TO PREVENT BOTTOMING OF UNDER-CHASSIS PARTS IN PASSING HUMP BETWEEN RAMP AND CAR.

NOTE: TWO DOUBLE PLANK RAMPS, CLEATED TOGETHER, MAY BE SUBSTITUTED FOR FULL WIDTH RAMP SHOWN.

2. BUILD APPROACH APRON TO RAIL LEVEL, USING GROUND DUNNAGE AND FILLERS.

Figure 4-2. Flatcar With Ramp In Place.

- g. Correct any deficiencies or refer them to direct support maintenance.
- h. Lubricate the shop set.
- i. Be sure the fuel tank is filled with the proper grade of diesel fuel.

#### 4-7. INSTALLATION OF SEPARATELY PACKED COMPONENTS.

**WARNING**

Do not smoke or use an open flame in the vicinity when servicing the batteries. Batteries generate hydrogen, a highly explosive gas.

- a. Refer to figure 4-3, and remove the batteries from the battery box.
- b. Remove the battery caps and fill each cell with electrolyte. Be sure the plates are covered with 3/8-inch of electrolyte. Refer to TM-9-6140-200-12.
- c. Refer to figure 4-3 and install the batteries in the battery box.

#### 4-8. INSTALLATION OF SETTING-UP INSTRUCTIONS.

- a. General. Power for operation of the shop set may come from either of two Sources : The shop set engine driving the dynamotor-welder or an external power source of 240 volts, 3-phase, 50- or 60-cycle power driving the dynamotor-welder. The external power source, if available and practical, will require setting-up procedures (para. 2-5b). The setting-up procedures for the shop set to use either of the two power sources will vary according to the amount of canvas erected and other factors, dependent primarily on the expected time duration of the installation, available power source, weather conditions and terrain.
- b. Location and Leveling. The shop set should be set up on clear, flat, level terrain. The landing gear must make firm, solid contact with the surface, and the wheels must be blocked in such a way as to keep the shop set from rolling. With the canvas erected, the area required by the shop set proper is approximately 40 x 25 ft. The location of the shop set must provide such additional cleared ground area as is required for adequate access to the shop set components from all sides. If possible, select a site that is protected from the elements (i.e. , dust, sand, and mud) .
- c. Opening Shop Set. Refer to figures 4-4 and 4-5 and open the shop set doors. Extend the hoist track as illustrated in figure 4-5. To open the top engine enclosure door, turn handle one-quarter turn clockwise and raise door until the two braces that support the door in the raised position automatically lock. Release the latch bolt on the inside of the lower door. This bolt is located near the top front of the lower door. To close the engine enclosure door, raise the lower door and secure the latch bolt. Release the top door by pres-

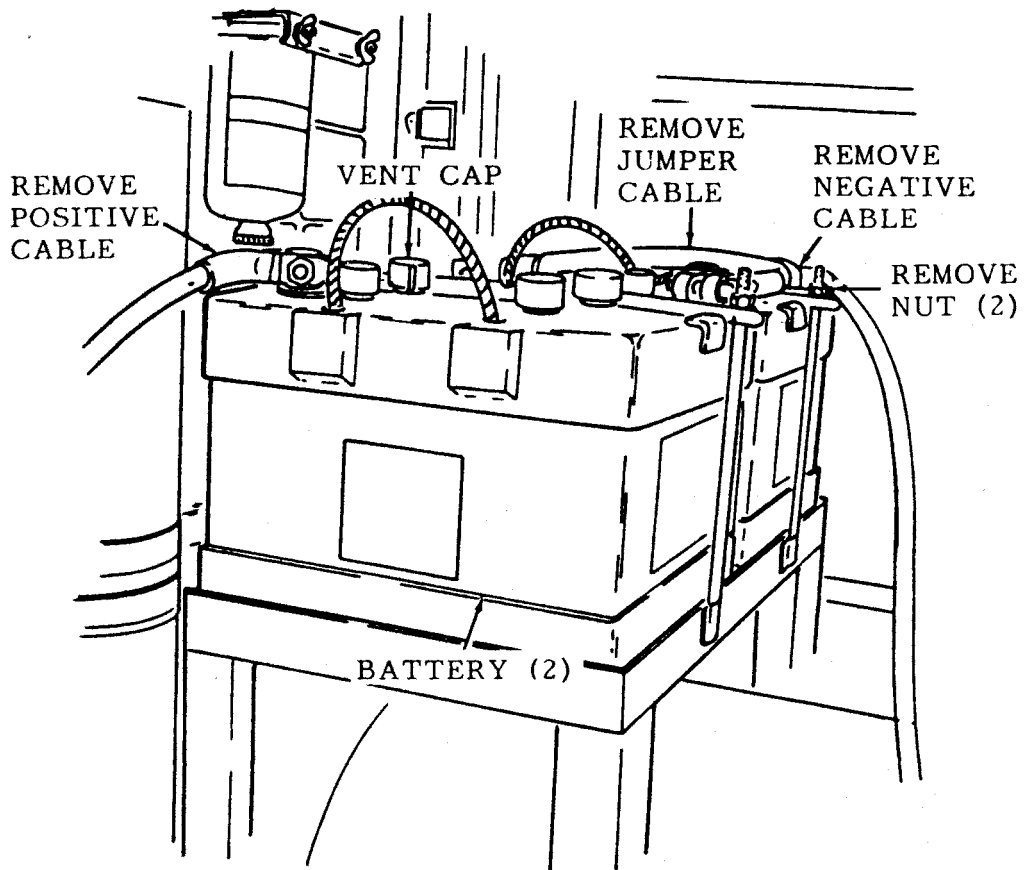


Figure 4-3. Batteries, Removal, Installation and Service.

sing the button located on each of the braces. Turn handle one-quarter turn counterclockwise to secure the door.

d. Erecting Tenting.

(1) Remove the straps that secure the tent frames to the roof of the shop set and remove the frames from the shop set.

(2) Refer to figures 4-6, 4-7, and 4-8 for instructions for assembling and erecting the tent frames and tenting. The tent frames and rear diagonal brace will fit either side of shop set.

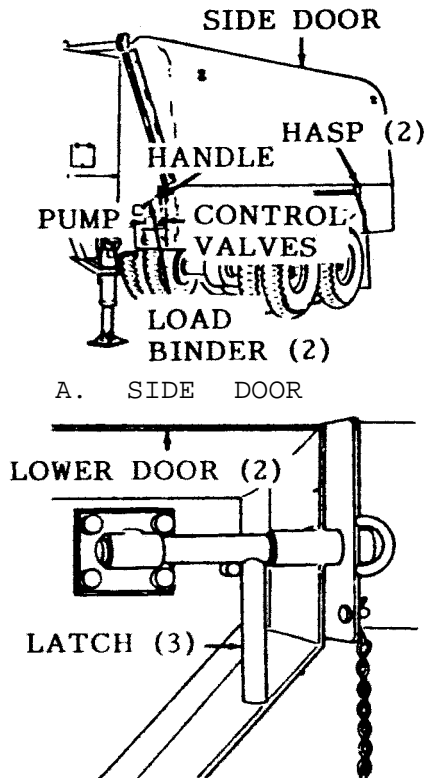
e. External Power Connection. Connect external power of 240-volt, 3-phase, 60 hertz input whenever it is available, as illustrated in figure 4-9. More detailed explanation of the connection of external power source is contained in paragraph 2-5b.

**WARNING**

Static electricity and leakage currents from electric equipment can build up in the shop set and cause injury or death to personnel unless the equipment is properly grounded.

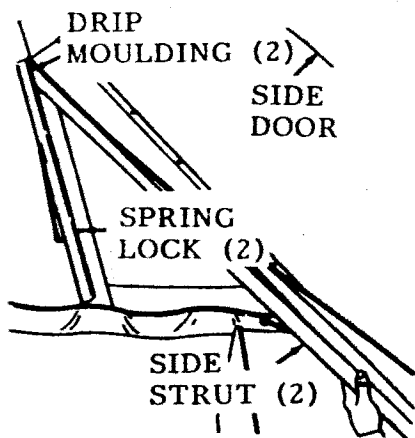
f. Grounding Shop Set. Drive a metal ground rod into the ground adjacent to the right side of the shop set. Attach a No. 6 bare copper wire between the shop set ground terminal (fig. 4-10) and the ground rod.

**4-9. EQUIPMENT CONVERSION.** The dynamotor-welder can be driven by the shop set engine or by an external power source. If an external power source is to be used connect the power source and set the frequency switch (fig. 4-11) to match the frequency of the incoming current, as shown by the frequency meter, either 50 or 60 hertz, and set the power selector switch on CITY. Conversion to shop set generated power is accomplished by stopping all shop set functions, turning switches to OFF and by removal of the external power source, setting the frequency switch (fig. 4-11) to 60 hertz, and the power selector switch to GENERATOR. The output from the receptacles on the control panel is either 120-volt, single-phase, at a maximum of 30 amperes, or 240-volts, single-phase, at a maximum of 10 amperes. To use either 120 or 240-volts from either GENERATOR or CITY power source, select the appropriate output receptacle or receptacles and the applicable power selector switch and frequency switch setting as indicated in figure 4-11.



A. SIDE DOOR

B. LATCH



C. STRUT

1. REMOVE ANY PADLOCKS OR LOCKING DEVICES FROM THE HASPS (2).
2. RELEASE LOAD BINDER (2).
3. REMOVE HANDLE FROM HANDLE RACK AND INSERT IN PUMP SOCKET. TURN CONTROL VALVE FULLY CLOCKWISE AND OPERATE PUMP TO RAISE DOORS TO EXTREME POSITION.
4. RELEASE LATCH (3) AND LOWER DOOR (2) .
5. REMOVE HANDLE, FROM PUMP SOCKET AND INSTALL IN PUMP RACK.
6. FREE SIDE STRUT (2) FROM SIDE DOOR AND POSITION AGAINST SPRING LOCK (2).
7. LOWER SIDE DOOR SO THAT SIDE STRUT (2) BEARS WEIGHT OF DOOR.

NOTE

TO RETRACT STRUT (2) REPEAT STEPS 3 AND 5.

TO LOWER SIDE DOOR, TURN CONTROL VALVE COUNTERCLOCKWISE ENOUGH TO ALLOW DOOR TO DROP.

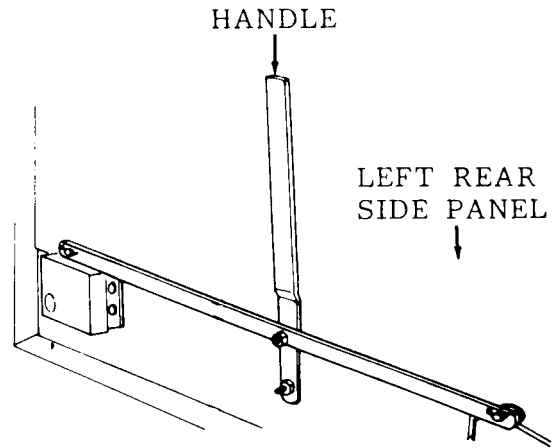
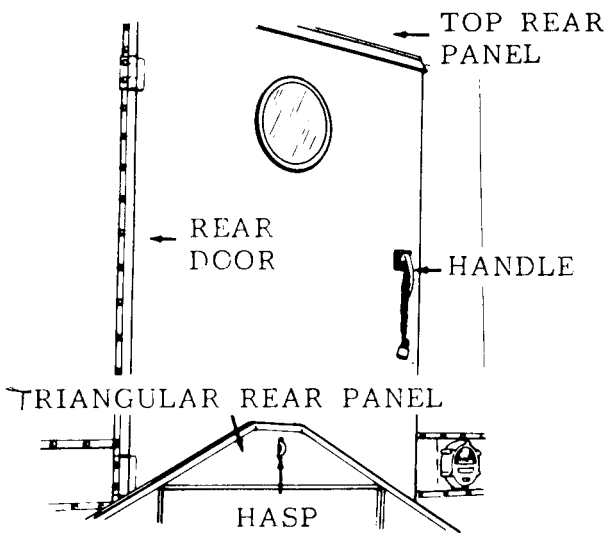
NOTE

RAISE AND LOWER OTHER SIDE DOOR IN SIMILAR MANNER.

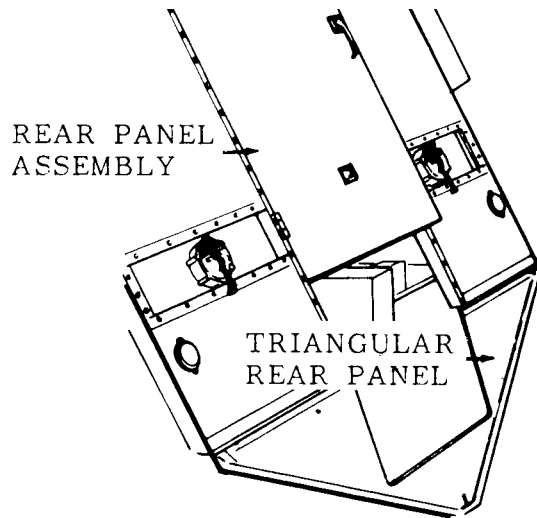
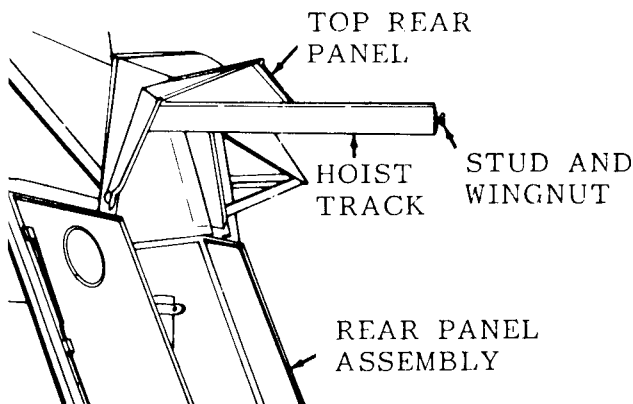
NOTE

BEFORE FULLY LOWERING SIDE DOOR , SECURE SIDE STRUT (2) IN RETRACTED POSITION ON SIDE DOOR.

Figure 4-4. Raising and Lowering Shop Set Side Doors.

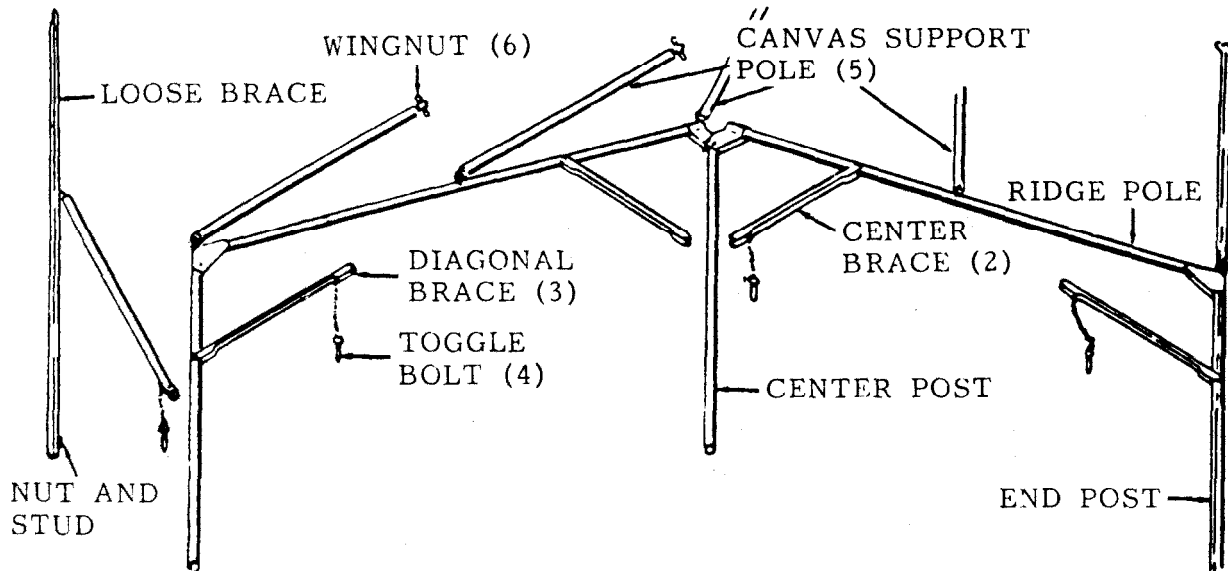


1. RAISE SIDE DOORS (FIG. 4-4).
2. REMOVE ANY LOCKING DEVICE, OPEN HASP, AND LOWER TRIANGULAR REAR PANEL.
3. TURN HANDLE AND OPEN REAR DOOR.
4. LIFT REAR DOOR FROM HINGE AND REMOVE.
5. MOVE HANDLE TOWARD THE SIDE OF SHOP BODY TO RELEASE THE LATCHES RETIANING THE BOTTOM OF THE LEFT AND RIGHT REAR PANELS.



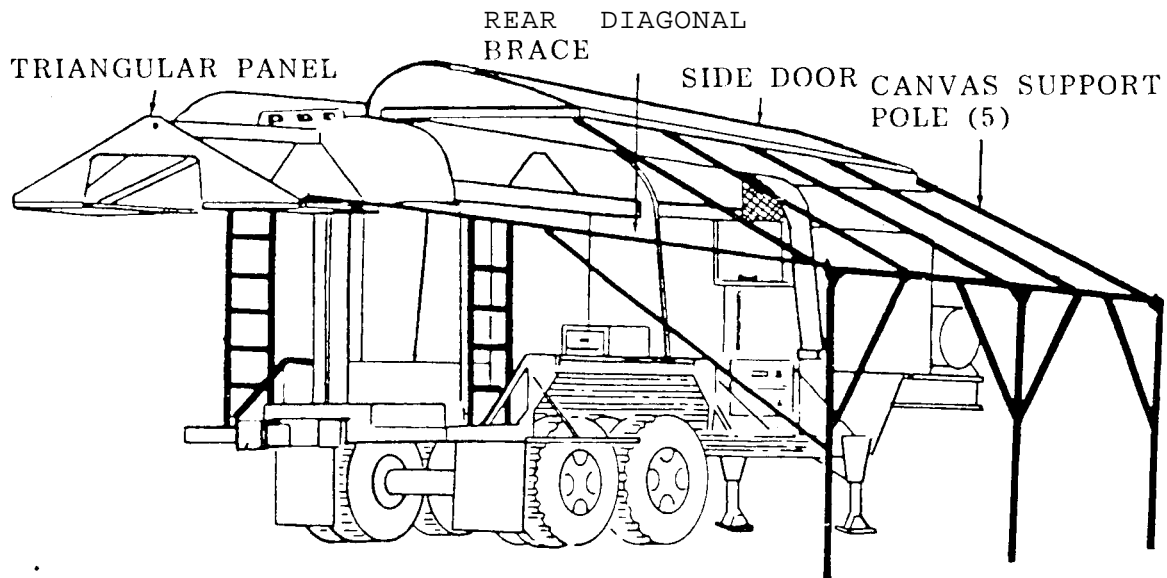
6. RAISE TOP REAR PANEL AND PULL HOIST TRACK OUT TO ITS FULLY EXTENDED POSITION .
7. RAISE REAR PANEL ASSEMBLY AND HOOK TRIANGULAR REAR PANEL OVER STUD AT THE EXTENDED END OF HOIST TRACK, AND SECURE WITH WING NUT.

Figure 4-5. Opening Shop Set Rear Doors and Panels.



- STEP 1 . LAY OUT TENT FRAME SO THAT HINGED RIDGE POLE IS STRAIGHT.
- STEP 2. ATTACH THE SHORT SECTION OF THE REAR DIAGONAL BRACE TO THE LOWER PART OF THE REAR END POST, AND SECURE WITH THE LOCKING PIN ATTACHED TO THE BRACE. ATTACH THE LONG SECTION OF THE REAR DIAGONAL BRACE TO THE STUD ON TOP OF THE REAR END POST AND SECURE WITH WING NUT.
- STEP 3. ATTACH THE LOOSE ENDS OF THE TWO END DIAGONAL BRACES TO THE RIDGE POLE AND SECURE WITH THE TWO LOCKING PINS ATTACHED TO THE BRACES. ATTACH THE LOOSE ENDS OF THE TWO CENTER DIAGONAL BRACES TO THE CENTER POST AND SECURE WITH THE ONE LOCKING PIN THAT IS ATTACHED TO ONE DIAGONAL BRACE.
- STEP 4. THE TENT FRAME FOR BOTH SIDES ARE ASSEMBLED AS SHOWN IN STEPS 1, 2, AND 3 ABOVE. THE REAR DIAGONAL BRACE MUST ALWAYS BE INSTALLED ON THE REAR OF TENT FRAME.

Figure 4-6. Laying Out Tent Framing.

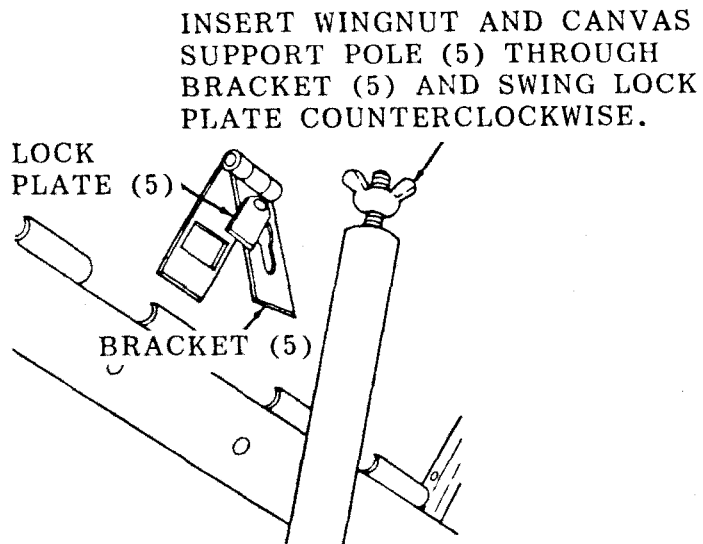


A. INSTALLING TENT FRAME.

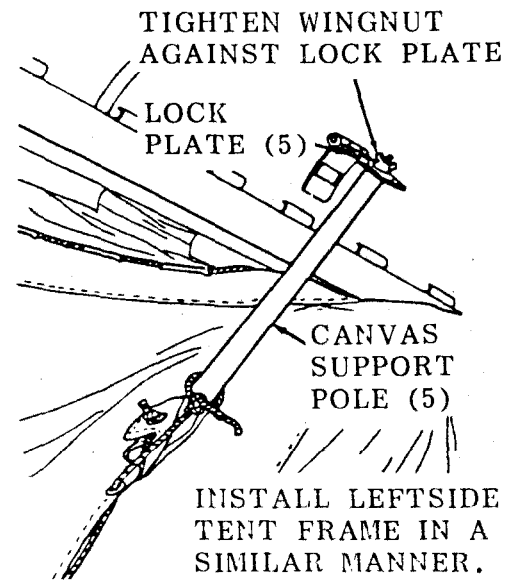
1. INSTALL, AND SECURE CANVAS SUPPORT POLE (5) AS SHOWN IN FIG. 4-7 SHEET 2.
2. INSTALL STUD OF REAR DIAGONAL, BRACE IN RIGHT SIDE REAR TRIANGULAR PANEL AND SECURE WITH WINGNUT.

Figure 4-7. Erecting Tent Framing (Sheet 1 of 2).



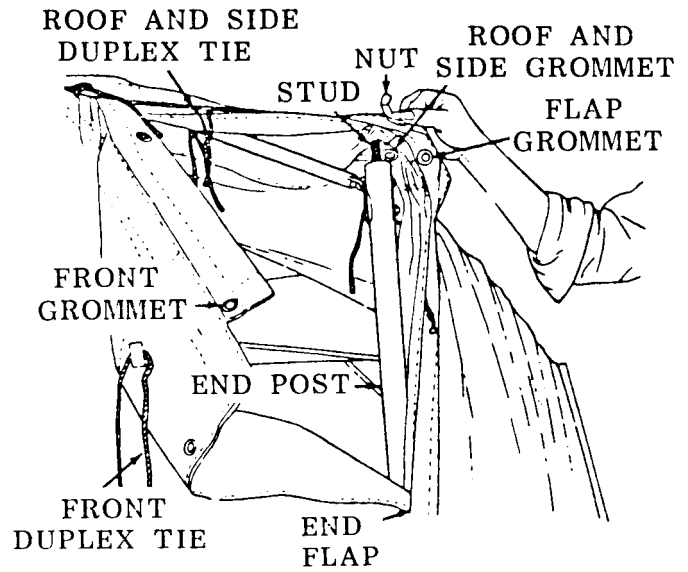
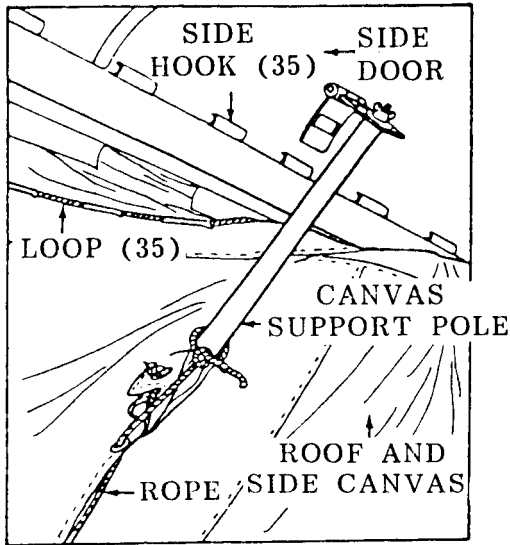


B. INSTALLING CANVAS SUPPORT POLE (5).



C. SECURING CANVAS SUPPORT POLE (5).

Figure 4-7. Erecting Tent Framing (Sheet 2 of 2).



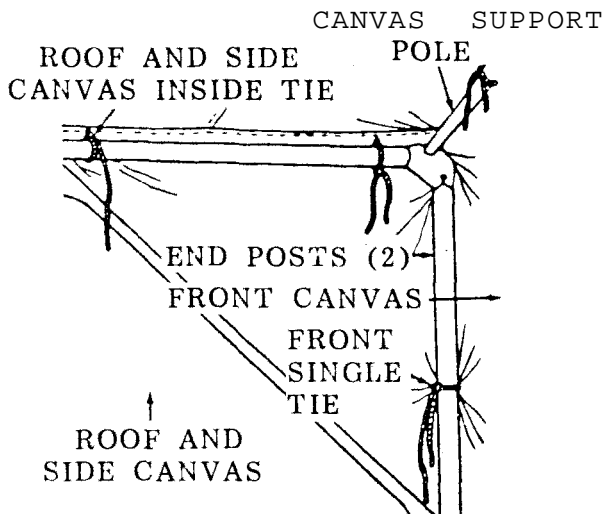
A. RAISING ROOF AND SIDE CANVAS.

1. OPEN LEFT ROOF AND SIDE CANVAS WITH MARKED SIDE AT TOP AND LOOP (35) AWAY FROM TENT FRAME.
2. PULL LOOP EDGE UP AND OVER TENT FRAME AND INSTALL LOOP (35) ON SIDE HOOK (35) ON SIDE DOOR. KEEP MARKED SIDE OF CANVAS INWARD.
3. POSITION A FLAP PAIR (3) AROUND CENTER CANVAS SUPPORT POLE AND SECURE BY LACING ROPE THROUGH GROMMETS OF EACH FLAP PAIR.

B. SECURING ROOF AND SIDE CANVAS TO END POST (2).

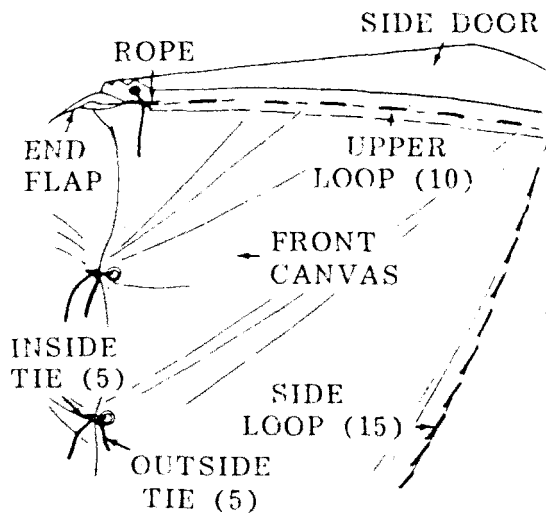
1. REMOVE NUT FROM STUD OF FRONT END POST, FOLD BACK END FLAP OF ROOF AND SIDE CANVAS, AND INSTALL ROOF AND SIDE GROMMET ON STUD. LOOSELY INSTALL NUT ON STUD.
2. INSTALL ROOF AND SIDE GROMMET AT BACK ON REAR END POST IN SIMILAR MANNER.

Figure 4-8. Erecting Tenting (Sheet 1 of 3).



C. SECURING ROOF AND SIDE CANVAS INSIDE TIES.

1. SECURE ROOF AND SIDE CANVAS INSIDE TIES TO CANVAS SUPPORT POLE (5), AND TO END POST (2).



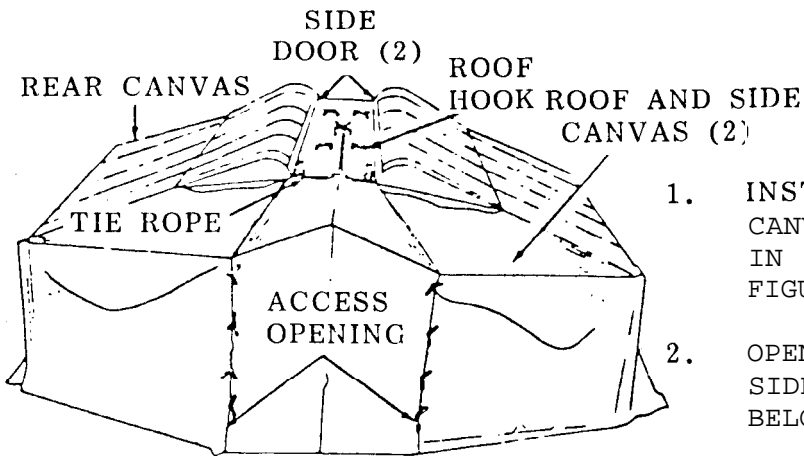
D. INSTALLING FRONT CANVAS.

1. OPEN LEFT FRONT CANVAS AND HANG MARKED SIDE INWARD BY INSTALLING UPPER LOOP (10) ON FRONT HOOKS OF SIDE DOOR. INSTALL SIDE LOOP (15) ON RETAINING HOOKS.
2. REMOVE WING NUT FROM STUD AT TOP OF FRONT END POST AND INSTALL THE FRONT PANEL CORNER GROMMET ON THE STUD ON TOP OF THE END POST AND SECURE LOOSELY WITH WINGNUT. PULL ROOF AND SIDE DUPLEX TIES THROUGH MATING FRONT GROMMET AND SECURE WITH KNOT. PULL END FLAP OVER TIES AND END POST AND SECURE BY PULLING FRONT DUPLEX TIES THROUGH FLAP GROMMETS AND KNOTTING.
3. SECURE END FLAP TO FRONT CANVAS WITH ROPE.

4. REFER TO STEP C AND SECURE FRONT SINGLE TIES AND ROOF AND SIDE CANVAS INSIDE TIES AROUND AND TO FRONT END POST.
5. FASTEN INSIDE THE (5) AND OUTSIDE (5) AT ACCESS OPENING TO CLOSE THE OPENING.

NOTE: ACCESS OPENING HAS A FLAP FOR BLACKOUT USE. BE SURE TO FASTEN BOTH INSIDE AND OUTSIDE TIES.

Figure 4-8. Erecting Tenting (Sheet 2 of 3).

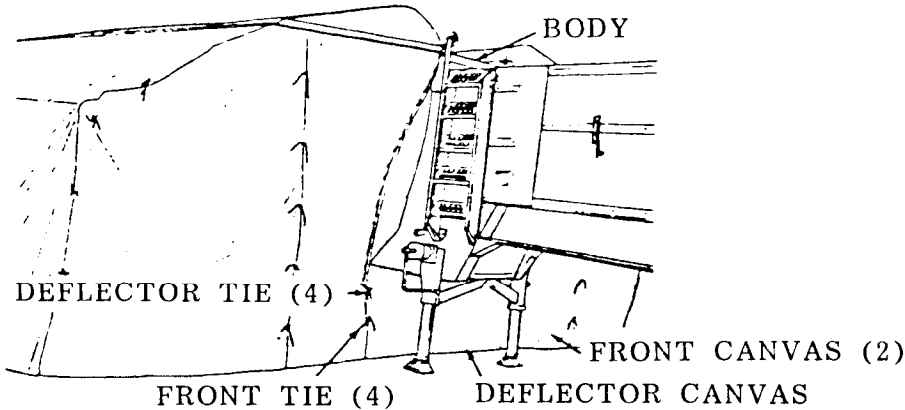


1. INSTALL RIGHT ROOF AND SIDE CANVAS AND RIGHT FRONT CANVAS IN SIMILAR MANNER AS SHOWN IN FIGURE 4-8 (1) AND 4-8 (2).
2. OPEN REAR CANVAS WITH MARKED SIDE DOWN AND CENTER TIE ROPE BELOW EXTENDED HOIST RAIL.
3. RAISE REAR CANVAS UP AND OVER RAIL AND TRIANGULAR PANEL. FASTEN TIE ROPE TO ROOF HOOK.

E. INSTALLING AND SECURING REAR CANVAS.

4. INSTALL REAR CANVAS ON SIDE DOOR (2) AND END POST (2). SECURE DOOR (2) AND END POST (2). SECURE REAR CANVAS TO ROOF AND SIDE CANVAS (2) AND CLOSE REAR ACCESS OPENING (2) IN SIMILAR MANNER AS SHOWN IN FIG. 4-8 (2).

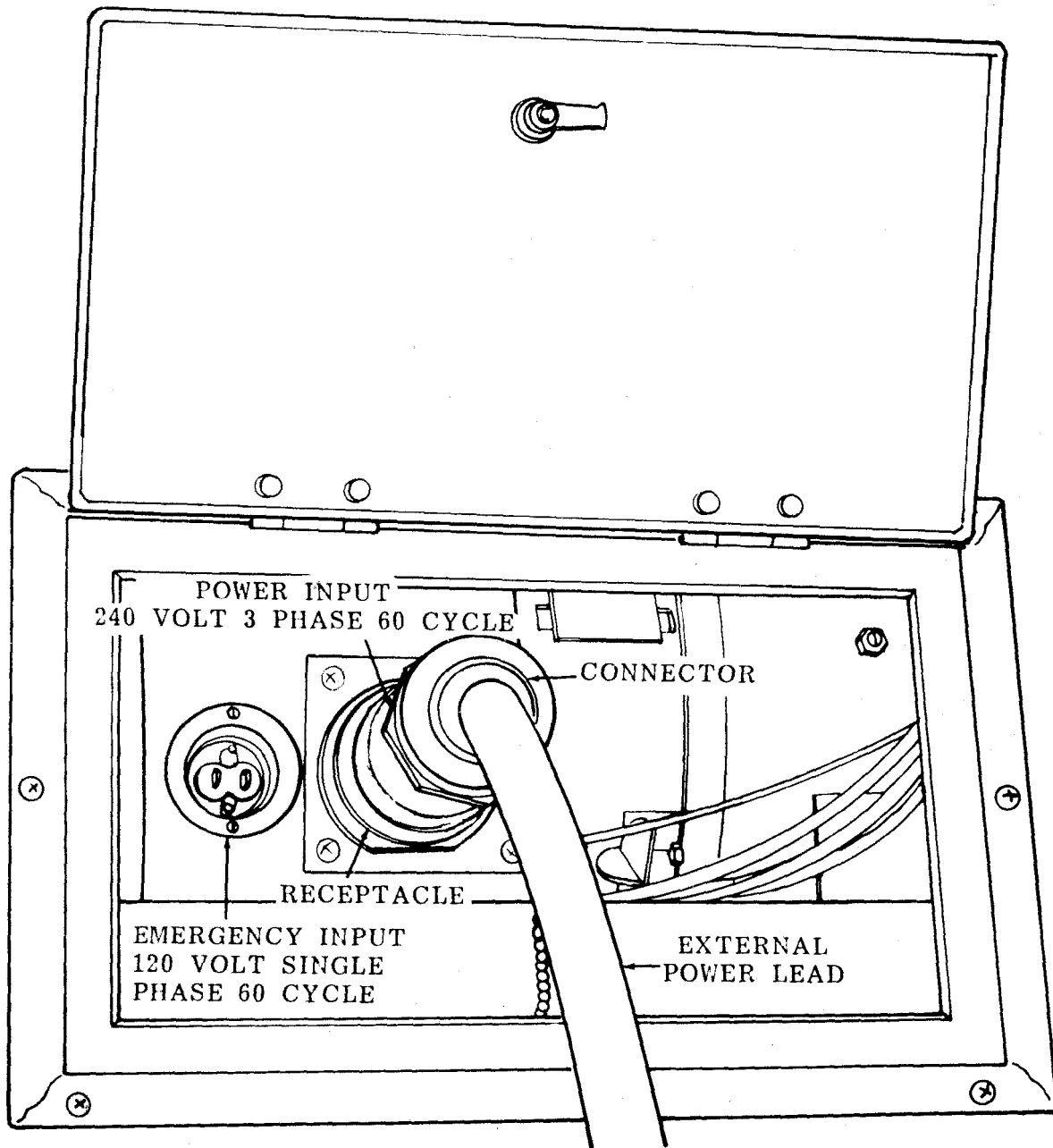
CAUTION: EXERCISE CARE TO AVOID TEARING REAR CANVAS WHEN RAISING.



F. INSTALLING DEFLECTOR CANVAS.

1. SECURE DEFLECTOR CANVAS TO FRONT CANVAS (2) BY SECURING FRONT TIE (4) TO DEFLECTOR TIE (4).
2. INSTALL GROMMET (4) AT TOP DEFLECTOR CANVAS ON HOOKS WELDED TO UNDERSIDE OF BODY.

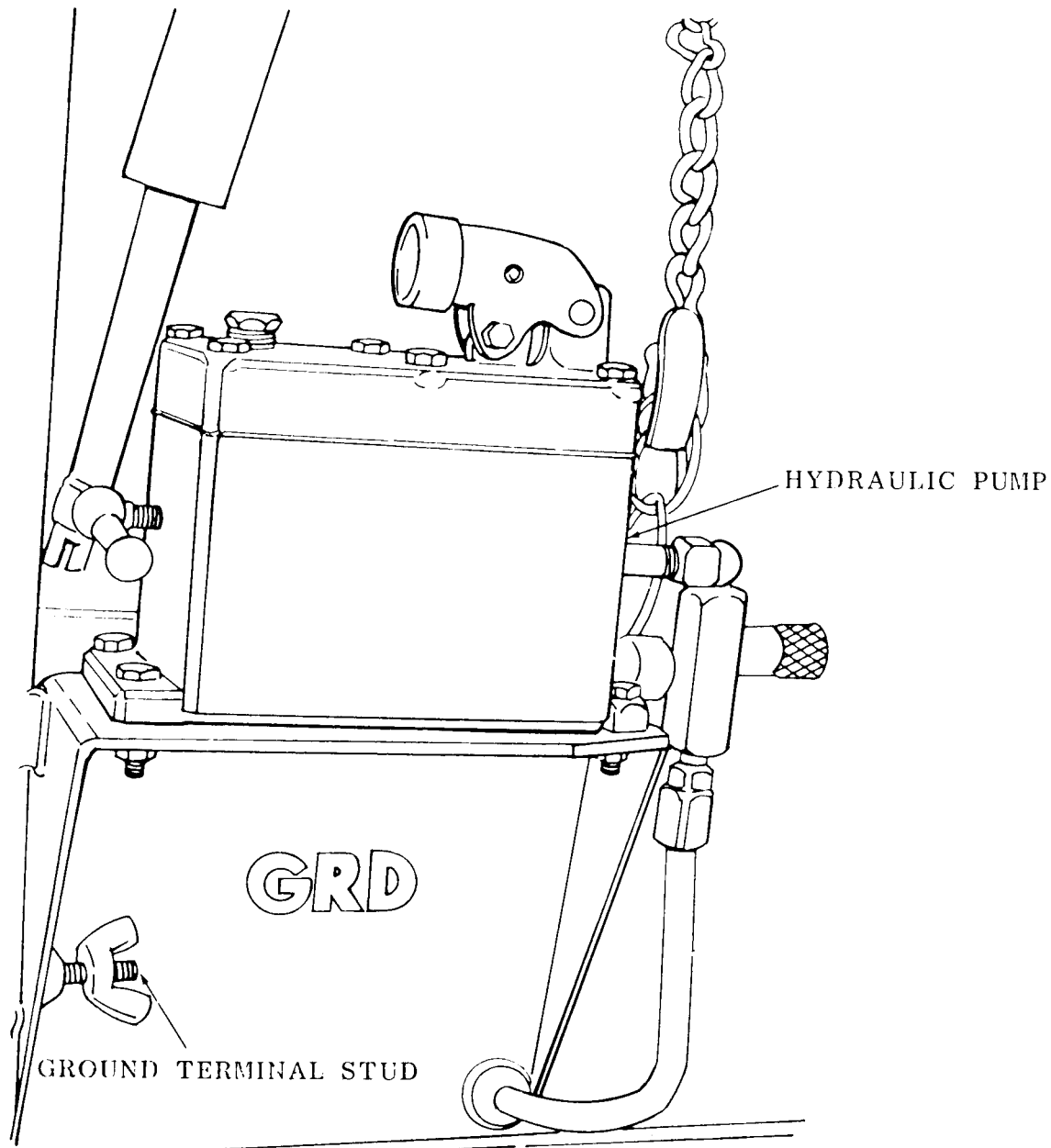
Figure 4-8. Erecting Tenting (Sheet 3 of 3).



NOTE: WHEN USING EXTERNAL POWER CHECK ROTATION OF GRINDER BEFORE USING OTHER EQUIPMENT.

CAUTION: REFER TO PARAGRAPH 2-5b AND SET ALL ELECTRICAL SYSTEMS SWITCHES TO "OFF" BEFORE INSERTING EXTERNAL POWER .

Figure 4-9. External Power Supply, Disconnection and Reconnection.



1. DRIVE A METAL GROUND ROD FULLY INTO GROUND ADJACENT TO SHOP SET.
2. ATTACH A NUMBER 6 BARE COPPER WIRE TO GROUND TERMINAL STUD AND THE GROUND ROD.

**WARNING**

INJURY OR DEATH CAN RESULT IF SHOP SET IS NOT PROPERLY GROUNDED.

Figure 4-10. Grounding the Shop Set.

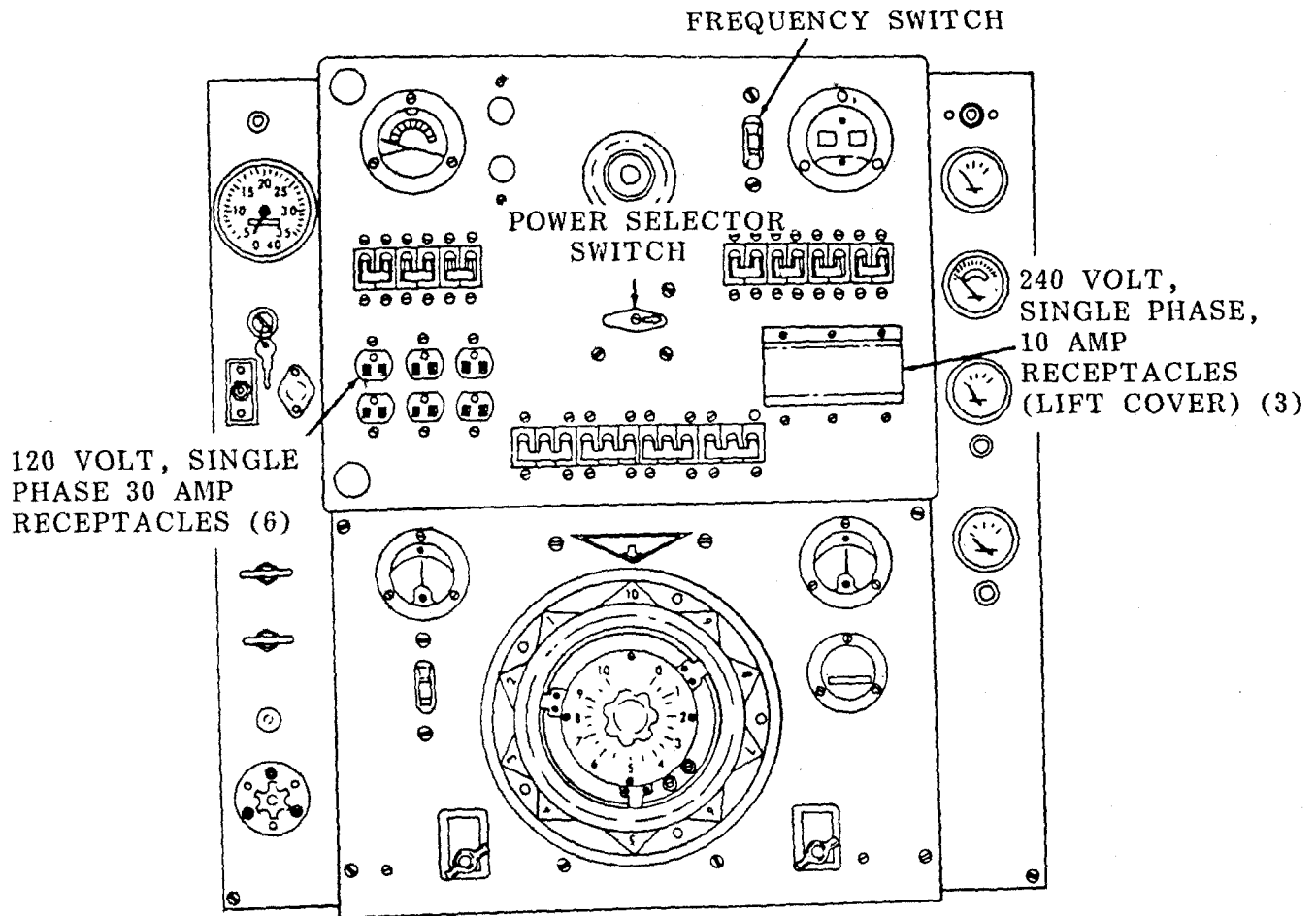


Figure 4-11. Voltage and Frequency Conversion.

### Section III. MOVEMENT TO A NEW WORKSITE

#### 4-10. DISMANTLING FOR MOVEMENT.

- a. Disconnect the external power source, if used.
- b. Dismantle the canvas tenting (figs. 4-6, 4-7, and 4-8).
- c. Disconnect welding cables and stow in the proper compartments.
- d. Secure all portable equipments and stow in proper place and latch and/or lock all drawers.

#### NOTE

Do not change loading plan (Appendix C) .

- e. Close the shop set (figs. 4-4 and 4-5) .
- f. Remove the ground rod.
- g. If the shop set is to be moved by rail, reverse the procedure described in paragraph 4-4.

#### 4-11. REINSTALLATION AFTER MOVEMENT. Refer to paragraph 4-8 and set up the shop set.

---

### Section IV. LUBRICATION

#### 4-12. GENERAL LUBRICATION INFORMATION..

- a. This section contains lubrication instructions.
- b. Care of Lubricants. Store all lubricants in closed containers and keep them in a clean dry area, away from heat. Keep all lubrication equipment clean and ready for use.
- c. Cleaning.
  - (1) Wipe area around the points of lubrication before and after applying lubricant. Remove excess lubricant after lubrication.
  - (2) Always keep shop set free of spilled lubricant.
- d. Operation After Lubrication. After each engine oil change, start the engine and check the oil pressure. If oil pressure is not indicated within 30 seconds, stop the engine and check the oil level. Add oil if necessary. Inspect the oil filter, oil lines , and connections for leaks.



---

## Section V. PREVENTIVE MAINTENANCE CHECKS AND SERVICES

- 4-13. GENERAL.** To insure that the shop set is ready for operation at all times, it must be inspected systematically so that defects may be discovered and corrected before they result in serious damage or failure. The necessary preventive maintenance checks and services to be performed are listed in table 4-1. Defects discovered during operation of the unit will be noted for future correction to be made as soon as operation has ceased. Stop operation immediately if a deficiency is noted which would damage the equipment if operation were continued. All deficiencies and short comings will be recorded, together with the corrective action taken on DA Form 2404 (Equipment Inspection and Maintenance Worksheet) at the earliest possible opportunity.
- 4-14. PREVENTIVE MAINTENANCE CHECKS AND SERVICES.** Refer to table 4-1 for a list of checks and services.

---

## Section VI. TROUBLESHOOTING

- 4-15. GENERAL.**
- a. This section contains troubleshooting information for locating and correcting most of the operating troubles which may develop in the shop set. Each malfunction for an individual component, unit, or system is followed by a list of tests or inspections which will help you to determine corrective actions to take. You should perform the tests/inspections and corrective actions in the order listed.
  - b. This manual cannot list all malfunctions that may occur, nor all tests or inspections and corrective actions. If a malfunction is not listed or is not corrected by listed corrective actions, notify your supervisor.
  - c. The table lists the common malfunctions which you may find during the operation or maintenance of the shop set or its components. You should perform the tests/inspections and corrective actions in the order listed.
- 4-16. TROUBLESHOOTING.** Refer to table 4-2 for troubleshooting information.

### NOTE

Before you use this table, be sure you have performed all applicable operating checks.

**Table 4-1. Quarterly Preventive Maintenance Checks and Services**

Sequence No.	Item to be Inspected Procedure
1	<p>Radiator</p> <p>Proper coolant level is 2-inches below filler neck. Replace cracked or frayed hose (para. 9-4). Remove obstructions in air passages. Tighten all mounting or leaking connections. Correct cap pressure rating is seven pounds. Replace a defective radiator (para. 9-2).</p>
2	<p>Engine Fan V-Belts</p> <p>Adjust to proper deflection of 1/2-inch midway between fan and crankshaft pulley. Replace worn or defective belts in sets (para. 9-5).</p>
3	<p>Fuel Filters</p> <p>Drain sediment. Tighten loose mounting and connections.</p>
4	<p>Batteries</p> <p>Remove corrosion. Inspect for cracks and leaks. Tighten loose cables and mounting. Fill to 3/8-inch above plates, Clean vent holes. In freezing weather run engine a minimum of 1 hour after adding distilled water.</p>
5	<p>Oil Level Gage</p> <p>Add oil as indicated by level gage.</p>
6	<p>Dynamotor-Welder Ventilating Air Filters</p> <p>Clean or replace dirty or defective air filters (paras. 3-2 and 3-16).</p>

**Table 4-1. Quaterly Preventive Maintenance Checks and Services-Continued**

Sequence No.	Item to be Inspected Procedure
7	<p>Welder Controls and Instruments</p> <p>Inspect for damage and loose mounting. With unit operating check for proper operation. Normal operating readings are as follows:</p> <p>AC Voltmeter: . 240-volts.                      Frequency Meter: 50-60 hertz.                      DC Voltmeter: Terminal voltage.                      DC Ammeter: Indicates applied load current not to exceed 300 amps.                      Replace defective controls or instruments.</p>
8	<p>Engine Controls and Instruments</p> <p>Inspect for damage and loose mounting. With unit operating check for proper operation. Normal readings are as follows:</p> <p>Water temperature gage: 180-195°F.                      Oil pressure gage: 40-60 psi.                      Battery alternator indicator: Pointer to green.                      Tachometer: 1,800 rpm at 60-hertz.                      1,500 rpm at 50-hertz.                      Replace defective controls or instruments.</p>
9	<p>Circuit Breakers</p> <p>Inspect for defective circuit breaker. Replace defective circuit breaker.</p>
10	<p>Air Pressure Gage</p> <p>Check for normal gage reading of 125-150 psi.                      Clean safety relief valve and adjust to open at 175 psi as necessary.</p>

Table 4-1. Quarterly Preventive Maintenance Checks and Services - Continued

Sequence No.	Item to be Inspected Procedure
11	<p>Air Receiver</p> <p>Drain condensate. Tighten loose mounting and connections.</p>
12	<p>Intercooler</p> <p>Clean dirt from fins. Straighten bent fins.</p>
13	<p>Lathe Motor V-Belts</p> <p>Check for worn, frayed, or cracked belts. Adjust belts to 1/2-inch deflection midway between motor and lathe pulleys. Replace worn or defective belts in sets of 3.</p>
14	<p>Lights and Lenses</p> <p>Replace burned out lamps. Replace cracked lenses.</p>
15	<p>Airbrake System</p> <p>Drain condensate from air tank. Replace worn or frayed hose. Adjust brakes as necessary.</p>
16	<p>Tires and Wheels</p> <p>Check for cut or badly worn tires. Proper pressure is 75 lbs. Replace damaged or badly worn tires (para. 19-4). Replace a damaged wheel (para. 19-4).</p>
17	<p>Hydraulic Pumps</p> <p>Add oil as required. Replace leaking or defective pumps (para. 17-3).</p>

**Table 4-1.** Quarterly Preventive Maintenance Checks and Services - Continued

Sequence No.	Item to be inspected Procedure
18	Fire Extinguisher  Check for broken seal.
19	Grounding  Check for proper ground.
20	Fuel Tank  Add fuel as required. Tighten loose mounting. Clean vent cap, replace defective cap gasket. Replace a leaking or defective fuel tank that cannot be repaired (para. 8-2).
21	Operation  During operation, observe for any unusual noise or vibration.
22	Adjustments  Stop operational test, disconnect power source, and make necessary adjustments.

Table 4-2. Troubleshooting

---

**MALFUNCTION**

**TEST OR INSPECTION**

**CORRECTIVE ACTION**

---

ENGINE

1. Engine Fails to Crank.

Step 1. Check for dead or damaged battery.

If battery is dead or damaged, recharge or replace battery as required (para. 7-2).

If battery is not dead or damaged, proceed to step 2.

Step 2. Check for bad starter solenoid (para. 7-3).

If starter solenoid is bad, replace starter solenoid.

If starter solenoid is not bad, proceed to step 3.

Step 3. Check for bad starter.

If starter is bad, replace starter (para. 7-3).

2. Engine Cranks but Fails to Start.

Step 1. Check for dirty or clogged fuel filter.

If fuel filter is clogged or dirty, clean (para. 3-9) or replace filter as required (paras. 8-5 and 8-8).

If fuel filter is not clogged or dirty, proceed to step 2.

Step 2. Check for incorrectly timed fuel pump.

If fuel injection pump is incorrectly timed, retime fuel pump (para. 8-6).

If fuel injection pump is properly timed, proceed to step 3.

Step 3. Check for faulty fuel injection pump.

If fuel injection pump is faulty, replace pump (para. 8-6).

If fuel pump is not faulty, proceed to step 4.

Table 4-2. Troubleshooting-Continued

**MALFUNCTION****TEST OR INSPECTION****CORRECTIVE ACTION**

- 
- Step 4. Check for damaged fuel nozzle assembly.
- If fuel nozzle assembly is damaged, replace assembly (para. 8-7).
- If fuel nozzles are not damaged, check for damaged or clogged fuel lines.
3. Engine Misses or Runs Erratically.
- Step 1. Check for restricted or damaged exhaust system.
- If exhaust system is damaged or restricted, replace damaged exhaust or clear restriction.
- If exhaust is not restricted or damaged, proceed to step 2.
- Step 2. Check for damaged fuel nozzle assembly.
- If fuel nozzle assembly is damaged, replace fuel nozzle assembly (para. 8-7).
- If fuel nozzle assembly is not damaged, proceed to step 3.
- Step 3. Check for damaged fuel pump.
- If fuel pump is damaged, replace fuel pump (para. 8-6).
- If fuel pump is not damaged, proceed to step 4.
- Step 4. Remove head and check for damaged head gasket (para. 12-4).
- If head gasket is damaged, replace head gasket.
- If head gasket is not damaged, proceed to step 5.
- Step 5. Check for damaged valves or pistons.
- If valves or pistons are damaged, replace damaged parts (paras. 12-4 and 12-11).
- If valves or pistons are not damaged, check for damaged head or other engine parts.
4. Engine Lacks Power.
- Step 1. Check for damaged fuel nozzle assembly.
- If fuel nozzle assembly is damaged, replace fuel nozzle assembly (para. 8-7).

Table 4-2. Troubleshooting-Continued

**MALFUNCTION**

**TEST OR INSPECTION**

**CORRECTIVE ACTION**

---

<p>5. Engine Will Not Idle Smoothly.</p>	<p>If fuel nozzle assembly is not damaged, proceed to step 2.</p> <p>Step 2. Check for damaged fuel injection pump.</p> <p>If fuel injection pump is damaged, replace pump (para. 8-6).</p> <p>If fuel injection pump is not damaged, proceed to step 3.</p> <p>Step 3. Check for damaged head gasket.</p> <p>If head gasket is damaged, replace head gasket (para. 12-4) .</p> <p>If head gasket is not damaged, proceed to step 4.</p> <p>Step 4. Check for damaged valves or valve spring.</p> <p>If valves or valve springs are damaged, replace damaged part.</p> <p>If valves or valve springs are not damaged, check for damaged pistons or piston rings.</p>
<p>Step 1. Check for damaged fuel nozzle assembly.</p> <p>If fuel nozzle assembly is damaged, replace fuel nozzle assembly (para. 8-7).</p> <p>If fuel nozzle assembly is not damaged, proceed to step 2.</p> <p>Step 2. Check for damaged fuel injection pump.</p> <p>If fuel injection pump is damaged, replace fuel injection pump (para. 8-6).</p> <p>If fuel injection pump is not damaged, proceed to step 3.</p> <p>Step 3. Check for damaged valves or damaged valve springs.</p> <p>If valves or valve springs are damaged, replace as required (para. 12-4).</p> <p>If valves or valve springs are not damaged, check camshaft.</p>	



Table 4-2. Troubleshooting-Continued

**MALFUNCTION****TEST OR INSPECTION****CORRECTIVE ACTION**

## 6. Engine Overheats.

Step 1. Check shutter control for proper operation.

If shutter control is working improperly, clean, adjust or replace damaged components as required.

If shutter works properly, proceed to step 2.

Step 2. Check radiator for damage or clogging.

If radiator is damaged, replace or repair radiator as required (para. 9-2).

If radiator is clogged, unclog radiator (para. 9-3).

If radiator is not clogged or damaged, proceed to step 3.

Step 3. Check water pump for damage.

If water pump is damaged, replace or repair as required (para. 9-6).

If water pump is not damaged, check oil pump for damage.

## 7. Engine Knocks.

Step 1. Check valve clearance.

If valves are out of adjustment, adjust valves (para. 12-4).

If valves are not out of adjustment, proceed to step 2.

Step 2. Check the fuel injection nozzles for damage.

If the fuel injection nozzles are damaged, replace the damaged nozzles (para. 8-7).

If the nozzles are not damaged, proceed to step 3.

Step 3. Check the flywheel for damage or looseness.

If the flywheel is damaged, replace flywheel (para. 12-2).

If the flywheel is loose, tighten the flywheel.

If the flywheel is neither loose nor damaged, proceed to step 4.

Table 4-2. Troubleshooting-Continued

**MALFUNCTION**

**TEST OR INSPECTION**

**CORRECTIVE ACTION**

Step 4. Check fuel injection pump timing.

If fuel injection pump needs timed, retime fuel pump (para. 8-6).

If fuel injection pump is in time, proceed to step 5.

Step 5. Check for damaged timing gears (para. 12-3).

If timing gears are damaged, replace damaged parts.

If timing gears are not damaged, proceed to step 6.

Step 6. Check for damaged or worn connecting rod bearings and wrist pins.

If connecting rod bearings or wrist pins are damaged or worn, replace the defective parts (para. 12-10).

If connecting rod bearings or wrist pins are not defective, check main bearings.

8. Engine Exhaust Smoke Excessive.

Step 1. Check for damaged fuel injection nozzles.

If fuel injection nozzles are damaged, replace nozzles (para. 8-7).

If fuel injection nozzles are dirty, or out of adjustment, clean and adjust nozzles as required (para. 8-7).

If fuel injection nozzles are not damaged, dirty, or out of adjustment, proceed to step 2.

Step 2. Check for damaged head gasket.

If head gasket is damaged, replace head gasket (para. 12-4).

If head gasket is not damaged, proceed to step 3.

Step 3. Check valves, guides, and springs for damage and wear.

If valves, guides, or springs are damaged or worn, replace as required (para. 12-4).

If valves, guides, and springs are not damaged or worn, check for worn cylinder walls or piston rings.

Table 4-2. Troubleshooting-Continued

MALFUNCTION	TEST OR INSPECTION	CORRECTIVE ACTION
9. Engine Oil Consumption Excessive.	Step 1. Check for worn or damaged valves, guides, stem and seals,	If valves, guides, stems, or seals are damaged or worn, replace as required (para. 12-4).
		If valves, guides, stems, or seals are not damaged, proceed to step 2.
	Step 2. Check for sticking oil pump pressure relief valve.	If valve is sticking, clean or replace valve (para. 10-4 ).
		If valve is not sticking, proceed to step 3.
	Step 3. Check for worn or broken piston rings.	If piston rings are broken or worn, replace rings (para. 12-10).
		If piston rings are not broken or worn, proceed to step 4.
	Step 4. Check for leaking oil seals.	If oil seals are leaking, replace seals (para. 12-10).
		If seals are not leaking check for and unclog oil return passages.
10. Low Engine Oil Pressure.	Step 1. Check for sticking oil pump pressure valve,	If oil pump pressure valve is sticking, clean or replace as required (para. 10-4).
		If valve is not sticking, proceed to step 2.
	Step 2. Check for damaged oil pump.	If oil pump is damaged, repair or replace as needed (para. 10-4).
		If oil pump is not damaged, proceed to step 3.

Table 4-2. Troubleshooting-Continued

**MALFUNCTION**

**TEST OR INSPECTION**

**CORRECTIVE ACTION**

---

Step 3. Check main bearings for wear.

If main bearings are worn, replace bearings (para. 12-10).

If main bearings are not worn, check camshaft bearings for wear.

**BRAKES**

1. Brakes Fail.

Step 1. Check all airlines and connections for leaks.

If leaks are detected, repair or replace airlines or fittings.

If no leaks are detected, proceed to step 2.

Step 2. Check for defective brake chamber.

If brake chamber is defective, replace brake chamber (para. 19-10).

If brake chamber is not defective, proceed to step 3.

Step 3. Check for defective relay valve.

If relay valve is defective, replace relay valve (para. 19-7).

If relay valve is not defective, proceed to step 4.

Step 4. Check for defective brake shoes, or grease or oil on brake shoes.

Replace defective/oily brake shoes (para. 19-12).

If brake shoes are not defective or oily, check air lines for leaks and repair as needed.

2. Brakes Noisy.

Check for out of round brake drums.

If brake drum is out of round, turn or replace brake drum (para. 19-12).

If brake drum is not out of round, replace brake shoes.

Table 4-2. Troubleshooting-Continued

**MALFUNCTION****TEST OR INSPECTION****CORRECTIVE ACTION**

## 3. Brakes Grab.

Step 1. Check for brakes out of adjustment.

If brakes are out of adjustment, adjust brakes (para. 19-6).

If brakes are not out of adjustment, proceed to step 2.

Step 2. Check for defective relay valve.

If relay valve is defective, replace valve (para. 19-7).

If relay valve is not defective, replace brake shoes.

**WHEELS**

## 1. Wheel Hub Throws Grease.

Step 1. Check for improper wheel bearing lubricant.

If wheel bearing needs lubricating, lubricate (19-5).

If wheel bearing does not need lubricating, proceed to step 2.

Step 2. Check for loose or cracked hub cap.

If hub cap is loose, tighten the hub cap (para. 19-5).

If hub cap is cracked, replace the hub cap (para. 19-5).

If hub cap is not loose nor cracked, proceed to step 3.

Step 3. Check for cracked hub.

If hub is cracked, replace hub (para. 19-5).

If hub is not cracked, proceed to step 4.

Step 4. Check for worn or damaged grease seals.

If seals are worn or damaged, replace the seals (para. 19-5).

If the seals are not worn or damaged, proceed to step 5.

Step 5. Check for defective hub gasket.

Replace hub gasket if required (para. 19-5).

Table 4-2. Troubleshooting-Continued

**MALFUNCTION**

**TEST OR INSPECTION**

**CORRECTIVE ACTION**

2. Wheel Bearings Overheat.

Check bearings for proper lubrication.

If bearings are not lubricated, lubricate bearings (para. 19-5).

If bearings are lubricated, check and adjust wheel bearings (para. 19-5).

3. Wheels Wobble.

Step 1. Check for loose wheel on hub.

If wheel is loose, tighten wheel nuts (para. 19-4).

If wheel is not loose, proceed to step 2.

Step 2. Check for damaged or bent wheel.

If wheel is damaged or bent, replace wheel (para. 19-4).

If wheel is not damaged or bent, proceed to step 3.

step 3. Check for wheel bearing out of adjustment or defective.

Replace defective wheel bearing or adjust wheel bearing (para. 19-5).

VAN BODY

1. Shop Set Body Is Low On One Side.

Inspect for damaged spring U-bolt or broken spring.

Replace broken or damaged parts (para. 19-14).

2. Side Doors Do Not Operate Properly.

Step 1. Inspect for a broken door hinge.

Replace broken door hinge (para. 15-1).

Step 2. Remove and disassemble lifting cylinder.

Replace damaged parts (para. 17-4).

Step 3. Remove and disassemble the side lifting hydraulic pump.

Replace damaged parts (para. 17-3).

Table 4-2. Troubleshooting-Continued

**MALFUNCTION****TEST OR INSPECTION****CORRECTIVE ACTION**

## DYNAMOTOR-WELDER

1. Dynamotor-Welder Noisy.
 

Remove and disassemble the welder. Inspect for damaged bearings.

Replace damaged bearings (para. 13-9).
2. Dynamotor-Welder Does Not Develop Welding Current.
 

Step 1. Check the brush tension, and for burned or worn brushes.

Adjust brush spring tension or replace brushes (para. 13-4).

Step 2. Remove and disassemble the welder and inspect for the interpole coils, compound coils, field coils, commutator, DC resistance element, and the armature.

Remove and correct as necessary. Clean commutator. Adjust exciter brush tension or replace brushes (paras. 13-1 through 13-10).
3. Dynamotor-Welder Does Not Furnish Alternating Current.
 

Remove and disassemble welder to inspect the rotating coils for excitation voltage, damaged field, and/or defective stator coils.

Repair, replace, or adjust brush tension as necessary (paras. 13-1 through 13-10).
4. Dynamotor-Welder Will Not Function As A Motor (External Power).
 

Remove and disassemble welder to inspect the stator coils, armature, and main contactor switch.

Repair or replace as necessary (paras. 13-1 through 13-10).
5. Dynamotor-Welder Exciter Does Not Furnish Excitation Voltage Or Voltage Is Below Required Level.
 

Step 1. Inspect for burned and badly worn brushes.

Adjust brush spring tension or replace brushes (para. 13-4).

Step 2. Remove and disassemble welder to check for dirty commutator and defective field coils and armature.

Table 4-2. Troubleshooting-Continued

**MALFUNCTION**

**TEST OR INSPECTION**

**CORRECTIVE ACTION**

6. Abnormal Fluctuations of Dynamotor-Welder Output Current.

Step 1. Check for dirty rheostat contact.

Clean contact.

Step 2. Disassemble welder to check brush tension.

Adjust brush tension or replace brushes (para. 13-4).

**AIR COMPRESSOR**

1. Compressor Pumping Oil.

Step 1. Check cylinders or piston for wear, scratches, or scoring.

Replace defective cylinder or piston (para. 14-11).

Step 2. Check for piston rings broken or not seated in.

Replace piston rings (para. 14-11).

2. Knocks or Rattles.

Step 1. Check for carbon on top of piston.

Clean as necessary (para. 14-11).

Step 2. Check for loose, broken, or carbonized air finger valves.

Replace defective finger valves (para. 14-11).

Step 3. Check for worn or scored connecting rod, piston pin, or crank pin bushings.

Replace defective parts (para. 14-11).

3. Air Delivery Dropping.

Step 1. Check for leaking, broken, carbonized, or loose finger valves.

Tighten or clean leaking or carbonized valves (para. 14-11). Replace defective valves (para. 14-11).

Step 2. Check for scratched, worn or scored cylinders or pistons.

Replace damaged piston rings (para. 14-11).



Table 4-2. Troubleshooting-Continued

**MALFUNCTION****TEST OR INSPECTION****CORRECTIVE ACTION**

- 
4. Motor Overload Relay Trips.
- Step 1. Check line voltage.
- Tighten loose connections. Replace defective fuses (para. 18-3).
- Step 2. Check for leaking, broken, or carbonized valves, or restricted air passages.
- Remove restrictions from air passages (para. 14-11).
5. Excessive Starting or Stopping.
- Step 1. Check the receiver check valve for defects.
- Remove any dirt, dust, or blockage from seat. Replace defective check valve (para. 14-6).
- Step 2. Check pressure switch for wear.
- Replace defective pressure switch (para. 14-4).
6. Compressor Running Hot.
- Step 1. Check for blockage of air to fanwheel.
- Remove any restriction to flow of air.
- Step 2. Check for defective check valve in receiver.
- Clean or replace check valve as necessary.
- Step 3. Check for leaking, broken, carbonized, or loose valves.
- Clean or replace valves as necessary (para. 14-11).
7. Compressor Running Slow.
- Check for low line voltage or a defective starter heater.
- Tighten loose connections. Replace a defective motor starter or heater (para. 14-8).

---

## Section VII. GENERAL MAINTENANCE

### 4-17. GENERAL.

- a. This section includes brief descriptions for repairs which are allocated to direct support and general support maintenance which would otherwise be repeated several times throughout the chapters.
- b. Before removal or disassembly of a component, inspect the overall condition and note all symptoms of faulty operation. This helps determine causes of failure of faulty operation, and facilitates repair.
- c. Provide a clean place to work, facilities for cleaning the engine, compressor, welder, and shop body parts and overhaul stand.
- d. Standard engine overhaul shop tools and resurfacing equipment are necessary. These tools save time and insure good workmanship.
- e. Engine components and parts are overhauled in one of the following systems: Lubrication System, Cooling System, Fuel System, Air Supply, Exhaust Systems, Electrical System, and Engine. Components and parts will be removed as necessary. Note any precautions and special procedures.
- f. Check all wiring for cracks and frayed places. Pay particular attention to places where wires pass through holes in the frame or over sharp metal edges.
- g. Solder all terminal connections to insure good electrical contact.
- h. Test electrical leads for continuity. Disconnect each end of the wire from the components. to which it is connected.

---

## Section VIII. RADIO INTERFERENCE SUPPRESSION

### 4-18. GENERAL METHODS USED TO ATTAIN PROPER SUPPRESSION.

Essentially, suppression is attained by providing a low resistance path to ground for the stray currents. The methods used include shielding the ignition and high-frequency wires, grounding the frame with bonding straps, and using capacitors and resistors.

### 4-19. INTERFERENCE SUPPRESSION COMPONENTS.

- a. Primary Suppression Components. The primary suppression components are those whose primary function is to suppress radio interference. These components are described and located in figure 4-12.
- b. Secondary Suppression Components. These components have radio interference suppression functions which are incidental or secondary to their primary function.

- 4-20. REPLACEMENT OF SUPPRESSION COMPONENTS.** Refer to figure 4-12 and replace the radio interference suppression components.
- 4-21. TESTING OF SUPPRESSION COMPONENTS.** Test the capacitors for leaks and shorts on a capacitor tester; replace defective capacitors. If test equipment is not available, and interference is indicated, isolate the cause of interference by the trial and error method of replacing each capacitor in turn until the cause of the interference is located and eliminated.

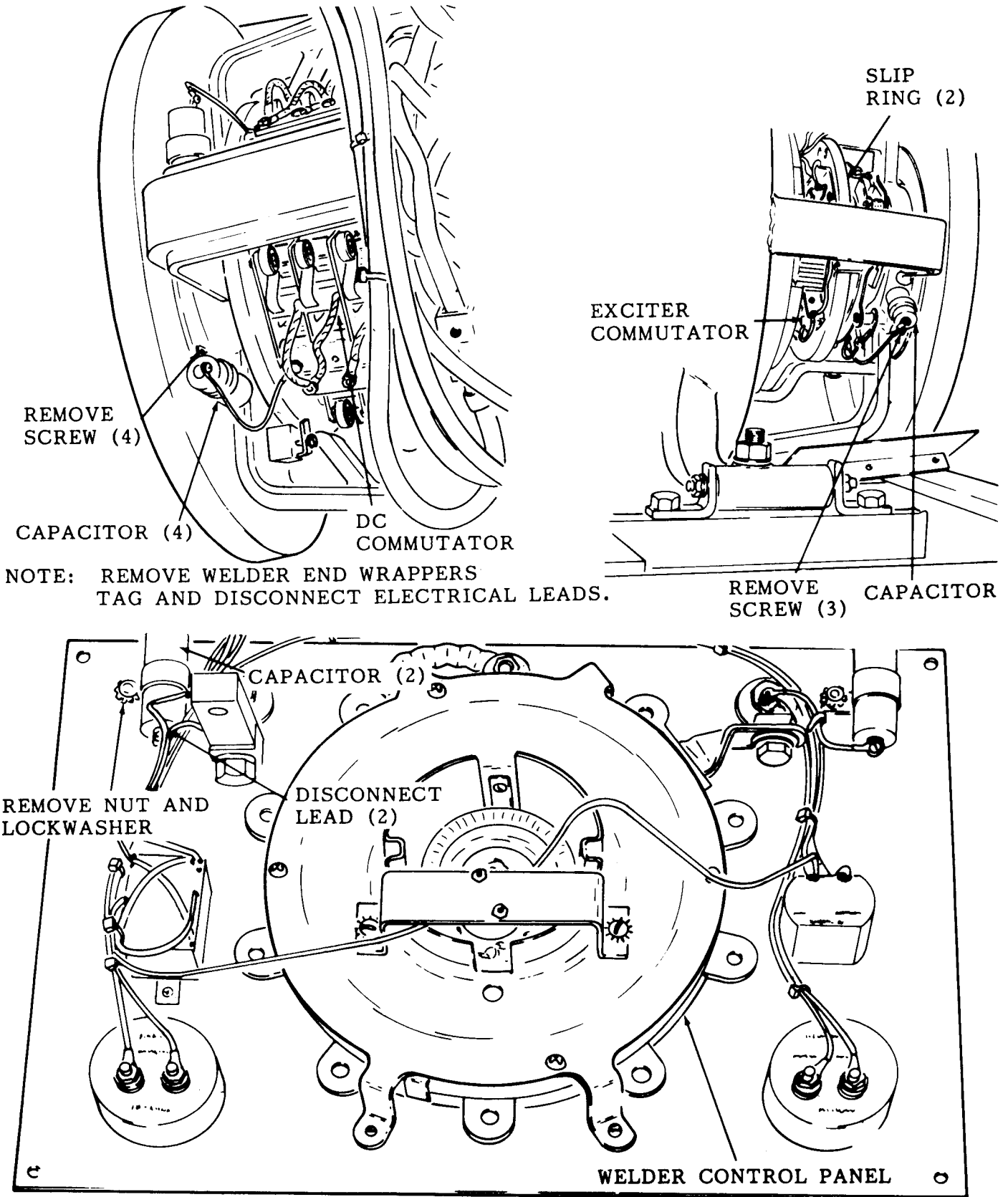
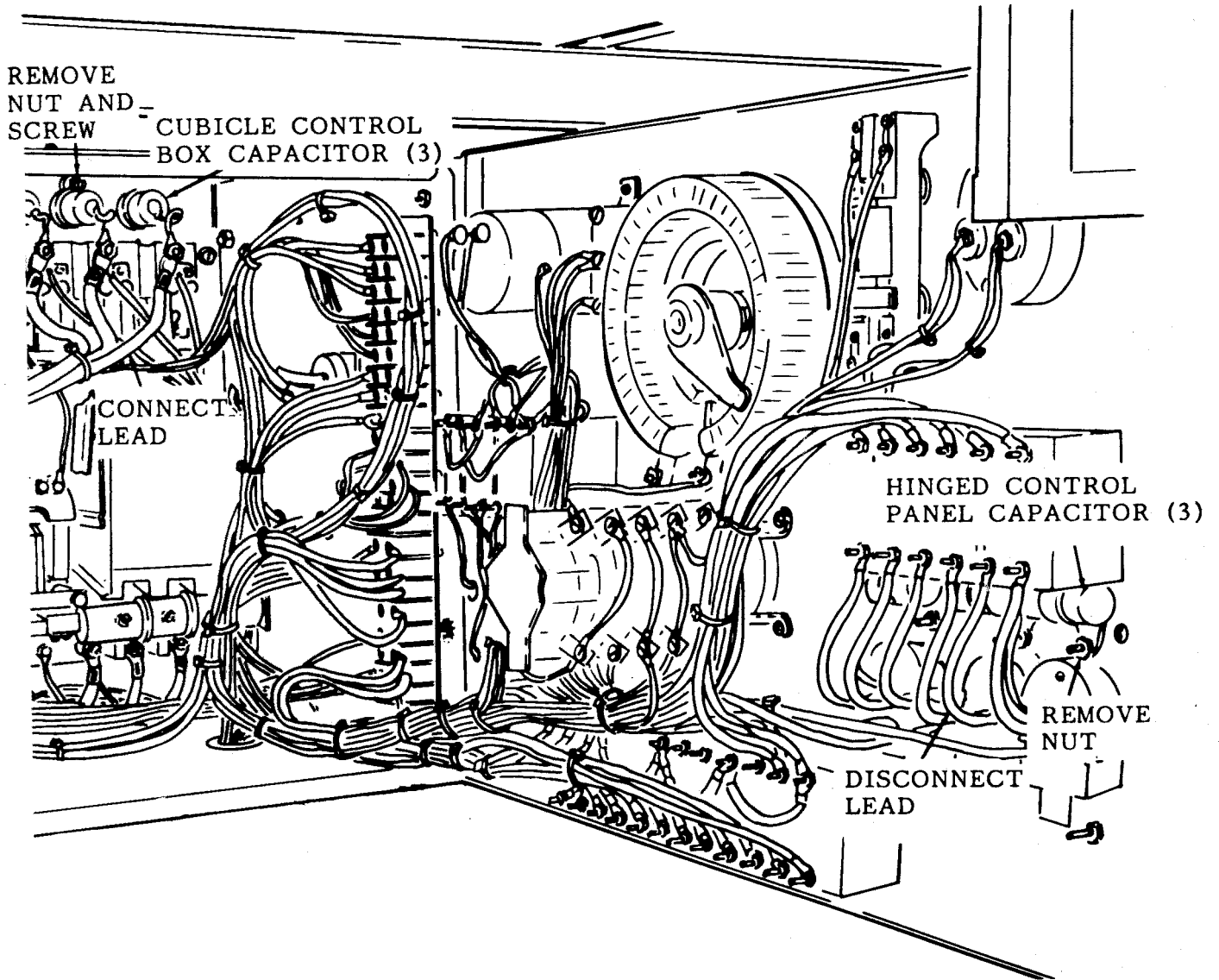


Figure 4-12. Interference Suppression Components, Removal and Installation (Sheet 1 of 2).



D. CUBICLE CAPACITORS AND HINGED CONTROL PANEL CAPACITORS.

Figure 4-12. Interference Suppression Components, Removal and Installation (Sheet 2 of 2).



## CHAPTER 5

REMOVAL AND INSTALLATION OF MAJOR COMPONENTS

---

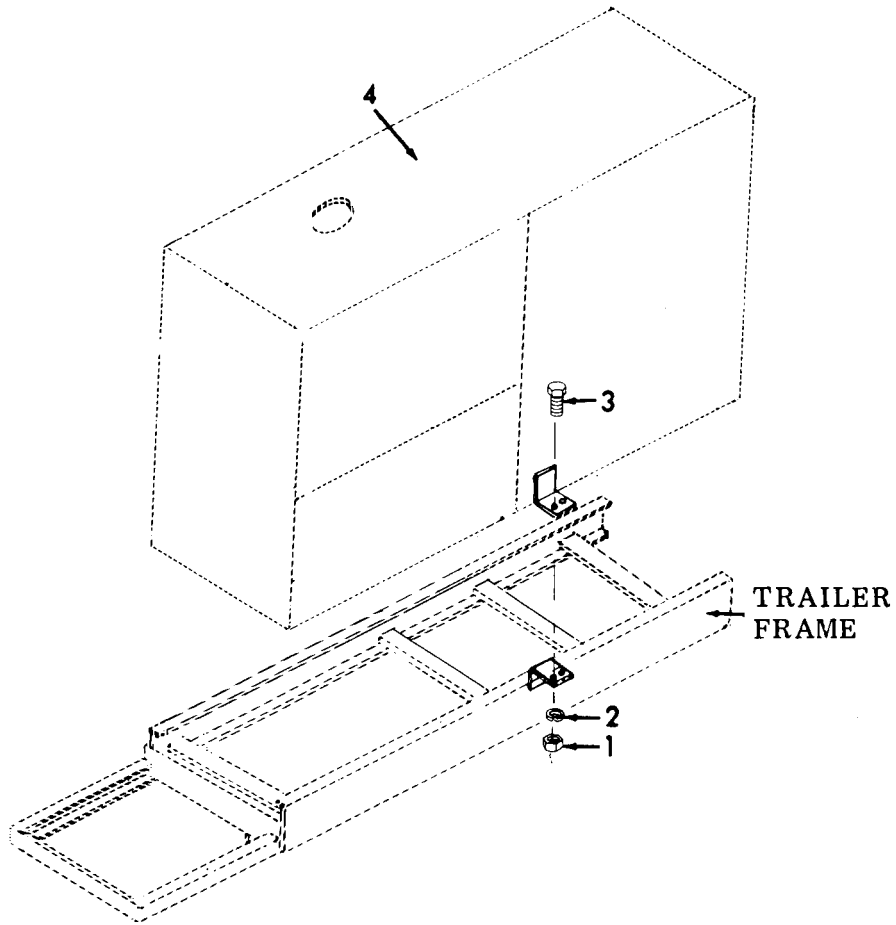
## 5-1. ENGINE ENCLOSURE.

a. Removal.

- (1) Remove the ladder from its stowed position on the right side of the engine enclosure.
- (2) Disconnect the shutter control cable from the shutter assembly and remove the four clamps securing the cable to the enclosure.
- (3) Remove the muffler.
- (4) Drain and remove the fuel tank assembly(para 8-2).
- (5) Disconnect the front clearance lights at the trailer wiring harness.
- (6) Refer to figure 5-1 and remove the four nuts (1), four washers (2), and four screw (3) that secure the engine housing to the trailer frame.
- (7) Attach a suitable lifting device to the engine housing (4).
- (8) Move the engine housing (4) forward until the housing (4) is free to move upward.
- (9) Lift away the engine housing (4).

b. Installation (Refer to figure 5-1).

- (1) Use a suitable lifting device and lower the engine housing (4) into position.
- (2) Secure the engine housing (4) to the trailer frame with four screws (3), four washers (2), and four nuts (1).
- (3) Connect the front clearance lights to the trailer wiring harness.
- (4) Install the fuel tank assembly (para 8-2).
- (5) Install the muffler.
- (6) Install the ladder to its stowage position on the right side of the engine enclosure.
- (7) Connect the shutter control cable to the shutter assembly and secure the cable to the enclosure.



LEGEND FOR FIGURE 5-1:

ITEM	NSN	PIN	FSCM	QTY
1. Nut	5310-00-732-0558	MS51967-8	96906	4
2. Washer	5310-00-637-9541	MS35338-46	96906	4
3. Screw, Cap	5305-00-269-3211	MS90-725-60	96906	4
4. Engine Housing Assy.		13217E0481-1	98255	1

Figure 5-1. Engine Enclosure, Removal and Installation.



**5-2. ENGINE.**a. Removal.

- (1) Remove the engine enclosure.
- (2) Remove the battery box.
- (3) Disconnect the sending units.
- (4) Disconnect all cables and lines.
- (5) Remove the screws (fig. 5-2) that secure the engine.
- (6) Use a suitable lifting device and move the engine forward to clear the clutch housing.
- (7) Lift away the engine.

b. Installation.

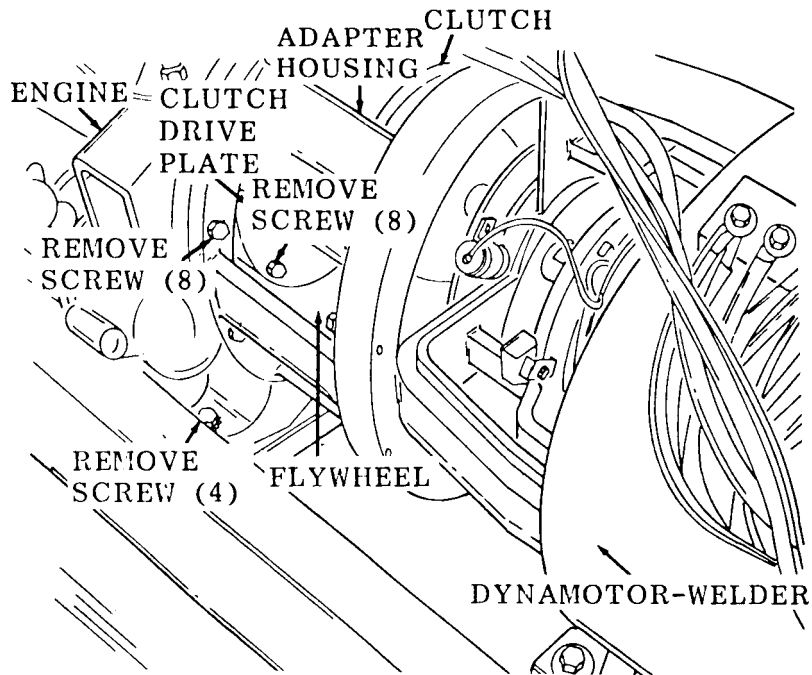
- (1) Use a suitable lifting device and lift the engine into position.
- (2) Refer to figure 5-2 and install the screws that secure the engine.
- (3) Connect all cables and lines.
- (4) Connect the sending units.
- (5) Install the battery box and engine enclosure.

**5-3. DYNAMOTOR-WELDER.**a. Removal.

- (1) Remove the engine enclosure.
- (2) Remove the engine.
- (3) Tag and disconnect all electrical wiring.
- (4) Refer to figure 5-2 and remove the four screws.
- (5) Use a suitable lifting device and remove the dynamotor-welder.

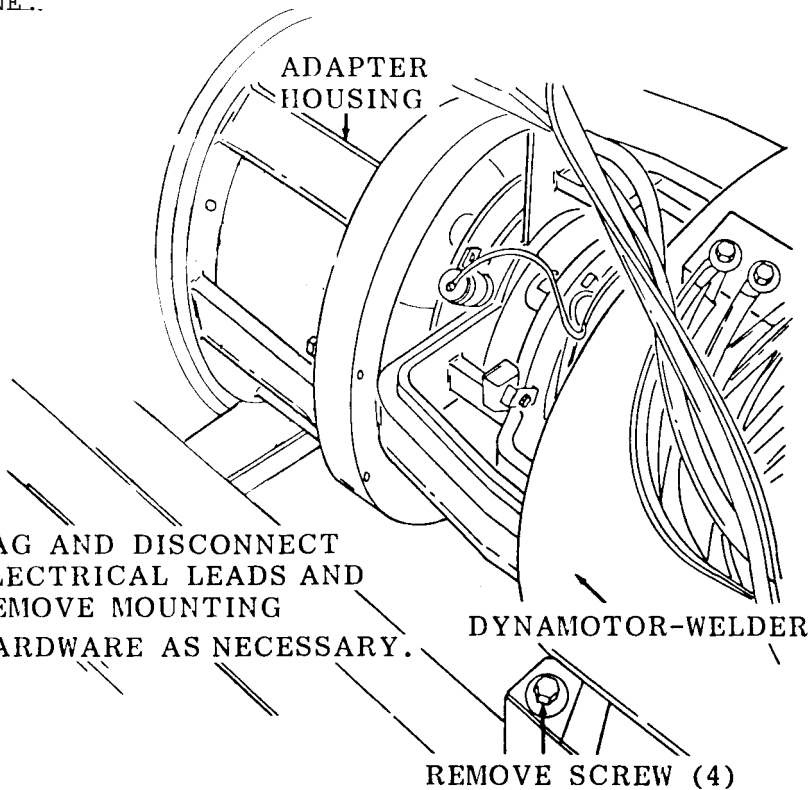
b. Installation.

- (1) Use a suitable lifting device and place the dynamotor-welder into position.
- (2) Refer to figure 5-2 and install four screws.
- (3) Connect the electrical leads per tagged identification.



NOTE TAG AND DISCONNECT ELECTRICAL LEADS AND REMOVE MOUNTING HARDWARE AS NECESSARY.

A. ENGINE..



NOTE: TAG AND DISCONNECT ELECTRICAL LEADS AND REMOVE MOUNTING HARDWARE AS NECESSARY.

B. DYNAMOTOR-WELDER.

Figure 5-2. Engine and Dynamotor-Welder, Removal and Installation.

- (4) Install the engine.
- (5) Install the engine enclosure.

**5-4. CONTROL CUBICLE.**

a. Removal.

- (1) Be sure that all electrical power has been removed.
- (2) Tag and disconnect electrical leads as required.
- (3) Refer to figure 5-3 and remove the control cubicle.

b. Installation.

- (1) Refer to figure 5-3 and install the control cubicle.
- (2) Connect all electrical leads per tagged identification.

**5-5. SHOP BODY.**

a. Removal.

- (1) Disconnect the 24-volt wiring harness running inside the left frame member, beneath the front end and rear of the shop body.
- (2) Disconnect the personnel heater.
- (3) Refer to figure 5-4 and remove the attaching hardware.
- (4) Attach a suitable lifting device and remove the shop body.

b. Installation.

- (1) Attach a suitable lifting device and place the shop body into position.
- (2) Refer to figure 5-4 and install the attaching hardware.
- (3) Connect the personnel heater.
- (4) Connect the 24-volt wiring harness beneath the front end and rear of the shop body.

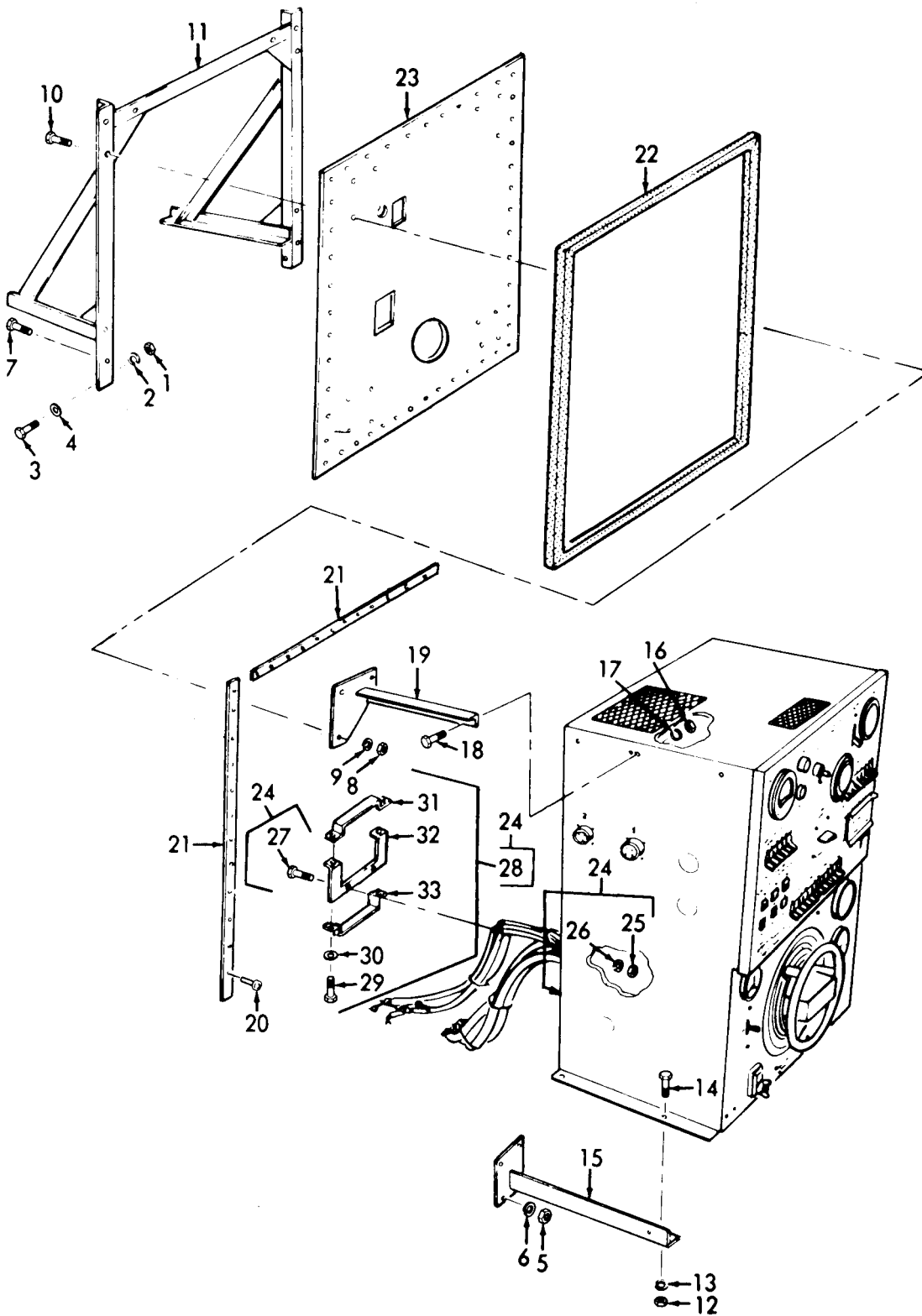


Figure 5-3. Control Cubicle, Removal and Installation.

## LEGEND FOR FIGURE 5-3:

ITEM	NSN	P/N	FSCM	QTY
1. Nut, Plain	5310-00-768-0318	MS51967-14	96906	2
2. Washer, Lock	5310-00-584-5272	MS35338-48	96906	6
3. Screw, Cap	5305-00-071-1764	MS90725-104	96906	6
4. Washer, Flat	5310-00-809-5998	MS27183-18	96906	2
5. Nut, Plain	5310-00-891-1754	MS35691-18	96906	8
6. Washer, Lock	5310-00-637-9541	MS35338-46	96906	8
7. Screw, Cap	5305-00-269-3213	MS90725-62	96906	8
8. Nut, Plain	5310-00-891-1754	MS35681-18	96906	6
9. Washer, Lock	5310-00-637-9541	MS35338-46	96906	6
10. Screw, Cap	5310-00-959-7072	MS90725-262	96906	6
11. Bracket, Box		353492	28835	1
12. Nut, Plain	5310-00-891-1754	MS35691-18	96906	4
13. Washer, Lock	5310-00-637-9541	MS35338-46	96906	4
14. Screw, Cap	5305-00-942-2196	MS90725-60	96906	4
15. Support, LH		353487	28835	1
15. Support, RH		353488	28835	1
16. Nut, Plain	5310-00-891-1754	MS35691-18	96906	4
17. Washer, Lock	5310-00-637-9541	MS35338-46	96906	4
18. Screw, Cap	5305-00-942-2196	MS90725-60	96906	4
19. Support, LH		353490	28835	1
19. Support, RH		353491	28835	1
20. Screw, Tapping	5305-00-855-0964	MS24629-48	96906	50
21. Retainer		11G8245	98255	4
22. Seal		11H8497	98255	1
23. Panel		353798	28835	1
24. Box Assy		358947	28835	1
25. Nut, Plain	5310-00-931-3175	MS35691-10	96906	2
26. Washer, Lock	5310-00-407-9566	MS35338-45	96906	2
27. Screw, Machine	5305-00-958-5251	MS35190-303	96906	2
28. Clamp Assy.		354009	28835	1
29. Screw, Cap	5305-00-225-9081	MS90725-36	96906	2
30. Washer, Lock	5310-00-407-9566	MS35338-45	96906	2
31. Clamp		354003	28835	1
32. Clamp		354001	28835	1
33. Bracket		354002	28835	1

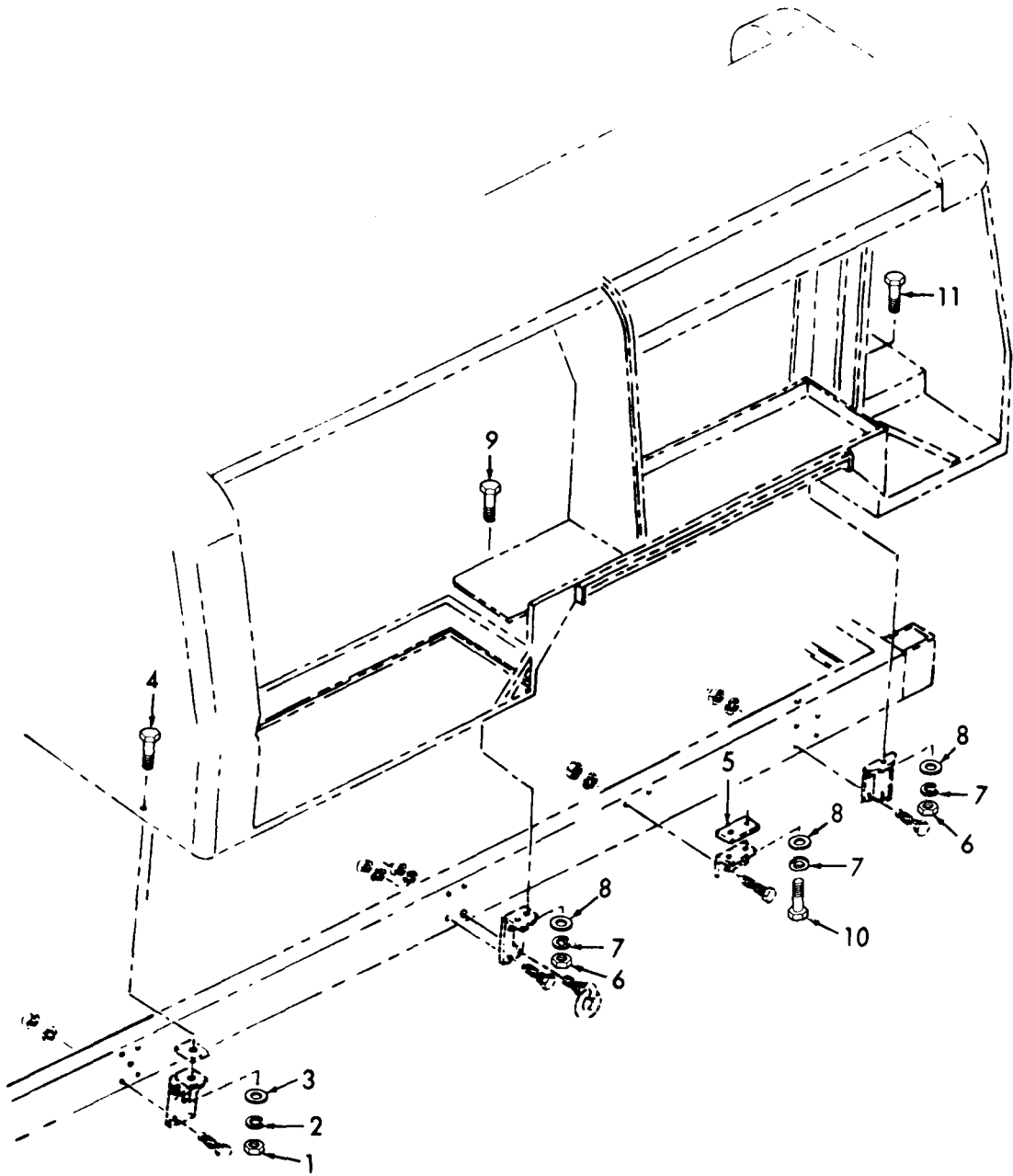


Figure 5-4. Shop Body, Removal and Installation.

## LEGEND FOR FIGURE 5-4:

ITEM	NSN	P/N	FSCM	QTY
1. Nut, Plain	5310-00-762-6239	MS51968-29	96906	2
2. Washer, Lock	5310-00-584-7889	MS35338-53	96906	2
3. Washer, Flat	5310-00-809-8541	MS27183-27	96906	2
4. Screw, Cap	5305-00-958-8479	MS90726-236	96906	2
5. Spacer		13217E1115	97403	2
6. Nut, Plain	5310-00-763-8921	MS51967-23	96906	6
7. Washer, Lock	5310-00-584-7888	MS35338-51	96906	10
8. Washer, Flat	5310-00-809-8533	MS27183-23	96906	10
9. Screw, Cap	5305-00-939-9204	MS90725-187	96906	4
10. Screw, Cap	5305-00-948-0748	MS90726-183	96906	4
11. Bolt, Machine		FF-G-575	81348	2
12. Van Assy.		13217E0550	97403	1





## CHAPTER 6

MAINTENANCE OF ELECTRICAL SYSTEM

---

**6-1. WIRING.**

- a. General. Check insulation for cracks and frayed places. Pay particular attention to places where wires pass through holes in the frame or over sharp metal edges. If any wire is found to be defective, replace it following its respective wiring diagram. Solder all terminal connections to insure good electrical contact. If the defective wire is part of a rubber, molded wiring harness, and cannot be replaced without disassembly, replace the harness.
- b. Testing 110-volt Wiring. Remove all power. Test the electrical leads for continuity. Disconnect each end of the wire from the components to which it is connected (refer to wiring diagram). Check for continuity and replace any defective wire with the same size wire as removed. Reinstall the circuit tag number.
- c. Testing 24-Volt Wiring Harness. Refer to the appropriate wiring diagram and test the harness for continuity in the same manner as described in b above.
- d. Replacement {Refer to figures 6-1, 6-2, and FO-1 thru FO-4}.
  - (1) Tag and disconnect all electrical leads as necessary.
  - (2) To replace a wire that is not part of a wiring harness, disconnect it at each end and install a new wire of the same wire size as the one removed.
  - (3) If a defective wire is part of a wiring harness or cable assembly that cannot be reassembled, replace the entire harness or cable assembly.
  - (4) Connect lead as tagged in (1) above. Reinstall the circuit tag number.

**6-2. SERVICE AND BLACKOUT CLEARANCE LIGHTS.**

- a. Removal. Remove the service and blackout clearance lights as illustrated in figure 6-3.
- b. Cleaning and Inspection.
  - (1) Clean all parts with approved cleaning solvent and dry thoroughly.
  - (2) Inspect all parts for damaged threads, bends, cracks, breaks and other damage. Inspect for a defective lamp and any corrosion. Replace any defective parts.
- c. Installation. Install the service and blackout clearance lights as illustrated in figure 6-3.

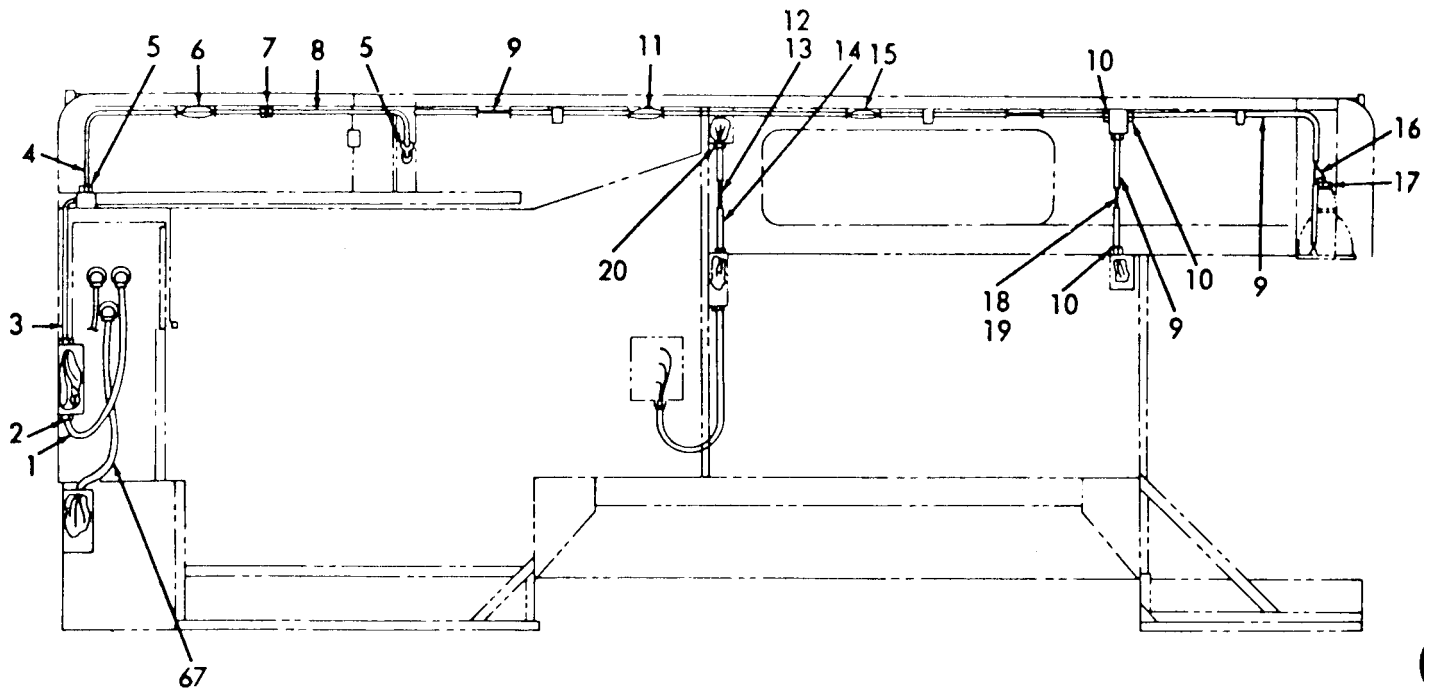


Figure 6-1. 110 Volt Electrical Installation (Sheet 1 of 6).

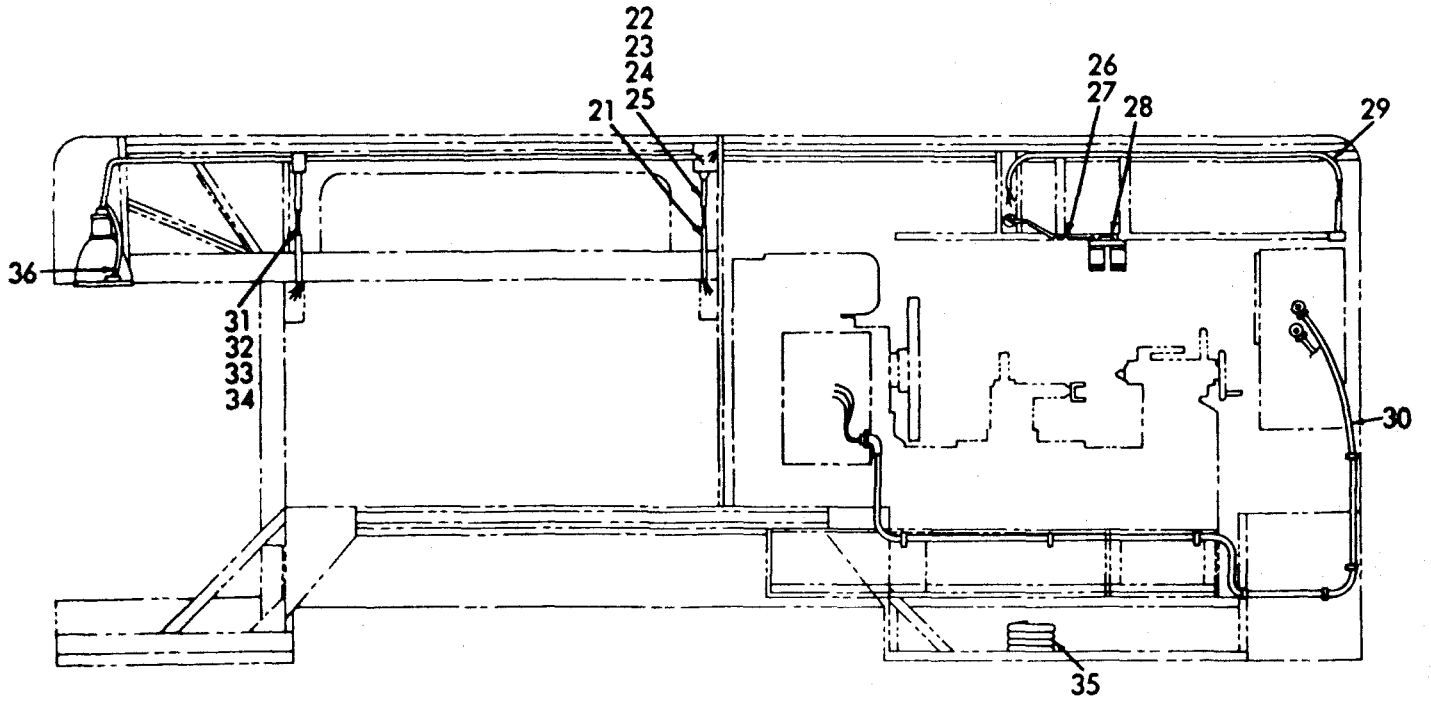


Figure 6-1. 110 Volt Electrical Installation (Sheet 2 of 6).

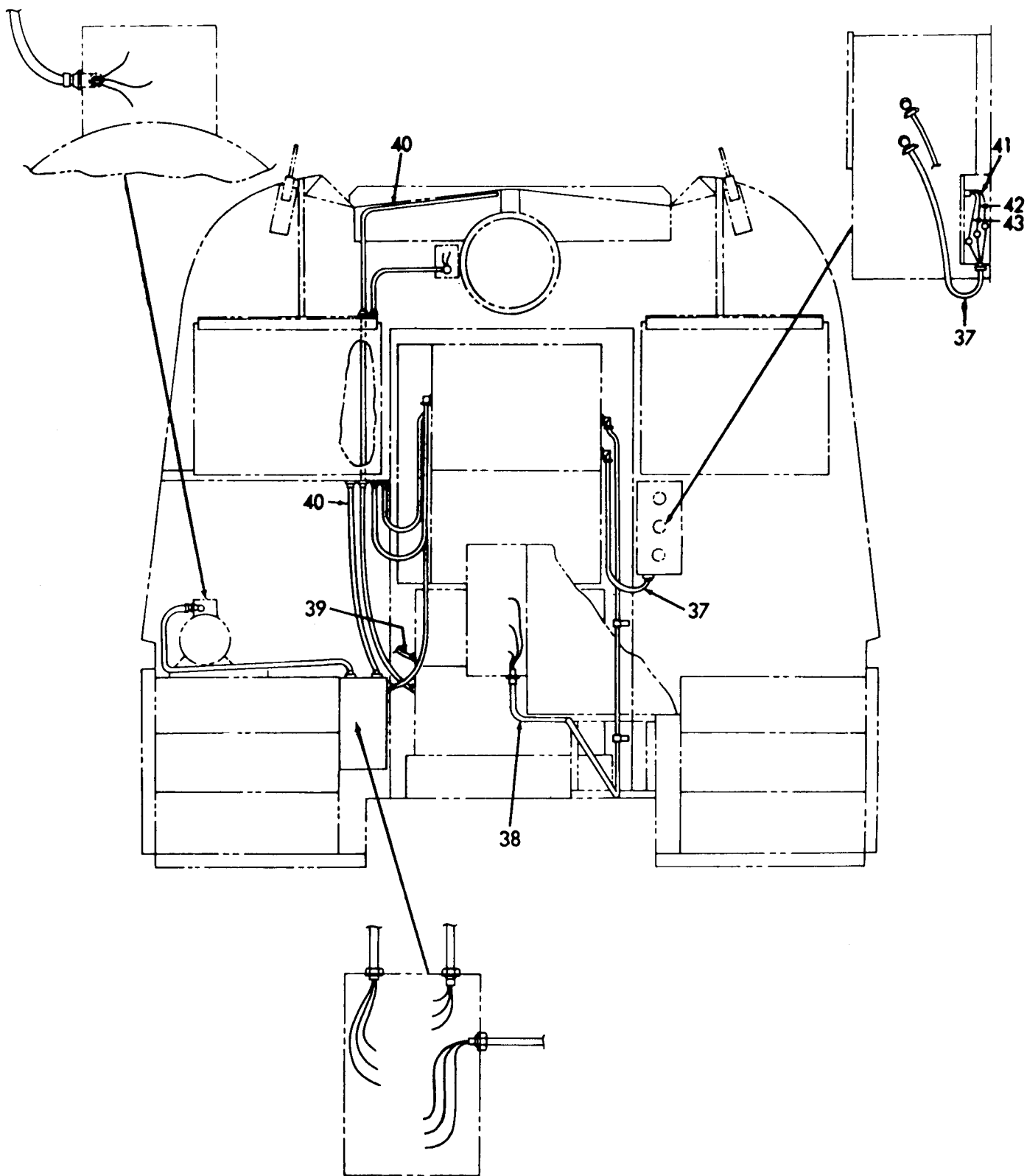


Figure 6-1. 110 Volt Electrical Installation (Sheet 3 of 6).

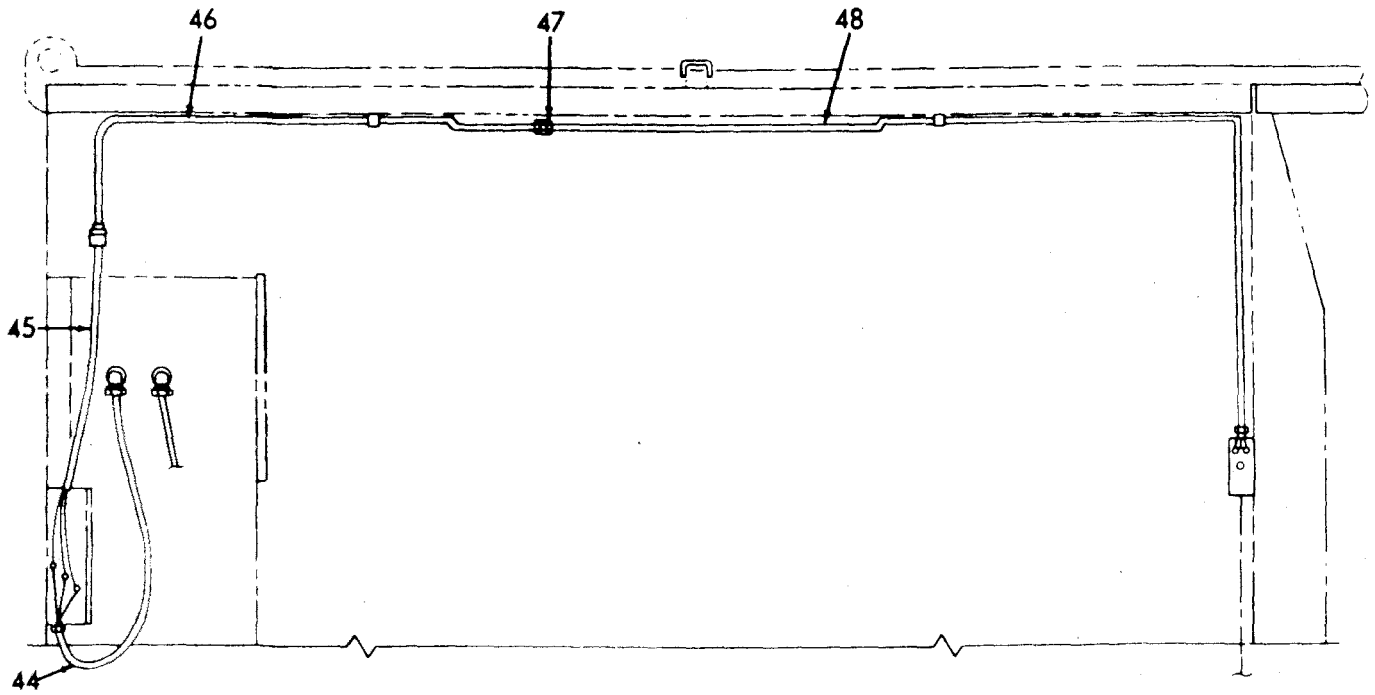


Figure 6-1. 110 Volt Electrical Installation (Sheet 4 of 6).

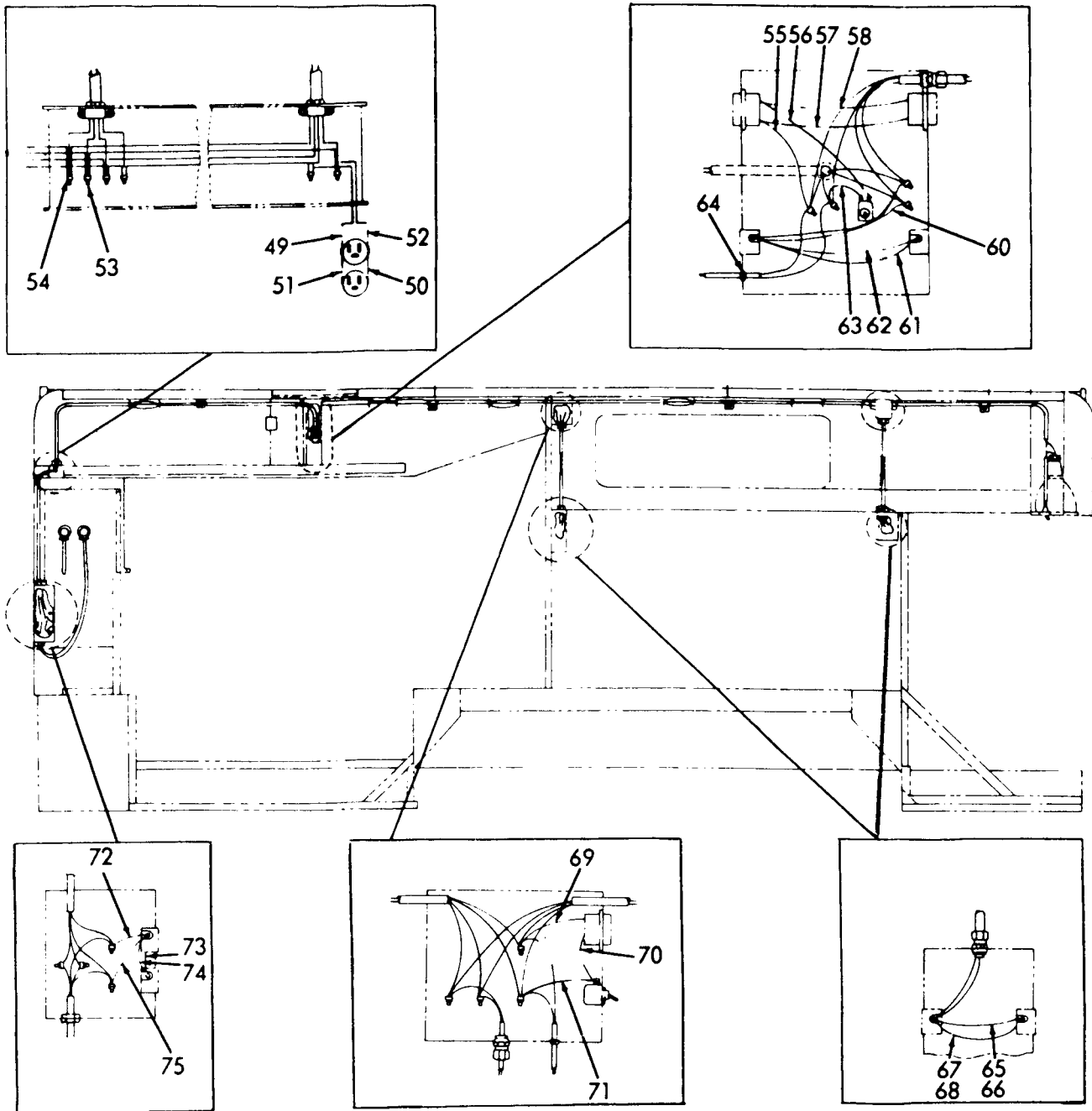


Figure 6-1. 110 Volt Electrical Installation (Sheet 5 of 6).

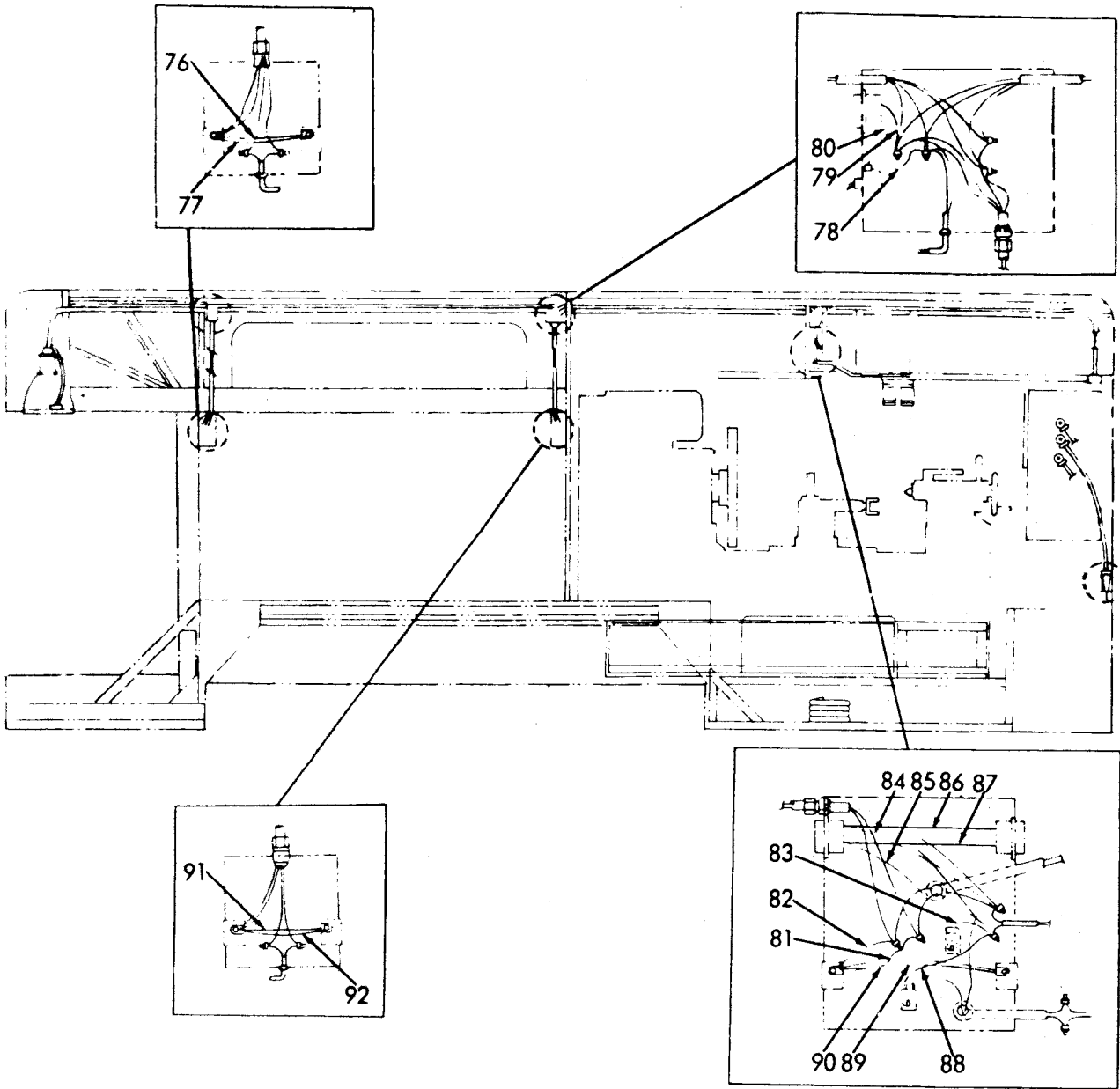


Figure 6-1. 110 Volt Electrical Installation (Sheet 6 of 6).

## LEGEND FOR FIGURE 6-1:

ITEM	NSN	P/N	FSCM	QTY
1. Assembly, Cable		13217E0916	97403	1
2. Fitting		13218E0003-80	97403	1
3. Harness, Wiring		13217E0917	97403	1
4. Conduit, Rigid		SW8756P2	98255	1
5. Fitting		SW1615P	98255	4
6. Harness, Wiring		13217E0919	97403	1
7. Fitting		SW7426P3	98255	2
8. Conduit, Rigid		SW8756P1	98255	1
9. Conduit, Rigid		SW1617P1	98255	1
10. Fitting		SW1616P	98255	16
11. Harness, Wiring		13217E092072	97403	1
12. Assembly, Lead		13217E0928-41	97403	1
13. Assembly, Lead		13217E0928-42	97403	1
14. Conduit		SW12175M	98255	1
15. Harness, Wiring		13217E0922-2	97403	1
16. Harness, Wiring		13217E0924-2	97403	1
17. Fitting		13218E0003-79	97403	8
18. Assembly, Lead		13217E0928-48	97403	1
19. Assembly, Lead		13217E0928-49	97403	1
20. Grommet, Rubber	5325-00-720-9054	MS35490-20	96906	2
21. Conduit, Rigid		SW8757P1	98255	1
22. Assembly, Lead		13217E0928-21	97403	1
23. Assembly, Lead		13217E0928-22	97403	1
24. Assembly, Lead		13217E0928-55	97403	1
25. Assembly, Lead		13217E0928-54	97403	1
26. Assembly, Lead		13217E0928-11	97403	1
27. Assembly, Lead		13217E0928-9	97403	1
28. Fitting		SW1619P	98255	2
29. Harness, Wiring		13217E0918	97403	1
30. Assembly, Cable		13217E0927	97403	1
31. Assembly, Lead		13217E0928-28	97403	1
32. Assembly, Lead		13217E0928-29	97403	1
33. Assembly, Lead		13217E0928-58	97403	1
34. Assembly, Lead		13217E0928-57	97403	1
35. Assembly, Cable		13217E0915	97403	1
36. Harness, Wiring		13217E0924-1	97403	1
37. Assembly, Cable		13217E0923	97403	1
38. Assembly, Cable		13217E0907	97403	1
39. Assembly, Cable		13217E0921-2	97403	1
40. Cable, Electrical		SW1652P	98255	1
41. Assembly, Lead		13217E0928-52	97403	1
42. Assembly, Lead		13217E0928-53	97403	1
43. Assembly, Lead		13217E0928-54	97403	1
44. Assembly, Cable		13217E0926	97403	1
45. Harness, Wiring		13217E0925	97403	1
46. Conduit, Rigid	5975-00-178-1216	WW-C-563	81348	1
47. Fitting		SW7426P1	98255	1



## LEGEND FOR FIGURE 6-1 -- Continued:

ITEM	NSN	P/N	FSCM	QTY
48. Conduit, Rigid		SW8757P2	98255	1
49. Assembly, Lead		13217E0928-5	97403	1
50. Assembly, Lead		13217E0928-7	97403	1
51. Assembly, Lead		13217E0928-8	97403	1
52. Assembly, Lead		13217E0928-6	97403	1
53. Splice		13217E0942-2	97403	2
54. Insulator		13217E0943-3	97403	2
64. Grommet, Rubber	5325-00-290-6163	MS35489-13	96906	4
65. Assembly, Lead		13217E0928-44	97403	1
66. Assembly, Lead		13217E0928-43	97403	1
67. Assembly, Lead		13217E0928-50	97403	1
68. Assembly, Lead		13217E0928-51	97403	1
69. Assembly, Lead		13217E0928-45	97403	1
70. Assembly, Lead		13217E0928-47	97403	1
71. Assembly, Lead		13217E0928-46	97403	1
72. Assembly, Lead		13217E0928-1	97403	1
73. Assembly, Lead		13217E0928-4	97403	1
74. Assembly, Lead		13217E0928-3	97403	1
75. Assembly, Lead		13217E0928-2	97403	1
76. Assembly, Lead		13217E0928-23	97403	1
77. Assembly, Lead		13217E0928-24	97403	1
78. Assembly, Lead		13217E0928-26	97403	1
79. Assembly, Lead		13217E0928-25	97403	1
80. Assembly, Lead		13217E0928-27	97403	1
81. Assembly, Lead		13217E0928-12	97403	1
82. Assembly, Lead		13217E0928-13	97403	1
83. Assembly, Lead		13217E0928-18	97403	1
84. Assembly, Lead		13217E0928-16	97403	1
85. Assembly, Lead		13217E0928-19	97403	1
86. Assembly, Lead		13217E0928-17	97403	1
87. Assembly, Lead		13217E0928-20	97403	1
88. Assembly, Lead		13217E0928-10	97403	1
89. Assembly, Lead		13217E0928-14	97403	1
90. Assembly, Lead		13217E0928-15	97403	1
91. Assembly, Lead		13217E0928-30	97403	1
92. Assembly, Lead		13217E0928-31	97403	1

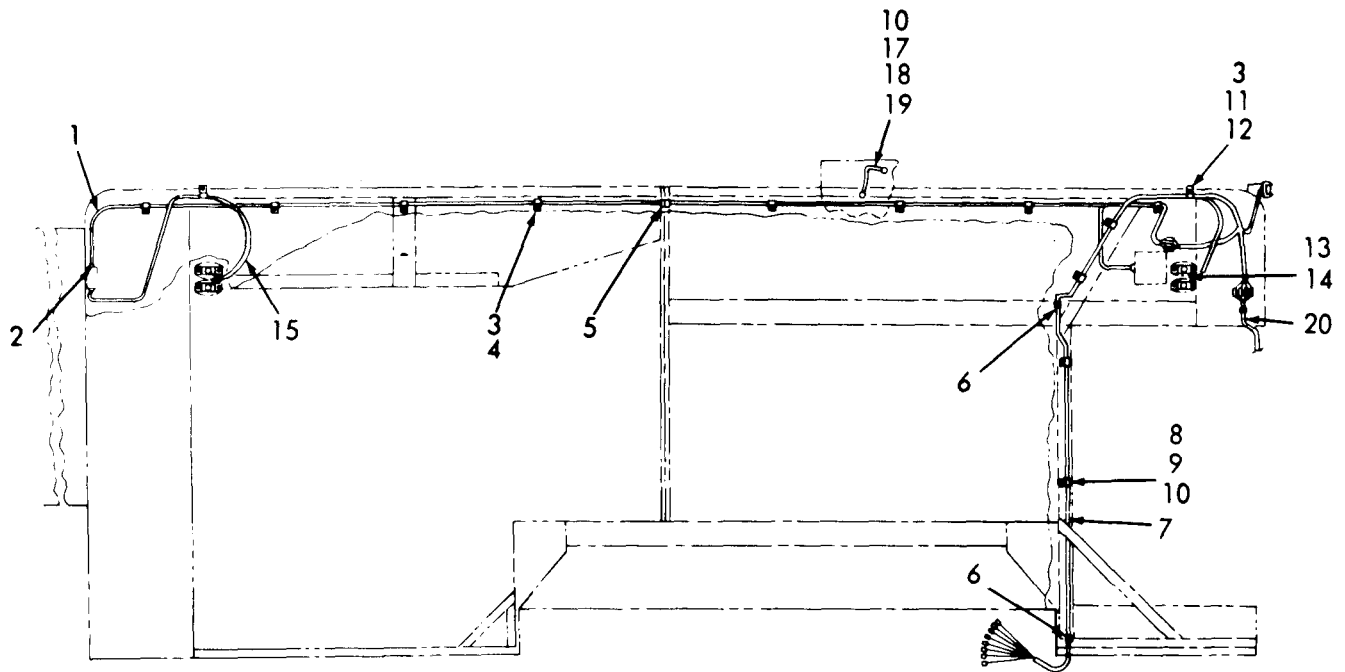


Figure 6-2. 24 Volt DC Electrical Installation (Sheet 1 of 2).

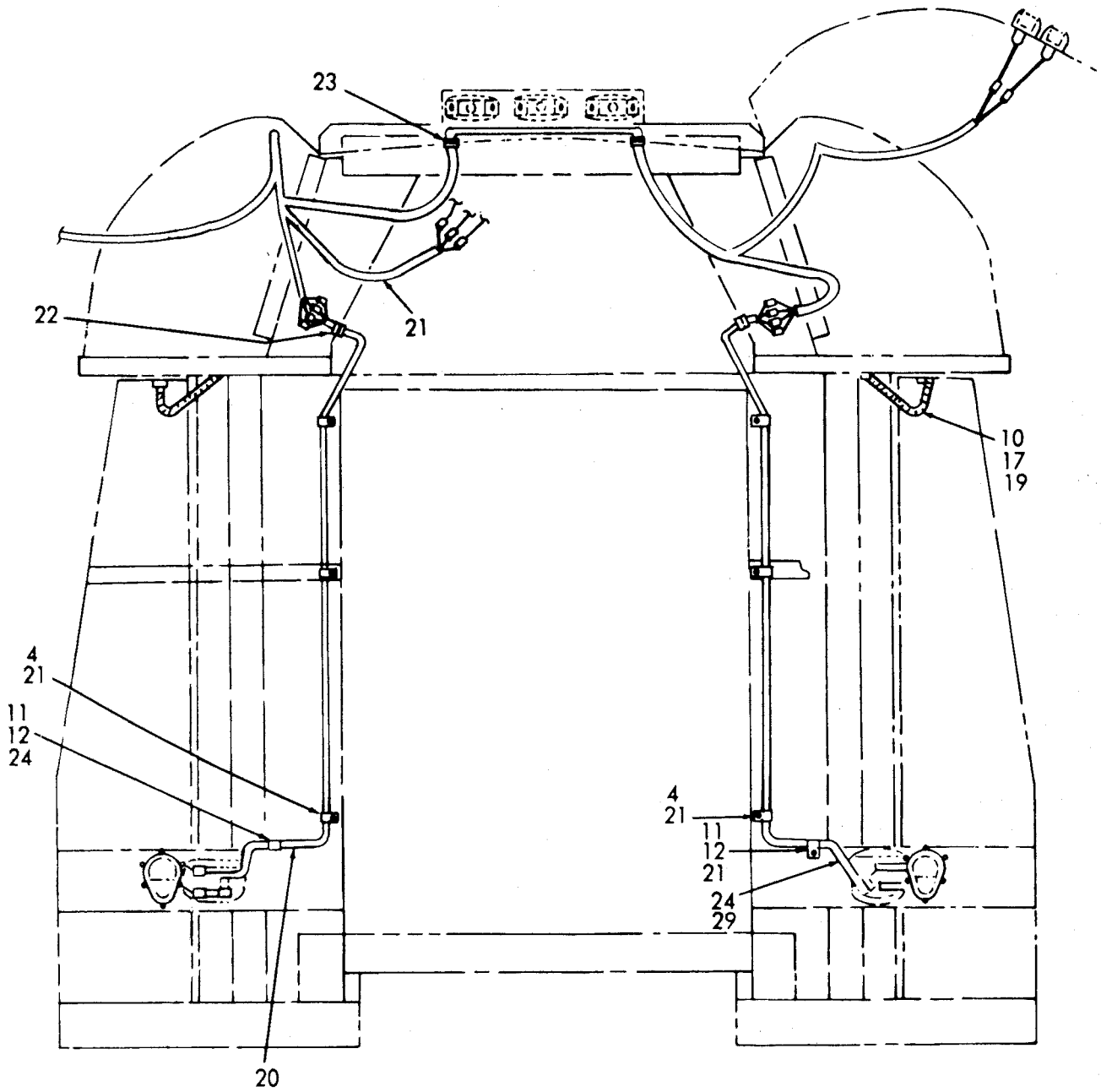
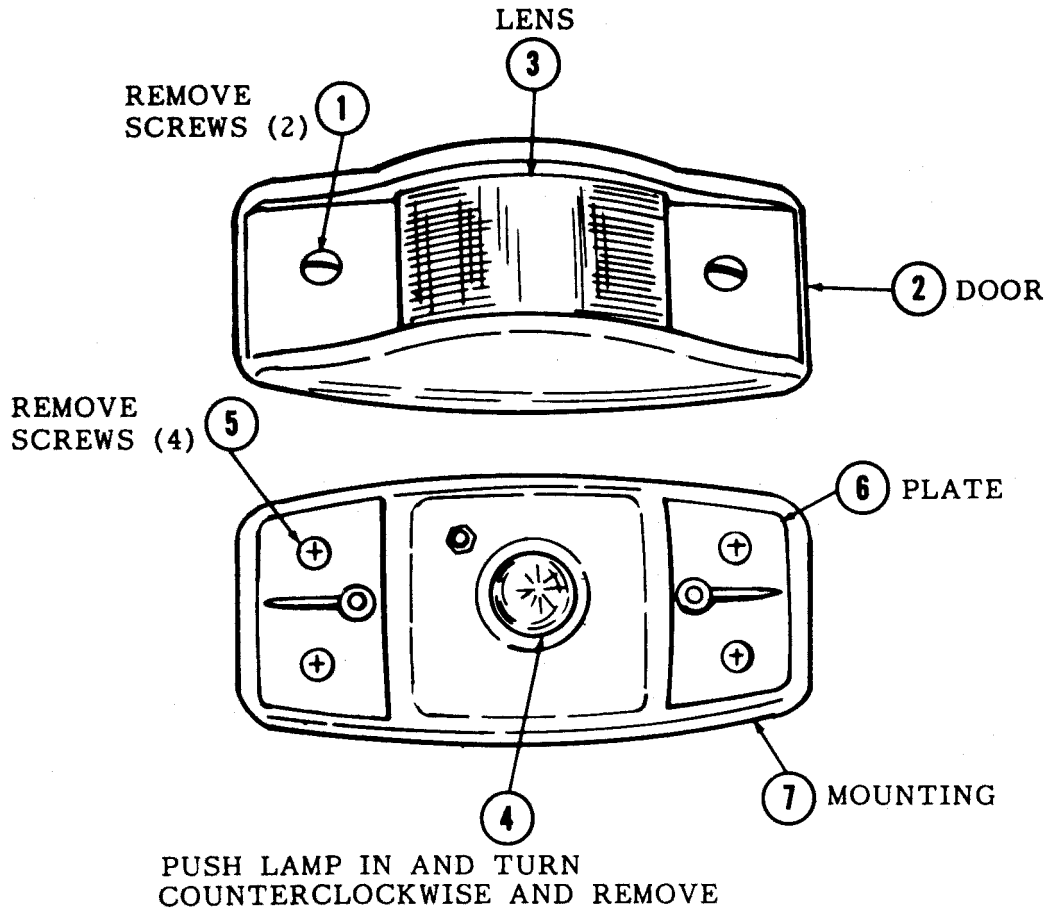


Figure 6-2. 24 Volt DC Electrical Installation (Sheet 2 of 2).

## LEGEND FOR FIGURE 6-2:

I	NSN	P/N	FSCM	QTY
1. Assembly, Cable		13217E0906	59678	1
2. Fitting	5975-00-199-9563	13217E0003-1	97403	3
3. Clamp	5340-00-057-2904	MS21333-71	96906	12
4. Screw	5305-00-432-4201	MS51861-45	96906	14
5. Grommet, Rubber	5325-00-276-6098	MS51861-45	96906	1
6. Grommet, Rubber	5325-00-270-8890	MS35489-22	96906	1
7. Lead Electrical	6150-00-725-1185	MS25083-2CC12	96906	1
8. Assembly, Cable		13217E1402	59678	1
9. Clamp, Loop	5340-00-809-1494	MS21333-105	96906	4
10. Screw	5305-00-068-0501	MS90725-5	96906	4
11. Nut	5310-00-088-1251	MS51922-1	96906	12
12. Screw	5305-00-989-7435	MS35207-264	96906	6
13. Nut	5310-00-440-9912	MS51988-2	96906	6
14. Shell	5935-00-572-9180	13212E4472-1	59678	14
15. Washer	5310-00-833-8567	13212E4473	59678	14
16. Assembly, Cable		13217E1403-2	59678	1
17. Assembly, Cable		13217E1403-1	59678	1
18. Assembly, Lead	2590-01-056-3637	13217E0913	59678	4
19. crew	5305-00-068-0500	MS90725-3	96906	6
20. Screw	5305-00-225-3839	MS90725-8	96906	2
21. Harness, Wiring		13217E0938	59678	1
22. Assembly, Cable		13217E1405-2	59678	1
23. Clamp, Loop	5340-00-057-2904	MS21333-71	96906	6
24. Grommet, Rubber	5325-00-281-1557	MS35490-17	96906	2
25. Grommet	5325-00-763-2916	13217E0914	59678	2
26. Assembly, Cable		13217E1405-1	59678	1
27. Terminal Board	5940-00-891-7446	524	89020	2
28. Screw, Tapping	5305-00-432-4172	MS51861-37	96906	4
29. Band, Marker		M4346/4-1	81439	22

NOTE: TAG AND DISCONNECT ELECTRICAL LEADS.



NOTE: REMOVE REMAINING SERVICE AND BLACKOUT CLEARANCE LIGHTS IN A SIMILAR MANNER.

LEGEND FOR FIGURE 6-3:

ITEM	NSN	P/N	FSCM	QTY
1. Screw	5305-00-984-7361	MS35191-270	96906	2
2. Door, Light	6220-00-752-5992	7526516	19207	1
3. Lens -Amber	6220-00-752-5992	MS35420-1		
-Red	6220-00-752-5993	MS35420-2	96906	1
4. Lamp	6240-00-019-0877	MS15570-1251	96906	1
5. Screw	5305-00-883-0628	MS24617-21	96906	4
6. Plate, Mounting	6250-00-371-4018	7526515	19207	1
7. Felt, Mechanical	5330-00-353-0959	7526509	19207	1

Figure 6-3. Service and Blackout Clearance Lights, Removal and Installation.

### 6-3. CONVENIENCE RECEPTACLES, LAMP BASES, AND TOGGLE SWITCHES.

a. Removal.

- (1). Switch all circuit breakers on the control panel to OFF and disconnect electrical power source.
- (2). Remove convenience receptacles, lamp bases, and toggle switches, as illustrated in figure 6-4.

b. Cleaning and Inspection.

- (1). Clean all metal parts with cleaning solvent and dry thoroughly.
- (2). Inspect all parts for cracks , dents, or other damage. Replace defective parts.
- (3). Inspect for defective hardware and loose connections. Replace defective hardware and be sure all electrical connections are clean and secure.
- (4). Inspect the wiring for breaks or damaged insulation. Repair or replace damaged wiring.

c. Installation. Install the convenience receptacle, lamp bases, and toggle switches, as illustrated in figure 6-4.

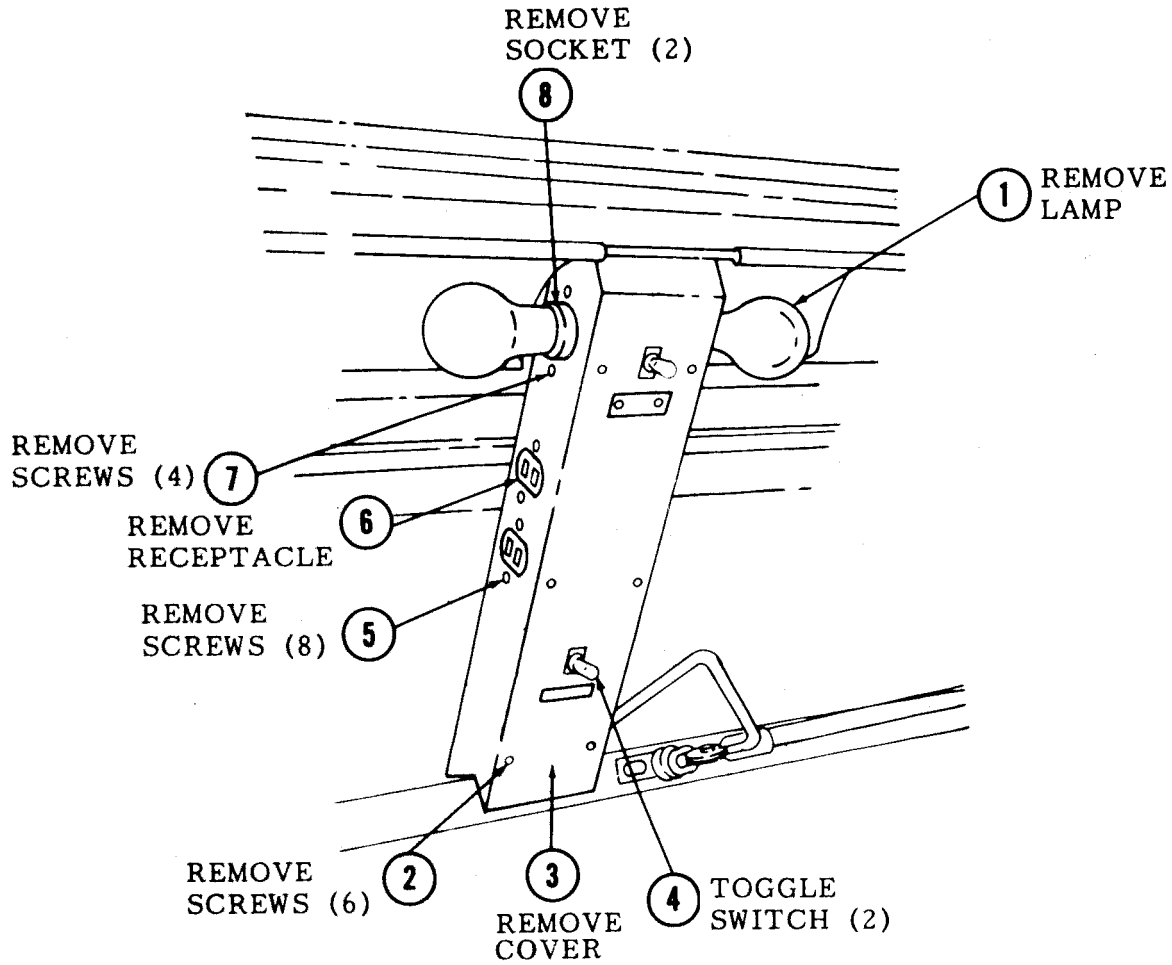
### 6-4. FLOODLIGHTS.

a. Removal. Remove the floodlight as illustrated in figure 6-5.

b. Cleaning and Inspection.

- (1) Clean all parts with a cloth dampened in cleaning solvent and dry thoroughly.
- (2) Inspect all parts for cracks, corrosion, and other defects. Replace a defective floodlight.

c. Installation. Install the floodlights as illustrated in figure 6-5.

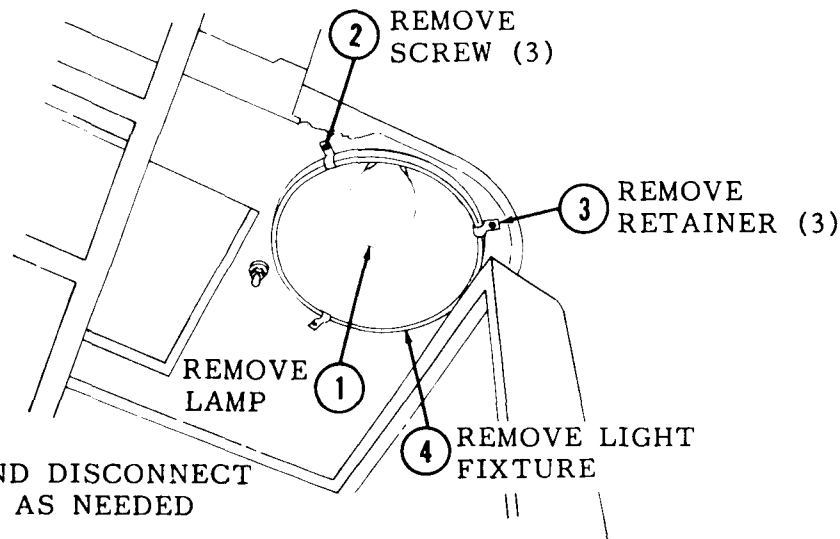


NOTE: TAG AND DISCONNECT ELECTRICAL LEADS AND REMOVE MOUNTING HARDWARE AS NECESSARY.

LEGEND FOR FIGURE 6-4:

ITEM	NSN	P/N	FSCM	QTY
1. Lamp, Incandescent, 50W.	6240-00-155-8634	MS15586-1	96906	2
2. Screw	5305-00-984-6210	MS35206-263	96906	6
3. Cover -Right	5975-00-482-4024	13217E1218	59678	1
-Left		13217E1219	59678	1
4. Switch, Toggle	5930-00-198-3938	13217E1013	59678	2
5. Screw	5305-00-984-6191	MS35206-243	96906	8
6. Receptacle, Wiring		13217E1216	59678	4
7. Screw	5305-00-889-3000	MS35206-230	96906	4
8. Socket, Light	6250-00-478-9061	13217E1224	59678	2

Figure 6-4. Convenience Receptacles, Lamp Bases, and Toggle Switches.



NOTE: TAG AND DISCONNECT WIRING AS NEEDED

LEGEND FOR FIGURE 6-5:

I	NSN	P/N	FSCM	QTY
1. Lamp Incandescent	6240-00-143-7493	W-L-101/84	81349	1
2. Screw	5305-00-432-4170	MS51861-35	96906	3
3. Retainer		13217E1154	59678	3
4. Fixture, Light		13217E1074	59678	1

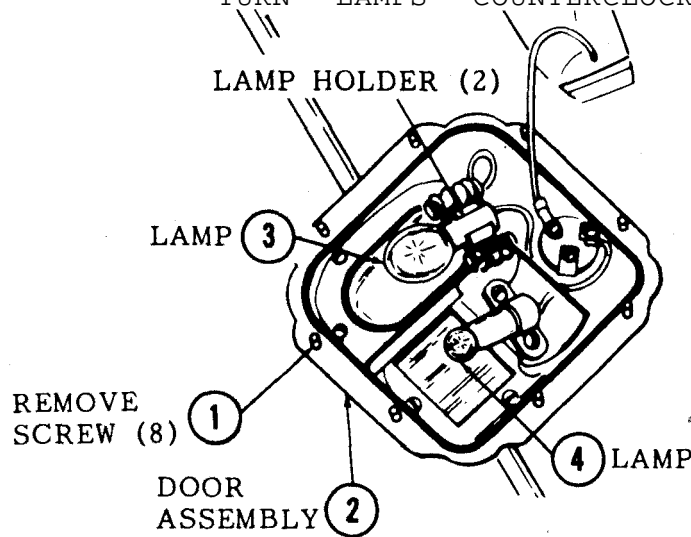
Figure 6-5. Floodlights, Removal and Installation.

**6-5. CEILING AND BLACKOUT LIGHT.**

- a. Incandescent Lamp Replacement (Refer to figure 6-6).
  - (1) Remove the eight screws (1) and separate the assembled door (2) from the body.
  - (2) Remove the lamp from the lampholder by pressing in and rotating one-quarter turn.
  - (3) Install new lamp, position assembled door on the body and secure with the eight screws.
- b. Removal (Refer to figure 6-7).
  - (1) Disconnect electrical lead.
  - (2) Remove four screws and remove the light assembly.
- c. Installation (Refer to figure 6-7).
  - (1) Position the light assembly against the panel and secure with four screws.
  - (2) Connect electrical lead.



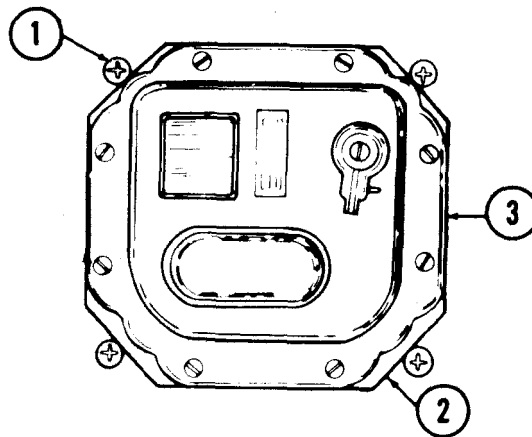
NOTE: TO REMOVE LAMPS, PRESS IN AND TURN LAMPS COUNTERCLOCKWISE.



LEGEND FOR FIGURE 6-6:

I		NSN	P/N	FSCM	QTY
1.	Screw	5305-00-737-5694	7320641	19207	8
2.	Door	6220-00-796-2241	7962241	19207	1
3.	Lamp	6240-00-295-2668	MS35478-1691	96906	1
4.	Lamp	6240-00-019-3093	MS15570-623	96906	1

Figure 6-6. Lamp Replacement.



LEGEND FOR FIGURE 6-7.

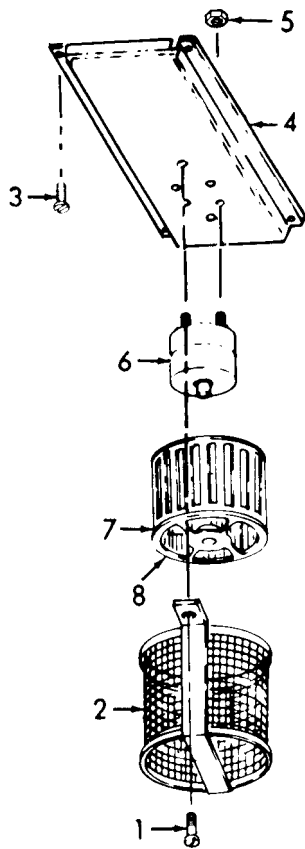
ITEM		NSN	P/N	FSCM	QTY
1.	Screw	5305-00-988-1725	MS35206-281	96906	4
2.	Assembly, Light	6220-00-337-7463	MS51073-1	96906	1
3.	Electrical Lead	6150-00-055-1751	7064899	19207	1

Figure 6-7. Light Assembly, Removal and Installation.

6-6. FRONT VENTILATOR FAN ASSEMBLY.

a. Removal.

- (1) Refer to figure 6-8, and remove the two screws (1) that secure the guard (2). Remove the guard (2).
- (2) Remove the four screws (3) that secure the bracket and remove the bracket (4).
- (3) Tag and disconnect the electrical leads; remove the two nuts (5) that secure the front ventilator fan assembly, and remove front ventilator fan assembly.



LEGEND FOR FIGURE 6-8:

ITEM	NSN	P/N	FSCM	QTY
1. Screw	5305-00-432-4170	MS51861-35	96906	2
2. Guard		13217	59678	1
3. Screw	5305-00-855-0960	MS24629-36	96906	4
4. Bracket		13217	59678	1
5. Nut	5310-00-934-9757	MS35649-282	96906	2
6. Motor	6105-00-437-5939	13217E1203	59678	1
7. Setscrew	5305-00-719-5338	MS51963-23	96906	1
8. Impeller		13217E1204	59678	1

Figure 6-8. Front Ventilator, Removal and Installation.

b. Cleaning and Inspection.

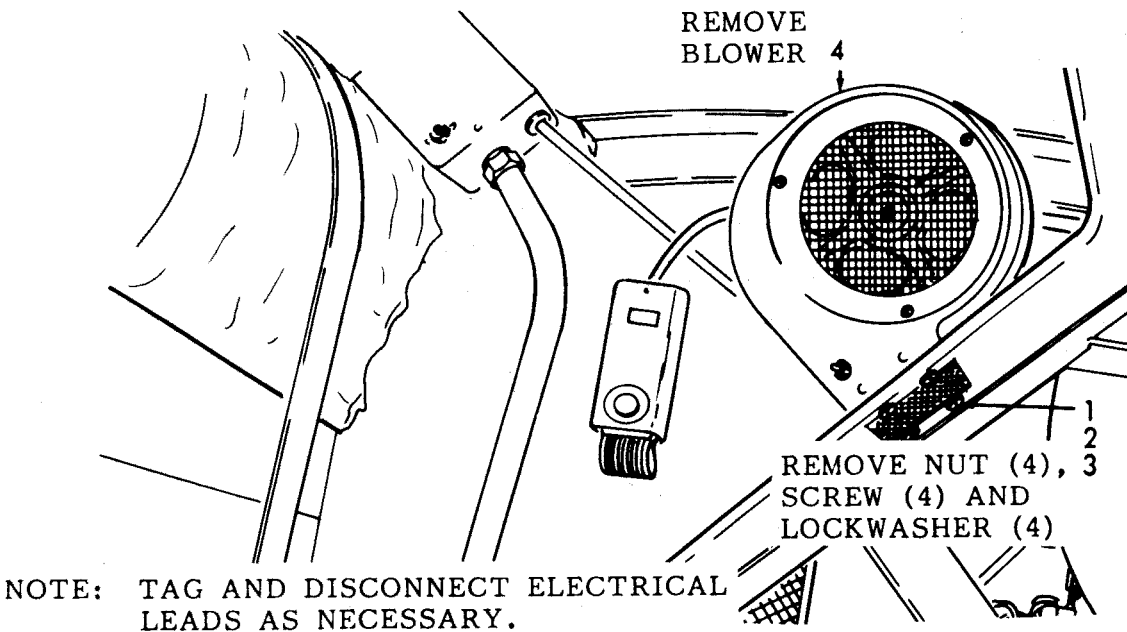
- (1) Clean parts with cleaning solvent and dry thoroughly. Do not submerge motor in solvent.
- (2) Inspect for defective bracket, guard, fan, and for defective or missing hardware. Replace as necessary.

c. Installation.

- (1) Refer to figure 6-8 and install the front ventilator fan (6 and 8) and secure with two nuts (5). Connect electrical leads.
- (2) Install the bracket (4) and secure with four screws (3).
- (3) Install the guard (2) and secure with two screws (1).

**6-7. REAR VENTILATOR FAN ASSEMBLY.**

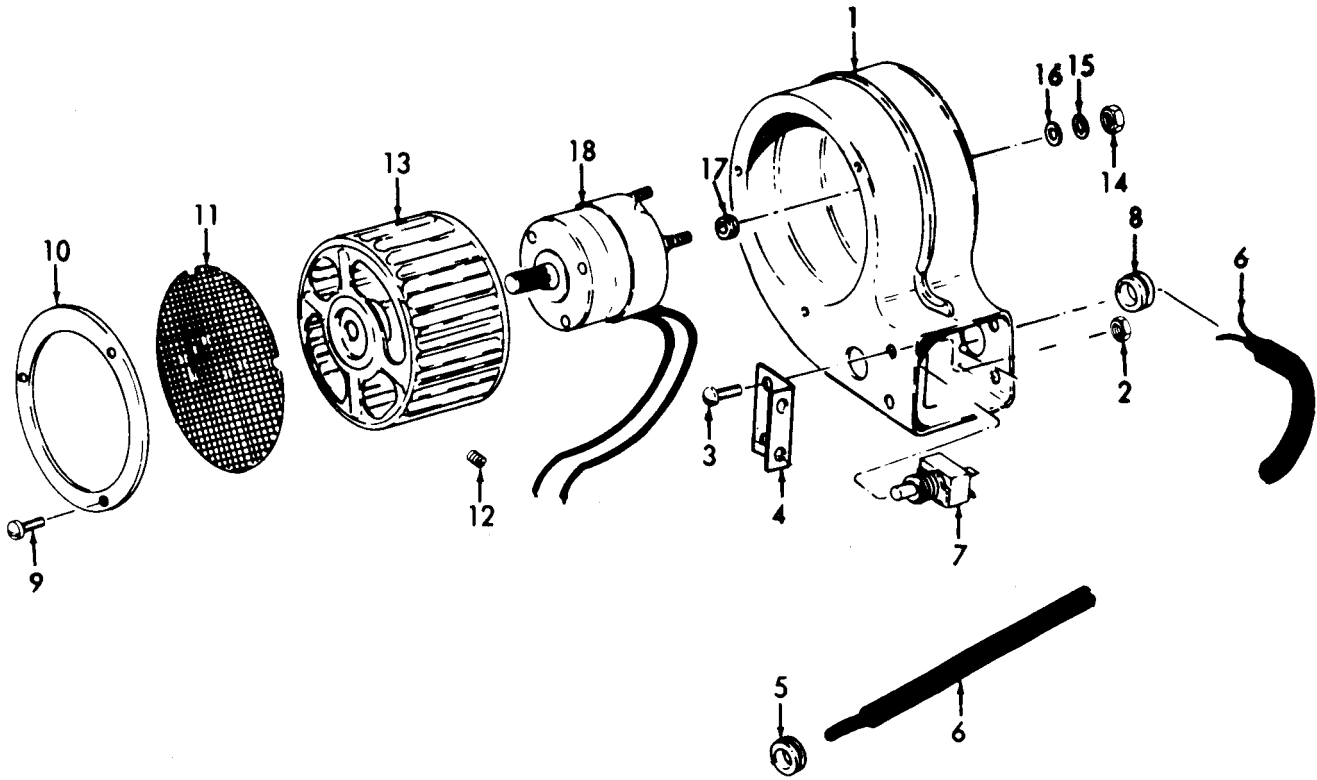
- a. Removal. Remove the rear ventilator fan assembly as illustrated in figure 6-9.
- b. Disassembly. Refer to figure 6-10 and disassemble the rear ventilator.



LEGEND FOR FIGURE 6-9:

ITEM	NSN	P/N	FSCM	QTY
1. Nut	5310-00-934-9758	MS35649-202	96906	4
2. Screw	5305-00-984-6210	MS35206-263	96906	4
3. Washer, Lock	5310-00-596-7691	MS35335-32	96906	4
4. Blower		13217	59678	1

Figure 6-9. Rear Ventilator Fan Assembly, Removal and Installation.



LEGEND FOR FIGURE 6-10:

ITEM	NSN	P/N	FSCM	QTY
1. Housing		0912-0269	16327	1
2. Nut	5310-00-934-9758	MS35649-202	96906	4
3. Screw	5305-00-984-6210	MS35206-263	96906	4
4. Angle		13217E1182	59678	2
5. Grommet	5325-00-543-3865	MS35490-37	96906	1
6. Harness		13217E1418	59678	1
7. Switch	5930-00-198-3938	13217E1013	59678	1
8. Grommet	5325-00-543-3865	MS35490-37	96906	1
9. Screw		0910-0027	16327	3
10. Ring		0910-0015	16327	1
11. Screen		13217E1185	59678	1
12. Setscrew	5305-00-724-6799	MS51964-51	96906	1
13. Impeller		0910-0023	16327	1
14. Nut		0001-0039	16327	1
15. Washer		0001-0046	16327	1
16. Washer		1126-0008	16327	1
17. Grommet		0911-0006	16327	1
18. Motor assembly		7300-6310	16327	1

Figure 6-10. Rear Ventilators, Disassembly and Removal.

c. Cleaning and Inspection.

(1) Clean with cleaning solvent and dry thoroughly. (Do not submerge motor in solvent

(2) Inspect for defective and missing parts or hardware. Replace as necessary.

d. Reassembly. Refer to figure 6-10 and reassemble the rear ventilator.

e. Installation. Install the rear ventilator fan assembly as illustrated in figure 6-9.

**6-8. EMERGENCY POWER RECEPTACLE.**

a. Removal. Remove the emergency power receptacle as illustrated in figure 6-11.

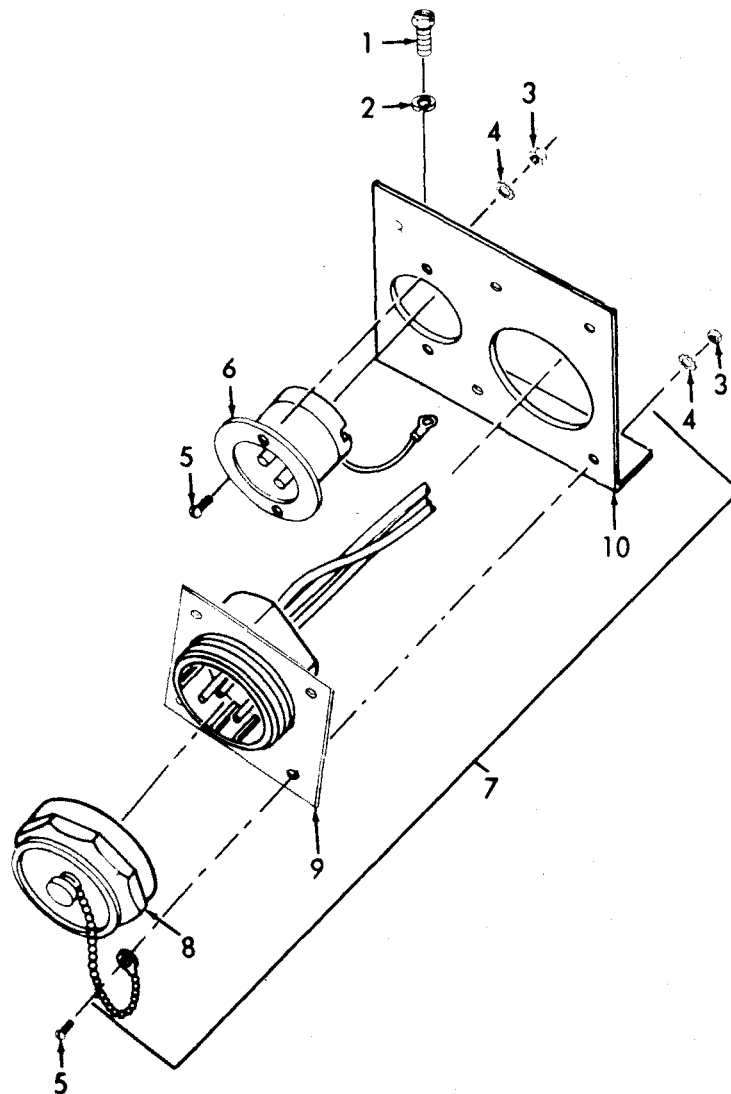


Figure 6-11. Emergency and External Power Receptacle, Removal and Installation.

LEGEND FOR FIGURE 6-11:

ITEM	NSN	P/N	FSCM	QTY
1. Bolt, Machine	5306-00-225-8497	MS90725-32	96906	2
2. Washer, Lock	5310-00-407-9566	MS35338-45	96906	2
3. Nut, Plain	5310-00-934-9747	MS35649-262	96906	3
4. Washer, Lock	5310-00-045-3299	MS35338-43	96906	3
5. Screw	5305-00-889-3000	MS35206-230	96906	3
6. Receptacle	5935-00-660-5207	5278	04009	1
7. Receptacle	5935-00-435-8466	6DW1149	28835	1
8. Cap	5935-00-435-8466	RPE033-011	15235	1
9. Receptacle		RPE333-006PO4N	15235	1
10. Bracket		354012	28835	1

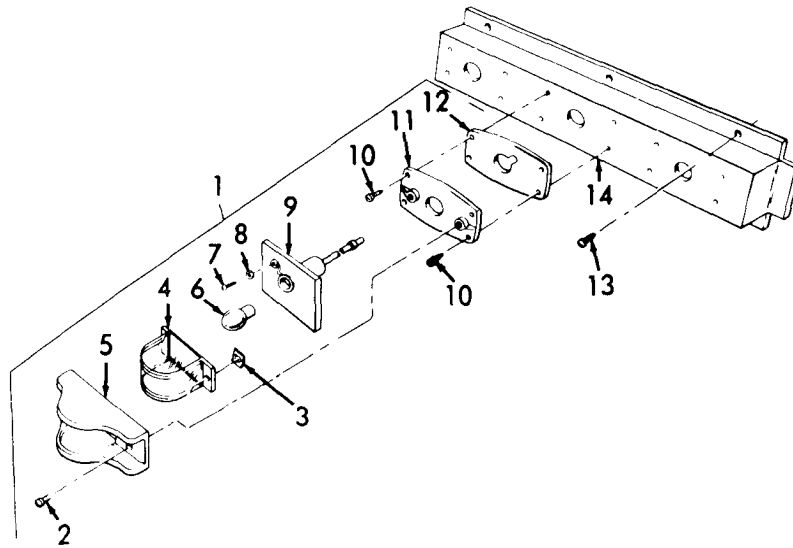
- b. Cleaning and Inspection.
  - (1) Clean metal parts with cleaning solvent and dry thoroughly.
  - (2) Inspect for defective or missing hardware and loose electrical connections.
  - (3) Replace defective or missing hardware and parts as necessary and be sure all electrical connections are clean and secure.
  - (4) Inspect jumper cable for damage and broken or cracked insulation. Replace a defective cable that cannot be repaired.
- c. Installation. Install the emergency power receptacle as illustrated in figure 6-11.

## 6-9. EXTERNAL POWER RECEPTACLE.

- a. Removal.
  - (1) Remove nut that retains the receptacle in the side panel, then remove the receptacle out through rear of the side panel (fig. 6-11).
  - (2) To replace a defective receptacle, tag and unsolder the electrical leads and resolder them to the new receptacle.
  - (3) To remove the receptacle for other purposes, unscrew the knurled knobs that retain the dynamotor hinged control panel in closed position and open control panel. Tag and remove the three electrical leads marked with circuit No. 220, 221, and 222, from the back of terminals L1, L2, and L3, below the emergency receptacle. Then remove the external power receptacle and electrical leads as an assembly.
- b. Cleaning and Inspection.
  - (1) Clean parts with a cloth dampened in cleaning solvent and dry thoroughly.
  - (2) Inspect for defective or missing hardware and loose electrical connections. Replace loose or missing parts and be sure electrical connections are secure.
  - (3) Inspect wiring for breaks or damaged insulation and repair or replace wiring as necessary.
- c. Installation. Install the external power receptacle in reverse order of subparagraph a.

6-10. CLEARANCE LIGHTS.

- a. Removal. Remove the clearance lights as illustrated in figure 6-12.
- b. Cleaning and Inspection.
  - (1) Clean with cleaning solvent and dry thoroughly.
  - (2) Inspect for defective and missing parts or hardware. Replace as necessary.
- c. Installation. Install the clearance lights as illustrated in figure 6-12.



LEGEND FOR FIGURE 6-12:

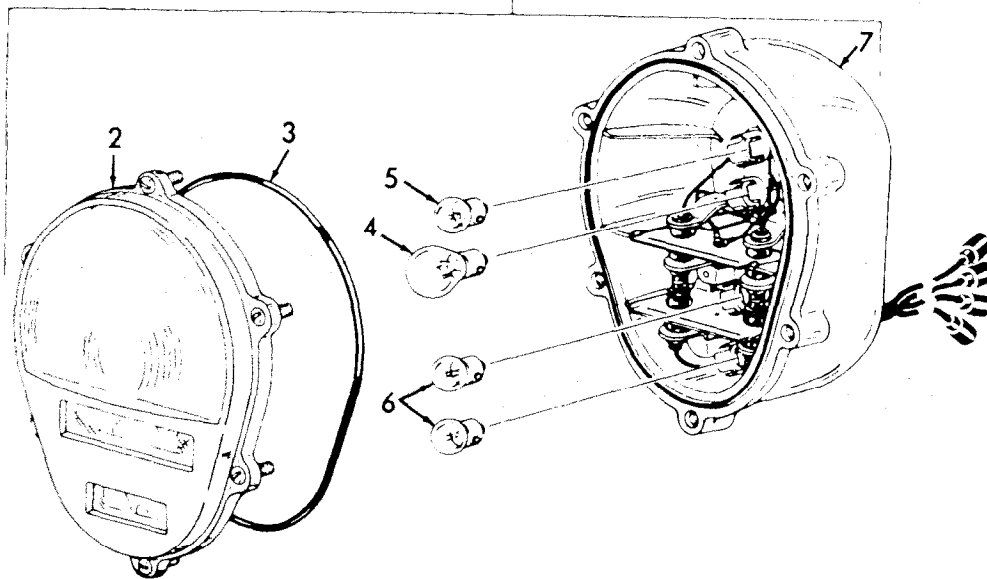
I	NSN	P/N	FSCM	QTY
1. Light, Marker	6220-00-577-3435	MS35424-1	96906	2
1. Light, Marker	6220-00-577-3434	MS35423-1	96906	2
1. Light, Marker	6220-00-726-1916	MS35423-2	96906	5
1. Light, Marker	6220-00-727-3288	MS35424-2	96906	2
2. Screw, Machine	5305-00-984-7361	MS35191-270	96906	2
3. Push On Nut	5310-00-596-8169	7526796	96906	2
4. Lens -Amber	6220-00-752-5992	MS35420-1	96906	1
4. Lens, -Red	6220-00-752-5993	MS35420-2	96906	1
5. Door, Light	6220-00-752-6516	7526516	19207	1
6. Lamp, Incandescent	6240-00-019-0877	MS15570-1251	96906	1
7. Screw, Machine	5305-00-206-3716	MS35214-25	96906	1
8. Washer, Flat	5310-00-045-5205	MS15795-906	96906	1
9. Lampholder	6220-00-729-9295	MS35422-1	96906	1
10. Screw	5305-00-883-0628	MS24617-21	96906	4
11. Plate, Mounting	6250-00-371-4018	7526515	19207	1
12. Felt, Mechanical	5330-00-855-0960	7526509	19207	1
13. Screw	5305-00-855-0960	MS24629-36	96906	8
14. Mount Cluster		13217E1132	59678	1

Figure 6-12. Clearance Lights, Removal and Installation.



**6-11. COMPOSITE LIGHT ASSEMBLY.**

- a. Removal. Remove the composite light assembly by removing the four securing screws and then tag and disconnect the leads.
- b. Disassembly. Disassemble the composite light assembly as illustrated in figure 6-13.
- c. Cleaning and Inspection.
  - (1) Clean with cleaning solvent and dry thoroughly.
  - (2) Inspect for corrosion.
  - (3) Inspect for defective and missing parts or hardware. Replace as necessary,
- d. Assembly. Assemble the composite light assembly as illustrated in figure 6-13.
- e. Installation. Place the composite light assembly into position and secure with four screws. Connect the leads per the tagged identification.



LEGEND FOR FIGURE 6-13:

I		NSN	P/N	FSCM	QTY
1.	Tail Light Assy	6220-00-880-1625	11614157	19207	2
2.	Lens, Light	6220-00-179-4324	11639535	19207	1
3.	Packing, Preformed	5330-00-462-0907	11639519-2	19207	1
4.	Lamp, Incandescent	6240-00-019-3093	MS15570-623	96906	1
5.	Lamp, Incandescent	6240-00-044-6914	MS35478-1683	96906	1
6.	Lamp, Incandescent	6240-00-019-0877	MS15570-1251	96906	2
7.	Body Assy	2510-01-067-4717	11639535	19207	1

Figure 6-13. Composite Light Assembly, Disassembly and Assembly.

**6-12. JUNCTION BOX (24 V CIRCUIT).**

- a. Removal. Remove the junction box as illustrated in figure 6-14.
- b. Cleaning and Inspection.
  - (1) Clean with cleaning solvent and dry thoroughly.
  - (2) Inspect for defective and missing parts or hardware. Replace as necessary.
- c. Installation. Install the junction box as illustrated in figure 6-14.

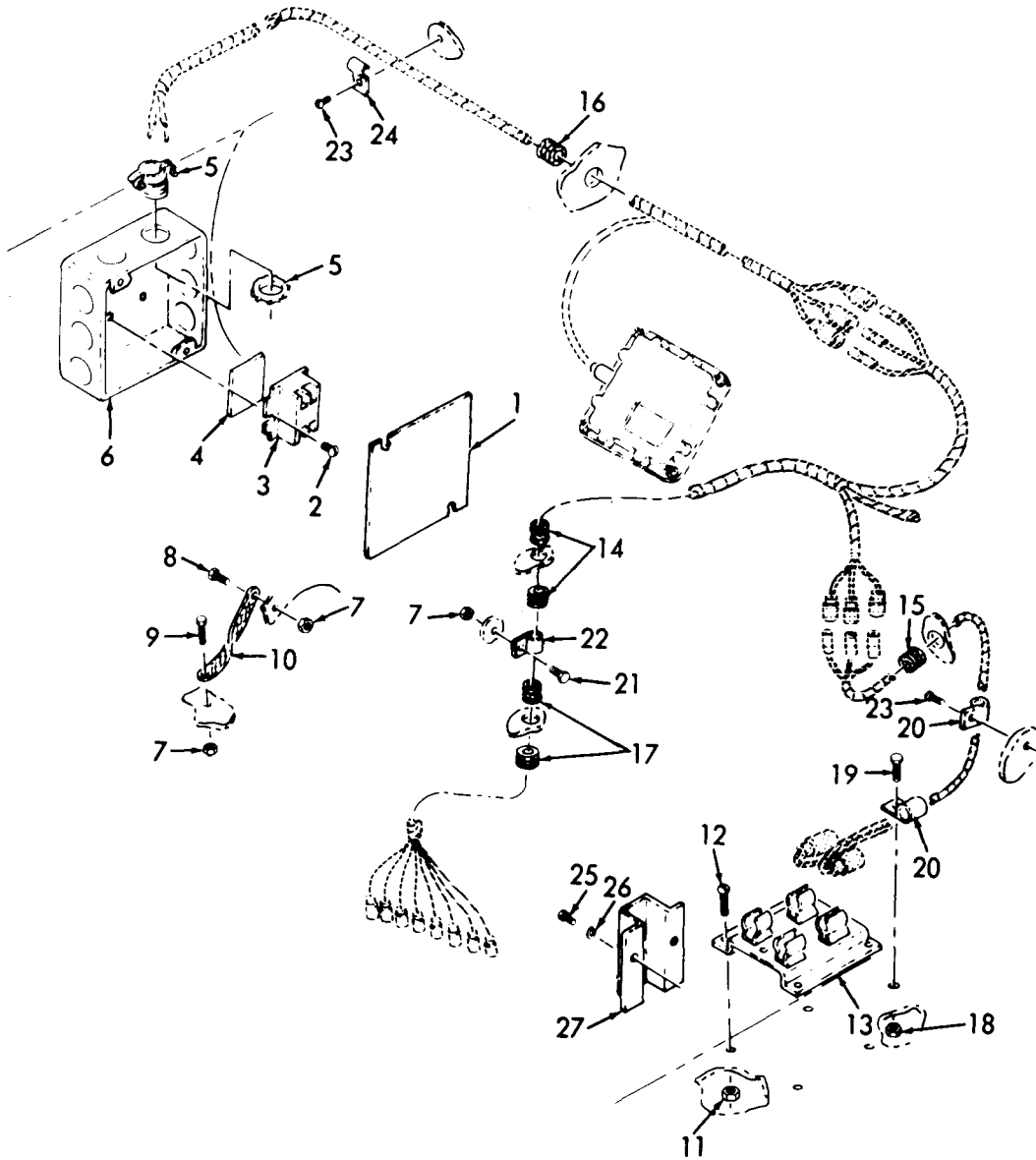


Figure 6-14. Junction Box, Removal and Installation.

## LEGEND FOR FIGURE 6-14:

ITEM	NSN	P/N	FSCM	QTY
1. Cover, Box	5975-00-281-0056	8465	03743	1
2. Screw, Tapping	5305-00-883-6627	MS24617-23	96906	4
3. Board, Terminal	5940-00-891-7446	524	89020	1
4. End Terminal	5940-00-224-9749	530	89020	1
5. Connector, Box	5975-00-199-9563	13218E0003-1	97403	3
6. Box Junction	5975-00-194-8878	4S1-2	03743	1
7. Nut Self-Locking	5310-00-088-1251	MS51922-1	96906	12
8. Screw, Cap	5305-00-225-3839	MS90725-8	96906	2
9. Screw, Cap	5305-00-068-0500	MS90725-3	96906	6
10. Lead Assy	2590-01-056-3637	13217E0913	59678	4
11. Nut Self-Locking	5310-00-208-4026	MS20500-1032	96906	8
12. Screw, Machine	5305-00-989-7434	MS35207-263	96906	8
13. Clip, Assy	5340-01-048-2239	10935126	19207	2
14. Grommet, Rubber	5325-00-959-2089	MS35490-17	96906	2
15. Grommet, Rubber	5325-00-838-1992	MS35490-68	96906	2
16. Grommet, Rubber	5325-00-276-6098	MS35489-78	96906	1
17. Grommet	5325-00-763-2916	13217E0914	59678	2
18. Nut Self-Locking	5310-00-440-9912	MS51988-2	96906	6
19. Screw, Machine	5305-00-989-7435	MS35207-264	96906	6
20. Clamp, Loop	5340-00-057-2904	MS21333-71	96906	8
21. Screw, Cap	5305-00-068-0501	MS90725-5	96906	4
22. Clamp, Loop	5340-00-809-1494	MS21333-105	96906	4
23. Screw, Tapping	5305-00-855-0957	MS24269-46	96906	14
24. Clamp, Loop	5340-00-764-7051	MS21333-69	96906	12
25. Screw, Cap	5305-00-269-3208	MS90725-57	96906	4
26. Washer, Lock	5310-00-637-9541	MS35338-46	96906	8
27. Guard, Terminal		13217E1017	59678	2

6-13. REAR WIRING TO FLOODLIGHT.

- a. Removal. Remove the rear wiring to the floodlight as illustrated by 6-15.
- b. Cleaning and Inspection.
  - (1) Clean with cleaning solvent and dry thoroughly.
  - (2) Inspect for defective and missing parts or hardware. Replace as necessary.
- c. Installation. Install the rear wiring to the floodlight as illustrated by figure 6-15.

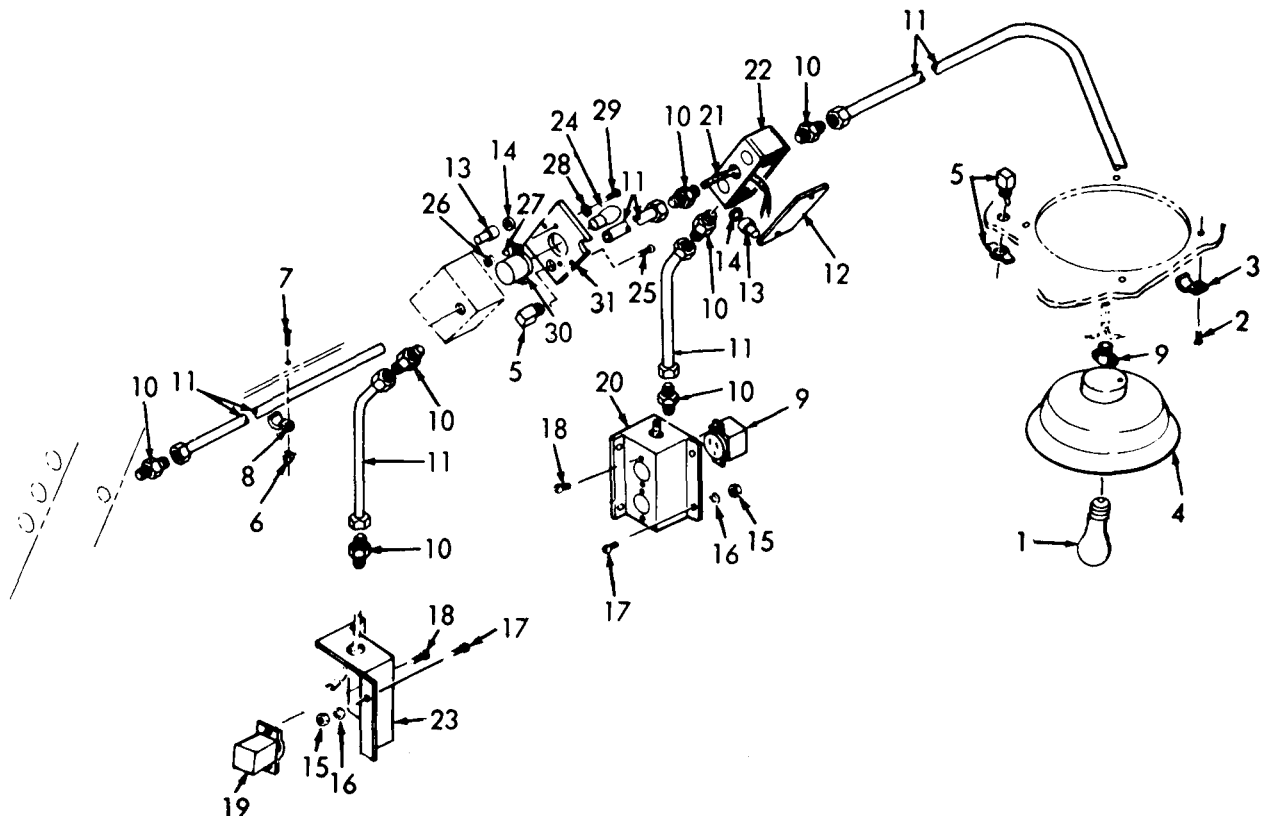


Figure 6-15. Rear Wiring to Floodlight, Removal and Installation.

## LEGEND FOR FIGURE 6-15:

ITEM	NSN	P/N	FSCM	QTY
1. Lamp, Incandescent	6240-00-143-7493	W-L-101/84	81348	2
2. Screw, Machine	5305-00-432-4170	MS51861-35	96906	6
3. Retainer, Lamp	5340-00-405-6170	13217E1154	59678	6
4. Fixture, Light	6210-00-470-3316	13217E1074	59678	2
5. Switch, Toggle	5930-00-198-3938	13217E1013	59678	2
6. Nut Self-Locking	5310-00-088-1251	MS51922-1	96906	8
7. Screw, Machine	5305-00-988-1723	MS35206-279	96906	8
8. Strap, Retaining	5340-00-664-9175	MS35140-10	96906	8
9. Connector, Box		13217E1070	59678	1
10. Bushing, Elec.	5975-00-100-8706	WF408	81348	14
11. Condu	5975-00-178-1216	WW-C-563	81348	1
12. Plate, Wall	5975-00-280-7921	2540	03743	2
13. Cap, Splice	4940-01-124-5126	13217E0942-1	59678	35
14. Insulator, Splice	5940-00-871-8799	13217E0943-1	59678	35
15. Nut Plain	5310-00-934-9758	MS35649-202	96906	8
16. Washer, Lock	5310-00-596-7691	MS35335-32	96906	28
17. Screw, Machine	5305-00-984-6210	MS35206-263	96906	10
18. Screw, Machine	5305-00-984-6191	MS35206-243	96906	16
19. Receptacle		13217E1216	59678	14
20. Box Electrical		13217E1138	59678	1
20. Box Electrical		13217E1139	59678	1
21. Wiring Harness		13217E0922-1	59678	1
22. Junction Box	5975-00-153-6396	WJ800STYLE25- SZJTY3	81348	2
23. Box Electrical		13217E1137	59678	1
23. Box, Electrical		13217E1136	59678	1
24. Lamp, Incandescent	6240-00-246-5052	MS15541-2	96906	2
25. Screw	5305-00-879-7941	MS24617-31	96906	4
26. Nut, Plain	5310-00-934-9747	MS35649-262	96906	4
27. Washer, Lock	5310-00-209-0788	MS35335-30	96906	4
28. Washer, Flat	5310-00-983-8483	MS27183-5	96906	4
29. Screw, Machine	5305-00-889-3000	MS35206-230	96906	4
30. Socket, Light	6250-00-478-9061	13217E1224	96906	6
31. Cover	6250-00-229-9003	13217E1181	59678	2



## CHAPTER 7

ENGINE ELECTRICAL SYSTEM

---

**7-1. GENERAL.** The engine electrical system consists of two 12-volt, 100 amp-hour, lead-acid type batteries connected in series; a 24-volt heavy duty starting motor consisting of a starting motor, a solenoid, and a drive assembly; and a battery charging alternator with an integral voltage regulator.

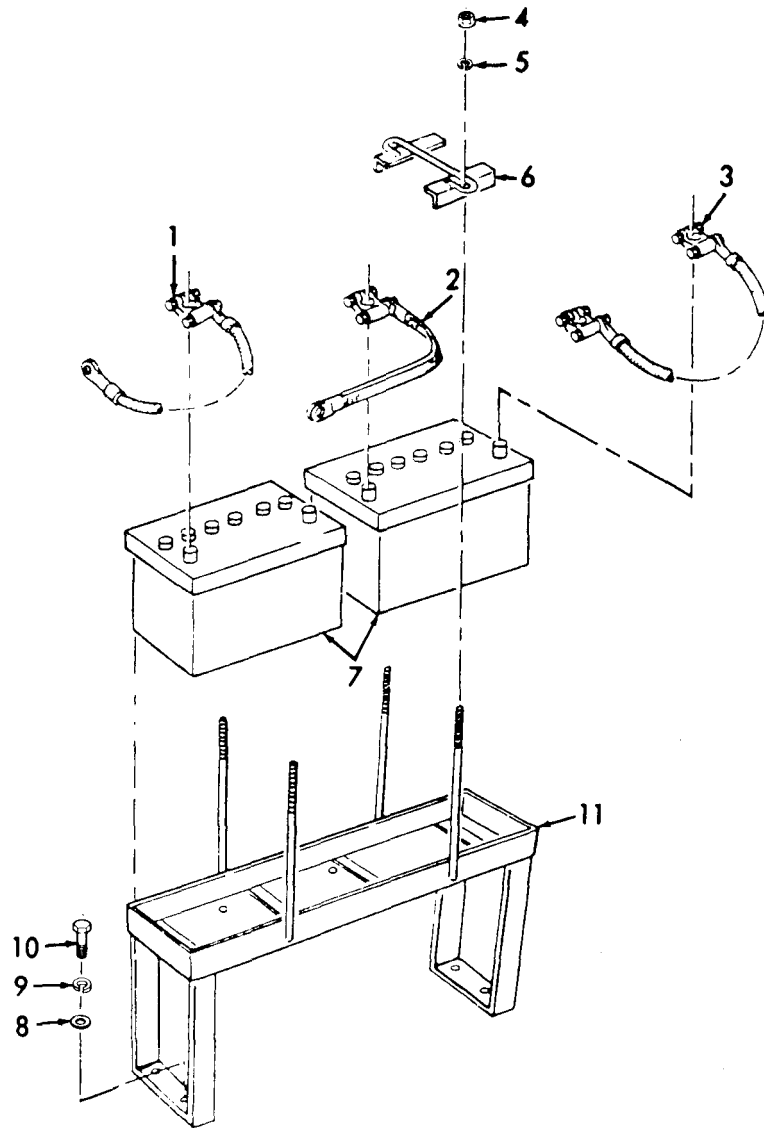
**7-2. BATTERIES.**a. Removal.

- (1) Be sure that all power switches are set to off.
- (2) Refer to figure 7-1 and remove the batteries and the battery box (if required).

b. Cleaning, Inspection, and Service.

- (1) Clean all corrosion from battery terminals and cases with a wire brush.
- (2) Inspect the battery cases for cracks, and terminals for loose mounting.
- (3) Check the battery electrolyte per tables 7-1 and 7-2.
- (4) When the battery leads are installed, coat the exposed areas of the terminal with a thin coat of grease to prevent corrosion.

c. Installation. Refer to figure 7-1 and install the battery box (if removed) and the batteries.



LEGEND FOR FIGURE 7-1:

ITEM	NSN	P/N	FSCM	QTY
1. Cable		SW12507P1	98255	1
2. Cable		SW12507P2	98255	1
3. Cable		SW12508P	98255	1
4. Nut, Plain	5310-00-577-2686	50MS732-0	28835	4
5. Washer, Flat	5310-00-821-7538	W11242-5	28835	4
6. Hold-down, Battery		358700	28835	2
7. Battery	6140-00-057-2554	MS35000-3	96906	2
8. Screw, Cap	5305-01-038-9546	W11100-1	28835	4
9. Washer, Lock	5310-00-487-1273	W11254-8	28835	4
10. Washer, Flat	5310-00-476-5229	W11242-12	28835	4
11. Box, Battery		358690	28835	1

Figure 7-1. Batteries and Battery Box, Removal and Installation.



**Table 7-1.** State of Charge with Specific Gravity Corrected to 80°F.

Specific Gravity	Percent Charge
1.280	100
1.250	75
1.220	50
1.190	25
1.160	Little Useful Capacity
1.130	Discharged

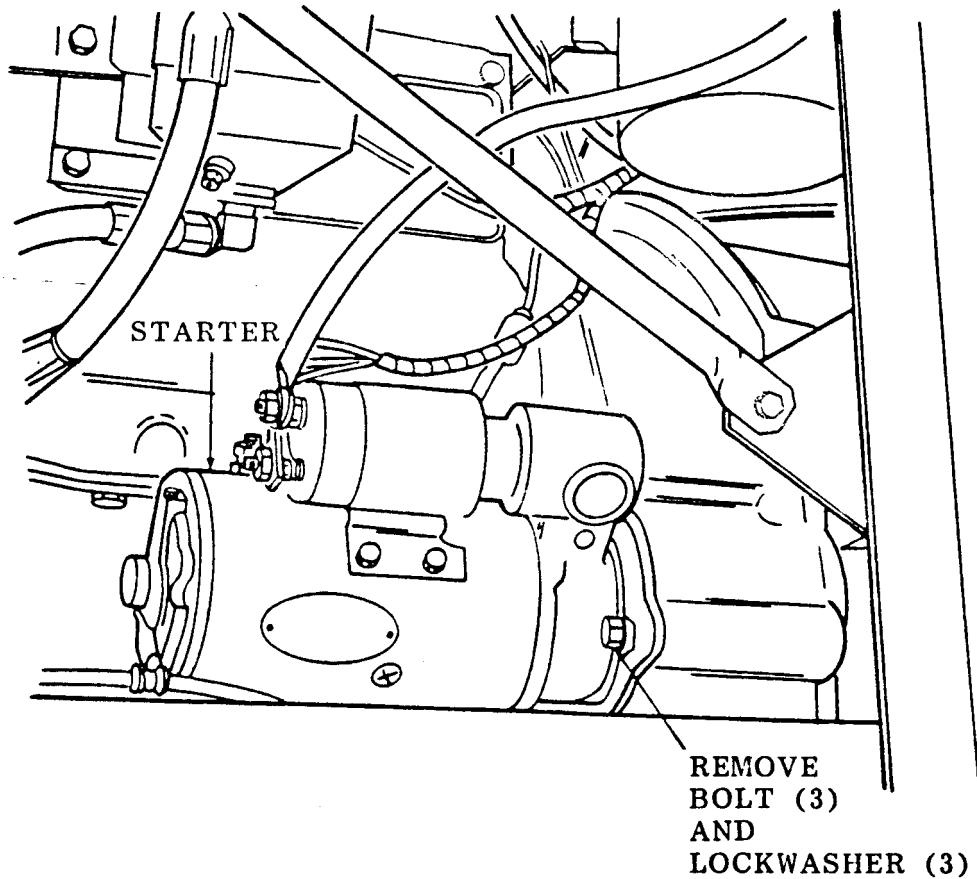
**Table 7-2.** Specific Gravity Temperature Corrections

Temperature	Correction Factor
±120	±0.016
±115	±0.014
±110	±0.012
±105	±0.010
±100	±0.008
±95	±0.006
±90	±0.004
±85	±0.002
±80	0
±75	-0.002
±70	-0.004
±65	-0.006
±60	-0.008
±55	-0.010
±50	-0.012
±45	-0.014
±40	-0.016
±35	-0.018
±30	-0.020
±25	-0.022
±20	-0.024
±15	-0.026
±10	-0.028
±5	-0.030
0	-0.032
-5	-0.034
-10	-0.036
-15	-0.038
-20	-0.040

**7-3. STARTER ASSEMBLY.**

a. Removal (Refer to figure 7-2).

- (1) Disconnect battery leads.
- (2) Tag and disconnect electrical leads from starter assembly.
- (3) Remove three bolts, three lockwashers, and the starter assembly.



**NOTE:** TAG AND DISCONNECT ELECTRICAL LEADS.

Figure 7-2. Starter Assembly, Removal and Installation.

b. Disassembly (Refer to Figure 7-3).

- (1) Remove nut (1), lockwasher (2), and terminal lead (3) .
- (2) Remove screws (4) to remove solenoid assembly (5) from starter assembly.
- (3) Remove nut (6), flat washer (7), and insulating washer (8).
- (4) Remove nut (9), lockwasher (10), nut (11), flat washer (12), and insulating washer (13).
- (5) Remove screws (14) and flat washers (15) to remove cover (16) and gasket (17) from frame assembly (18). Discard gasket.
- (6) Remove nuts (19) and lockwashers (20) to remove terminal stud (21).
- (7) Remove spring (22) and contact assembly (23).
- (8) Remove plug (24), retaining ring (25), pin (26), and boot clamp (27 ) to remove plunger (28).
- (9) Remove retaining ring (29) to remove spring retainer (30), spring (31), boot (32), spring retainer (33), and retaining ring (34) from plunger (28).
- (10) Remove bolts (35) and lockwashers (36) to remove commutator end frame (37), packing (38), and spacer washer (39).
- (11) Remove plug (40) and oil wick (41).
- (12) Remove pin (42) to remove brush spring (43) and brushholders (44).
- (13) Remove screws (43), electrical leads (46), and brushes (47) from brushholders (44).
- (14) Carefully slide armature (48) from housing (49).
- (15) Remove nut (50), flat washer (51), and insulator (52).
- (16) Remove screws (53), pole shoes (54), field coil assembly (55), and insulator (56).
- (17) Remove screws (57) and lockwashers (58) to remove drive housing (59) and gasket (60). Discard gasket.
- (18) Remove plug (61) and oil wick (62).
- (19) Do not remove bushing (63) unless inspection reveals defects.

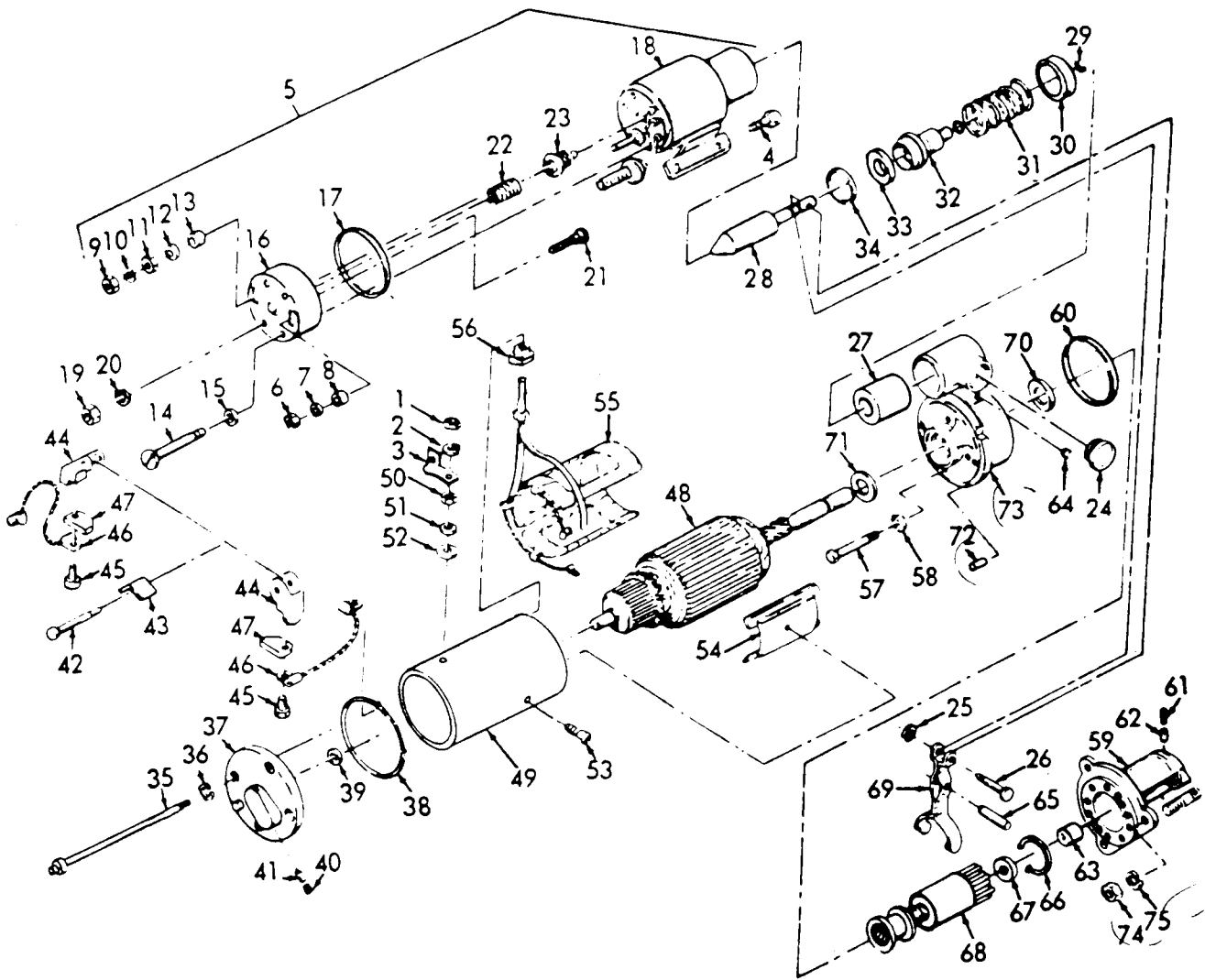


Figure 7-3. Starter, Disassembly and Assembly.

## LEGEND FOR FIGURE 7-3:

ITEM	NSN	P/N	FSCM	QTY
1. Nut, Plain	5310-00-268-7271	1904419	16764	1
2. Washer, Lock	5310-00-373-0373	9421425	16764	1
3. Connector		1942249	16764	1
4. Screw, Cap	5306-00-335-4376	1917084	16764	4
5. Switch Assy. Solenoid	2920-00-064-8946	1115505	16764	1
6. Nut, Plain	5310-00-482-8512	9415318	16764	1
7. Washer, Lock	5310-00-045-3296	453296	16764	1
8. Washer	5310-00-058-5269	1950064	16764	1
9. Nut, Plain	5310-00-482-8512	9415318	16764	1
10. Washer, Lock	5310-00-045-3296	453296	16764	1
11. Nut	5310-01-013-5787	1949671	16764	1
12. Washer	5310-00-702-1797	WP6	56878	1
13. Washer	5310-00-058-5269	1950064	16764	1
14. Screw, Machine	5305-01-017-1574	45364	16764	2
15. Washer, Flat	5310-00-167-0834	1923935	16764	2
16. Cover		1962538	16764	1
17. Gasket	5330-00-061-8358	1965625	16764	1
18. Case and Coil Assy		1962532	16764	1
19. Nut, Plain		453433	16764	1
20. Washer, Lock	5315-00-011-0409	MS35338-46	96906	1
21. Stud, Terminal		1958751	16764	1
22. Spring, Contact	5360-00-969-0541	1917128	16764	1
23. Contact and Push Rod	2920-00-722-6662	1917119	16764	1
24. Plug, Expansion		9419572	16764	1
25. Ring, Snap		1938376	16764	1
26. Pin, Straight		1942253	16764	1
27. Bushing, Sleeve		1933999	16764	1
28. Plunger Assy.		1948682	16764	1
29. Ring, Retaining	5365-00-715-1152	9415235	16764	1
30. Washer, Recessed	5310-00-822-2241	1948526	16764	1
31. Spring, Helical	5360-00-812-0196	1948521	16764	1
32. Bellows	2920-00-839-1864	1949618	16764	1
33. Washer, Recessed		1948687	16764	1
34. Washer, Recessed	5310-00-822-2236	1948520	16764	1
35. Bolt	5306-00-273-6722	809763	16764	2
36. Washer, Lock	5310-00-407-9566	9421424	16764	2
37. Frame, End		1946316	16764	1
38. Packing		1916272	16764	1
39. Washer, Flat	5310-00-178-9612	1914842	16764	1
40. Plug		H53465	16764	1
41. Wick	2920-00-865-8270	1916439	16764	1
42. Pin		1938058	16764	1
43. Spring	5360-00-733-9916	1946322	16764	1
44. Holder, Brush		1940477	16764	2
45. Screw and Washer	5305-00-900-8496	1959514	16764	4
46. Lead		1930695	16764	1
47. Brush	5977-00-733-9909	1906990	16764	4
48. Armature	2920-00-902-7878	1932872	16764	1

LEGEND FOR FIGURE 7-3 (Continued):

49.	Housing	Part of Item #73			1
50.	Nut, Plain	5310-00-732-0558	MS51967-8	96906	1
51.	Washer, Flat	5310-00-441-5473	6087	19315	1
52.	Washer, Insulation	5310-00-902-1124	1950029	16764	1
53.	Screw, Machine	5305-00-450-5937	1968396	16764	4
54.	Shoe, Pole		1931784	16764	4
55.	Coil Assy.		1951857	16764	1
56.	Bolt	5306-00-902-2725	1962546	16764	4
57.	Bushing		1931783	16764	1
58.	Washer, Lock	5310-00-407-9566	9421424	16764	4
59.	Housing		1947803	16764	1
60.	Packing, Preformed		1916272	16764	1
61.	Plug		453465	16764	1
62.	Wick	2920-00-865-8270	1916439	16764	1
63.	Bushing		1955994	16764	1
64.	Plug, Expansion		9417272	16764	1
65.	Shaft		1948688	16764	1
66.	Ring, Retainer	5365-00-804-9666	1928022	16764	1
67.	Collar		1928021	16764	1
68.	Clutch, Motor		1941157	16764	1
69.	Lever		1948690	16764	1
70.	Washer, Flat		821453	16764	1
71.	Washer, Flat		1942283	16764	1
72.	Pin, Dowel		809593	16764	1
73.	Housing		1948693	16764	1
74.	Nut, Plain	5310-00-732-0559	MS51968-8	96906	3
75.	Washer, Lock	5310-00-061-1258	201706A	28265	3
76.	Stud	5307-01-071-3436	201898-A	28265	3
77.	Starter Assy.	2920-00-436-3150	1113204	16764	1

(20) Remove plug (64) to remove pivot pin (65).

(21) Remove retaining ring (66) and retainer (67).

(22) Rotate clutch assembly (68) counterclockwise to remove the shaft off the armature.

(23) Remove shift lever (69), but do not remove bushings (70 and 71) or guide pin (72) from shifter housing (73) unless inspection reveals defects.

(24) Remove nuts (74), and lockwashers (75).

c. Cleaning, Inspection, and Repair.**CAUTION**

Do not use dry cleaning solvent to clean electrical parts.

- (1) Clean all metal non-electrical parts in an approved solvent and dry thoroughly with filtered compressed air.

**CAUTION**

When cleaning field coils, use extreme care to avoid damaging protective insulation.

- (2) Clean field coils with a clean, lint-free cloth lightly moistened with an approved solvent and dry thoroughly with filtered compressed air.
- (3) Remove loose particles from armature with filtered compressed air and wipe clean with a cloth lightly moistened with an approved solvent. Clean commutator lightly with No. 100 grit sand- (NSN -5350-00-559-7781) . Remove all traces of dust with low pressure compressed air.
- (4) Clean non-metallic washers, insulators, and seats with a clean, lint-free cloth lightly moistened with an approved solvent.

**CAUTION**

Do not allow solvent to contact brushes.

- (5) Clean brushes with a clean, lint-free cloth.
- (6) Inspect housings and frames for cracks, corrosion, and distortion. Replace defective parts.
- (7) Inspect bushings for wear, galling, and scoring. Replace defective parts.
- (8) Test armature for grounding as follows:
  - (a) Connect one lead of a test light to the armature core.
  - (b) Touch the other test lead to each commutator riser.
  - (c) If test light glows, armature is grounded and must be replaced.

- (9) Test armature for short circuits as follows:
  - (a) Place armature on a growler fixture.
  - (b) Activate the fixture and slowly rotate the armature while touching the armature lightly with a steel strip.
  - (c) Strip will vibrate against armature over a shorted area.
  - (d) Replace armature if a short is indicated.
- (10) Turn down commutator if scored or out of round. Under cut mica to a depth of 0.025 to 0.032 inch below surface of commutator.

#### NOTE

Check diameter of commutator after removing material. Diameter shall not be less than 1.6470 inches.

- (11) Use an ohmmeter to check field coils for insulation breakdown as follows:
  - (a) Attach one lead to field housing and the other to field coil terminal.
  - (b) Replace field coil if a reading of less than 1 megohm is indicated.
- (12) Inspect drive assembly for badly worn or broken teeth. Check internal spline for wear and damage. Check spring for cracks, breaks, and distortion. Replace drive assembly if defective.
- (13) Inspect brushholders and support for cracks, corrosion, and other damage. Replace defective parts.
- (14) Measure brush length. Replace brushes if length is 5/16-inch or less.
- (15) Test brush spring tension with a spring tester. Tension shall be 36 to 40 ounces. Replace brush springs if tension is less than specified.
- (16) Inspect all threaded parts for crossed, stripped, or peened threads. Replace damaged parts.
- (17) Using an ohmmeter, test for continuity across terminals of solenoid case and coil. There shall be no sign of open circuit.
- (18) Check solenoid case and coil for grounding by touching one lead of ohmmeter to either lead and the other to the frame casing. There shall be no sign of continuity.



(19) Smooth scratches, burrs, and nicks on any machined surfaces using a fine file. Remove all fillings before assembly.

(20) Repair minor thread damage using thread chasers, taps, and dies. Clean threads to remove metal particles.

d. Assembly (Refer to figure 7-3).

(1) Assemble starter assembly in reverse order of disassembly using new gaskets.

(2) If brushes were replaced, run in new brushes as follows:

(a) Cover armature commutator with a piece of No.100 grit sandpaper (NSN 5350-00-559-7781).

(b) Temporarily install brushes and commutator end frame and run in brushes by operating motor for ten minutes.

(c) Disassemble, remove sandpaper, and clean armature commutator and brushholder assembly with filtered compressed air.

e. Testing.

(1) Test overrun clutch as follows:

(a) Rotate drive gear back and forth. Gear should turn freely in direction of motor rotation and rotate armature shaft in other direction.

(b) If gear turns armature shaft in both directions, the overrun clutch is binding and must be replaced.

(c) If gear does not rotate armature shaft in either direction, the overrun clutch is slipping and must be replaced.

(2) Test starter solenoid as follows:

(a) Remove terminal lead.

(b) Apply 24 Vdc between the negative terminal and the small terminal of the solenoid assembly.

(c) Solenoid actuation will be indicated by an audible "click" and rearward movement of the drive gear.

(d) Remove 24 Vdc from solenoid assembly terminals.

(e) The drive gear should move forward with an audible "click".

(f) Replace solenoid assembly if it fails to function.

(g) Install terminal lead.

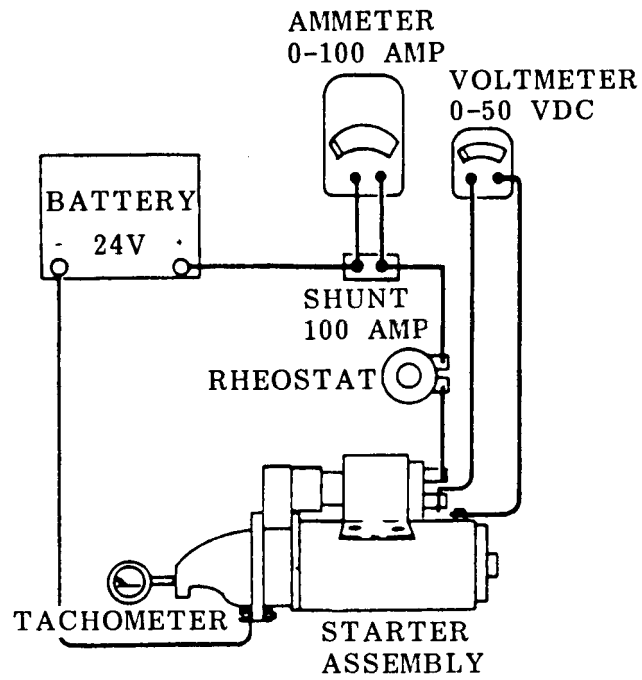


Figure 7-4. Starter Assembly Motoring Test Circuit.

(3) Conduct starter assembly motoring test as follows:

- (a) Remove terminal lead between solenoid and starter motor.
- (b) Install starter into motoring test circuit shown in figure 7-4.
- (c) Adjust rheostat until voltmeter indicates 20-volts.
- (d) Check indications of ammeter and tachometer.
- (e) Ammeter should indicate 50 to 70 amps with starter turning at 7,000 to 9,500 rpm.
- (f) If current and speed are low, disassemble starter and check for high resistance at internal connections.
- (g) If current is high and rpm low, disassemble and inspect armature shaft and bushings for wear or misalignment.
- (h) Do not install terminal lead until after performing the torque test.

f. Installation. Refer to figure 7-2 and install the starter in the reverse order of removal.

#### 7-4. ALTERNATOR.

a. Removal (Refer to figure 7-5).

- (1) Tag and disconnect the electrical connection.
- (2) Loosen the mounting hardware and remove the V-belt (8).
- (3) Remove adjusting arm screw (1) and washers (2 and 3).
- (4) Remove the mounting bracket screw (6), spacer (7), washers (5), and nut (4).

b. Disassembly (Refer to figure 7-6).

- (1) Remove screw (35), and screw (32).
- (2) Ease cover (36) away from alternator.
- (3) Tag and disconnect wiring. Reinstall nuts and studs.
- (4) Remove cover (36) and OVV absorber (34).
- (5) If necessary, remove fuse (39), fuseholder (4), connector (37) and terminal leads (41 through 44).
- (6) Remove screw (32) and housing and shield (33).

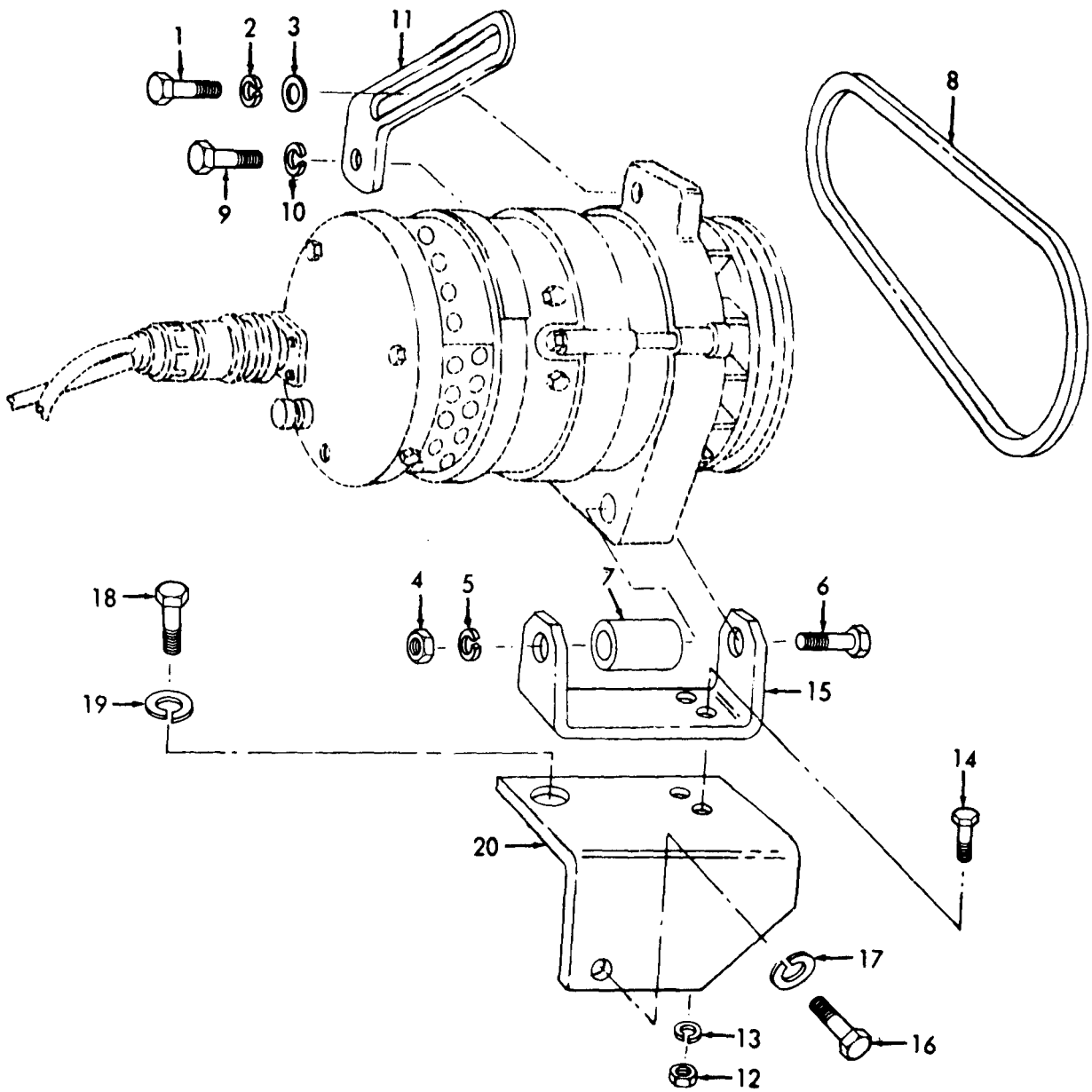


Figure 7-5. Alternator, Removal and Installation.

- (7) Remove nut (29), washer (30), and sleeve (31).
- (8) Remove diode assembly (26). If necessary, remove nut (27) and lockwasher (28).
- (9) Remove two screws (25), and regulator (25).
- (10) Tag and disconnect regulator wiring. Reinstall hardware.
- (11) Remove lead (22), two screws (21), and brush assembly (20).
- (12) Remove nut (38) and five insulated washers (14).
- (13) Remove four nuts (5), four bolts (23), and separate rear housing (19).
- (14) Remove two diode assemblies (10) and (11).
- (15) Remove stator assembly (9).
- (16) Remove bearing (17) and retainer (18).
- (17) Remove nut (45), lockwasher (2), pulley (3), key (13), and fan (4).
- (18) Remove rotor (16).
- (19) Remove spacer (15), snap ring (8), and bearing (7).

c. Cleaning, Inspection, and Repair.

- (1) Clean all non-electrical parts in an approved solvent and dry.
- (2) Clean all electrical parts with a soft bristled brush.
- (3) Inspect plate and rectifier assemblies for cracks, corrosion, and evidence of shorting or other damage.
- (4) Using an ohmmeter or similar testing device, test positive diode rectifier assembly as follows:
  - (a) Connect positive lead of tester to heat sink and touch negative lead to each diode. Tester should indicate open circuit at each diode.
  - (b) Connect negative lead to heat sink and touch positive lead to each diode lead. Tester should indicate continuity at each diode.
  - (c) Replace positive diode rectifier assembly if any of the diodes fail to test correctly.

LEGEND FOR FIGURE 7-5:

ITEM	NSN	P/N	FSCM	QTY
1. Screw, Cap	5305-00-137-3312	201558A	28265	1
2. Washer, Lock	5310-00-198-3746	2012-04021	28265	1
3. Washer, Flat	5310-01-077-9752	2000-04021	28265	1
4. Nut	5310-00-605-6259	201426A	28265	1
5. Washer	5310-00-275-9266	29-30-50	80280	1
6. Screw, Cap	5305-01-077-9916	1000-17231	28265	1
7. Spacer		40-0023101A	28265	2
8. Belt, V	3030-00-528-6795	1563508	28265	1
9. Screw		3452A	28265	1
10. Washer		2012-04023	28265	1
11. Strap		40-00197128	28265	1
12. Nut		1500-02222	28265	2
13. Washer		2012-04022	28265	2
14. Screw, Cap	5305-01-077-8643	1000-12150	28265	2
15. Bracket		40-0020525C	28265	1
16. Screw, Cap	5305-00-728-0213	205626A	28265	1
17. Washer, Lock	5310-00-011-6124	MS35338-70	96906	1
18. Screw, Cap	5305-01-077-9915	1000-12290	28265	1
19. Washer, Lock	5305-00-077-9915	2012-04024	28265	1
20. Bracket		40-0020524C	28265	1

(5) Test negative diode rectifier assembly as follows:

(a) Connect negative lead to lead of each diode and positive lead to heat sink. Tester should indicate open circuit at each diode.

(b) Connect positive lead of tester to heat sink and touch negative lead to each diode lead. Tester should indicate continuity at each diode.

(c) Replace negative diode rectifier assembly if any diode fails to test correctly.

(6) Visually inspect stator assembly for rub marks on the interior diameter, evidence of burned or shorted windings, and other damage.

(7) Using an ohmmeter, check continuity of each phase of stator assembly. Replace stator assembly if ohmmeter indicates open circuit of one or more phase.

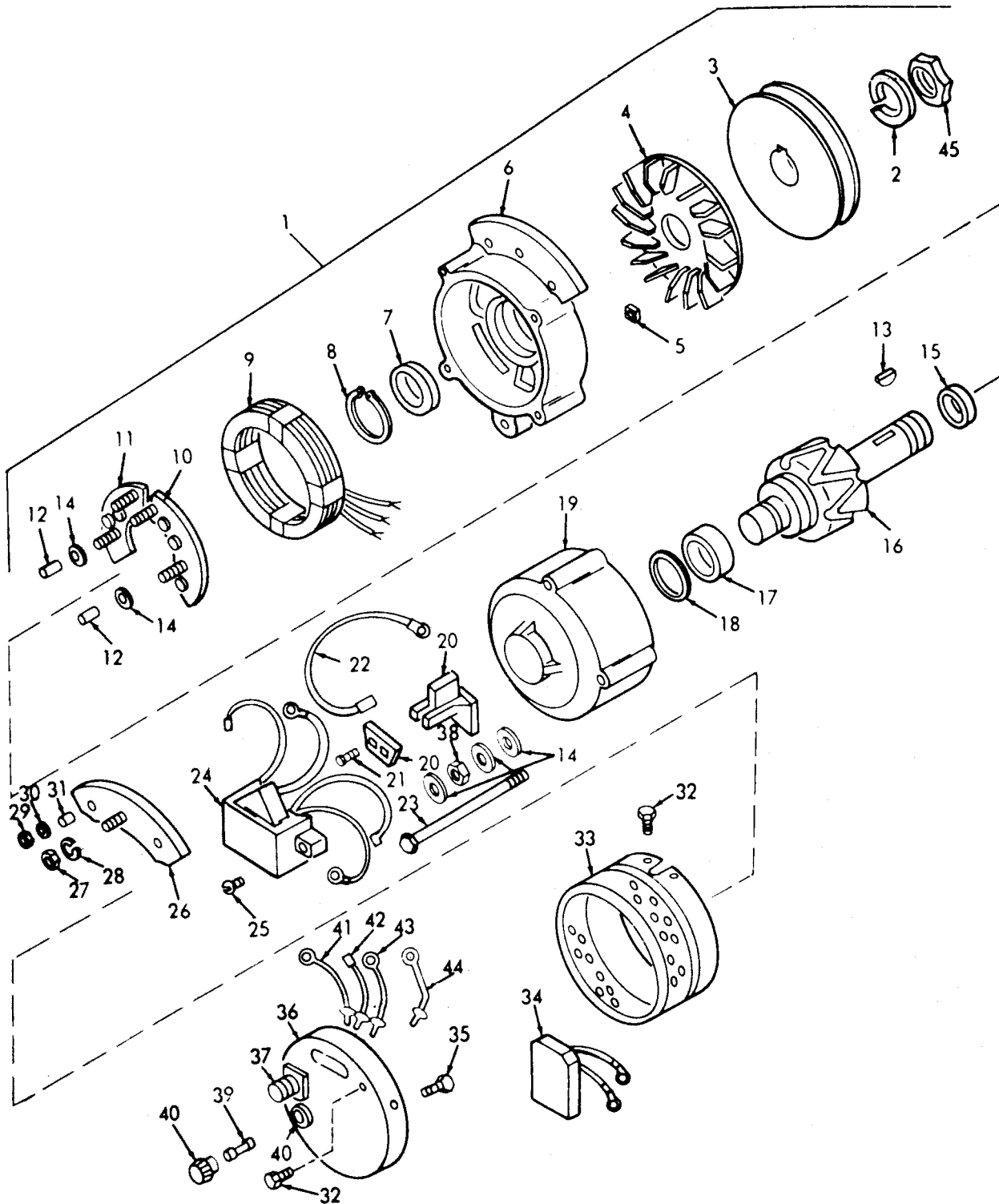


Figure 7-6. Alternator, Disassembly and Assembly.

## LEGEND FOR FIGURE 7-6:

ITEM	NSN	P/N	FSCM	QTY
1. Alternator Assy.	2920-00-118-1222	70D44672802	31211	1
2. Washer, Lock	5310-00-436-1975	20-5	31211	1
3. Pulley	3020-00-207-9284	7-75	31211	1
4. Fan		7-8	31211	1
5. Nut		20-3	31211	4
6. Housing, Front		14-1	31211	1
7. Bearing, Front	3110-00-123-2583	11-42	31211	1
8. Retainer, Front		11-3	31211	1
9. Stator Assy.	6105-00-105-8290	13-5	31211	1
10. Diode Assy.	5961-00-136-4145	1-10	31211	1
11. Diode Assy.	5961-00-136-4146	1-11	31211	1
12. Sleeve	5340-00-110-5679	15-1	31211	1
13. Key, Woodruff	5315-00-133-3625	20-7	31211	1
14. Washer, Insulat.	5970-00-148-6300	15-3	31211	5
15. Spacer		20-92	31211	1
16. Rotor	2920-00-133-9888	12-25	31211	1
17. Bearing, Rear	3110-00-130-7718	11-41	31211	1
18. Retainer, Rear		11-25	31211	1
19. Housing, Rear	2920-00-764-7914	14-35	31211	1
20. Brush Assy.	2925-00-927-1460	3-2	31211	1
21. Screw, Tapping	5305-00-132-7816	20-32	31211	2
22. Cable, Lead	5995-00-248-4020	16-79	31211	1
23. Bolt		20-2	31211	4
24. Regulator Assy.	5905-00-401-6563	5-58	31211	1
25. Screw, Tapping	5305-00-026-2597	20-99	31211	2
26. Diode Assy.	5961-00-484-3034	1-65	31211	1
27. Nut, Plain	5310-00-224-0488	20-81	31211	1
28. Washer, Lock	5310-00-216-8392	20-62	31211	1
29. Nut, Plain	5310-00-132-1527	20-33	31211	1
30. Washer	5970-00-144-7307	15-4	31211	1
31. Insulator Bushing	5970-00-436-5271	15-2	31211	1
32. Screw, Tapping	5305-00-026-2577	20-121	31211	1
33. Housing and Shield		14-33	31211	1
34. Absorber, OVV	5920-00-106-1454	9-11	31211	1
35. Screw, Tapping	5305-00-026-2577	20-121	31211	1
36. Cover Assy.		14-34	31211	1
37. Connector	5935-00-827-1333	MS3102R18-55	96906	1
38. Nut, Plain	5310-00-020-4737	20-34	31211	1
39. Fuse, 40 Amp		2-9	31211	1
40. Receptacle Assy.	5920-00-450-8921	2-8	31211	1
41. Connector, Lead		16-80	31211	1
42. Connector, Lead	5977-00-760-6432	16-82	31211	1
43. Connector, Lead	2920-00-401-4282	16-81	31211	1
44. Connector, Lead		16-93	31211	1
45. Nut, Plain	5310-00-132-1526	20-4	31211	1



- (8) Visually inspect rotor assembly for rub marks and burns or other evidence of shorting. Inspect shaft for worn key slot and bearing surfaces.
- (9) Test rotor assembly as follows:
  - (a) Install rotor assembly in test set-up as shown in figure 7-7.
  - (b) Adjust rheostat until voltmeter indicates 20-Vdc.
  - (c) Ammeter should indicate 1.28 to 1.88 amperes at 70° to 80°F (21.1° to 26.7°C).
  - (d) High current indication on ammeter indicates excessive internal resistance in rotor assembly.
  - (e) Using an ohmmeter, check resistance across slip rings. Resistance should be 11.0 to 14.0 ohms at ambient temperature of 70° to 80°F (21.1 to 26.7°C).
- (10) Replace rotor assembly if inspection and test requirements are not met.
- (11) Inspect voltage regulator connector and cover assembly for cracks, corrosion, and evidence of shorting or other damage.
- (12) Inspect fuse holder for cracks, corrosion, and other damage. Check fuse for burned out condition. Check fuse for continuity if in doubt.
- (13) Inspect brush assembly for corrosion and excessive wear.

#### NOTE

The brushes are excessively worn if 3/16-inch or less extends beyond the bottom of the holder.

- (14) Check brush spring tension. A force of 4 to 6 ounces should move brush against spring.
- (15) Using an ohmmeter, test brushholder assembly as follows.
  - (a) Attach one test lead to brushholder and touch other lead to each terminal and each brush. There should be no indication of continuity between brushholder and any terminal or brush.
  - (b) Check for non-continuity between each terminal and its respective brush.
- (16) Replace brushholder assembly if inspection and test requirements are not met.

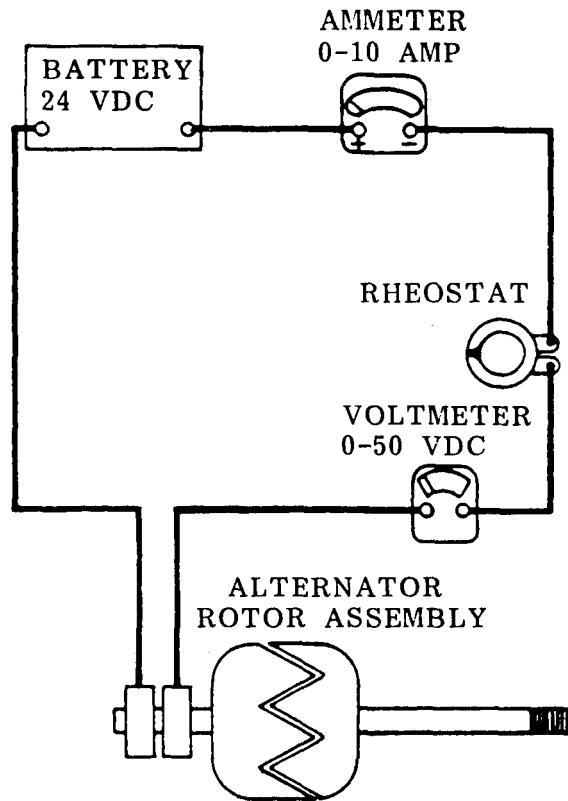


Figure 7-7. Rotor Assembly Current Draw Test Circuit.

- (17 ) Inspect pulley for excessive wear at pulley groove, cracks, corrosion, and other damage.
- (18) Inspect fan for cracks, corrosion, bent blades and other damage.
- (19) Inspect bearings for pitting, excessive wear, and other damage.
- (20) Inspect all threads for crossing, stripping, and peening.

Refer to figure 7-6 to assemble the alternator in reverse

d. Assembly.

e. Testing.

- (1) Manufacture test leads as follows:
  - (a) From No. 8 or 10 insulated wire, cut three lengths, one 10 inches long and two 5 inches long.
  - (b) Strip both ends of all three leads and tin with solder.
  - (c) Attach a 1/4-inch ring terminal to one end of the 10-inch lead.
  - (d) Attach a No. 10 ring terminal to one end of each 5-inch lead.
- (2) Install test leads as follows:
  - (a) Attach the test leads as shown in figure 7-8. Pass the free end of each lead through the ventilated band cover.
  - (b) Install regulator and cover assembly and secure with screws.
- (3) Install alternator in test circuit as shown in figure 7-9.

**NOTE**

**The test circuit is identical to the alternator installation circuit. If an operational set is available, the alternator may be installed on it for testing.**

- (a) With switch open, compare voltage readings at V1 and V2. The readings should be identical.

**NOTE**

While checking voltage at V2, check to see if the reading varies when the cable or the connector plug on the alternator cover assembly is disturbed. This could indicate inadequate test connections which must be corrected before proceeding with the tests.

- (b) If voltage at V2 is low or zero, the alternator positive and negative output circuits must be tested as indicated in steps (4) and (5) below.
- (4) Test alternator positive output circuit as follows:
- (a) Check voltage at V3 as shown in figures 7-8 and 7-9.
  - (b) If voltage is zero, check fuse.
  - (c) If voltage is greater than zero, but below voltage V1 figure 7-10 check for poor circuit conditions between battery positive terminal and alternator positive output terminal.
  - (d) Correct any discrepancies before proceeding with operational tests.
  - (e) If voltage indicated is equal to voltage V1, test alternator negative output circuit as directed in step (5) below.
- (5) Test alternator output circuit as follows:
- (a) Check voltage V4 as indicated in figures 7-10 and 7-12.
  - (b) If voltage is below voltage at V1 (fig. 7-10), check for inadequate circuit conditions between battery negative terminal and alternator negative output terminal.
  - (c) Correct any discrepancies before conducting operational tests.
- (6) Conduct excitation voltage test as follows:
- (a) With voltmeter connected as in figure 7-11, close switch.
  - (b) Voltmeter should indicate 3.5  $\pm 0.2$  Vdc.
  - (c) If voltmeter indicates zero volts, test voltage regulator as directed in step (7) below.
  - (d) If voltmeter indication is greater than 3.7 Vdc, test for open circuit of alternator field (rotor) as directed in step (8) below.

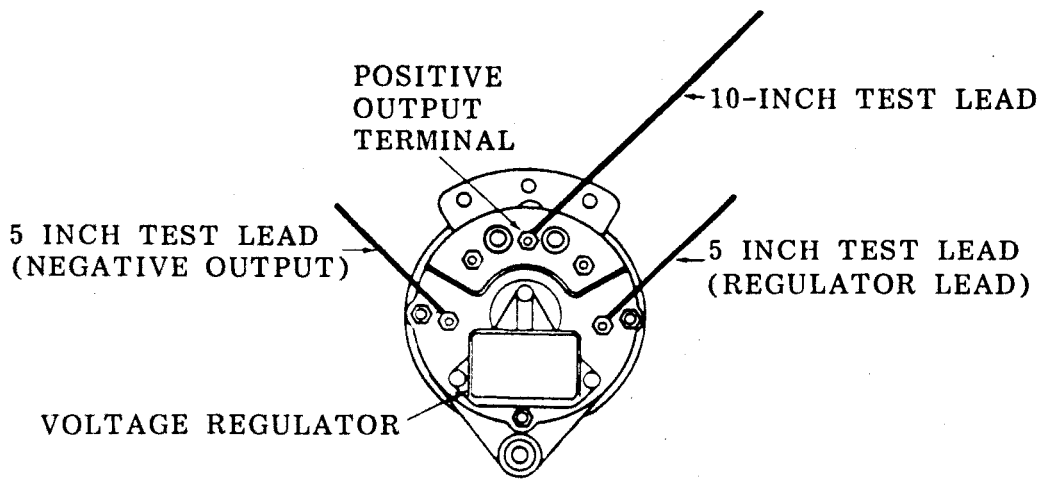


Figure 7-8. Alternator Test Leads Installation.

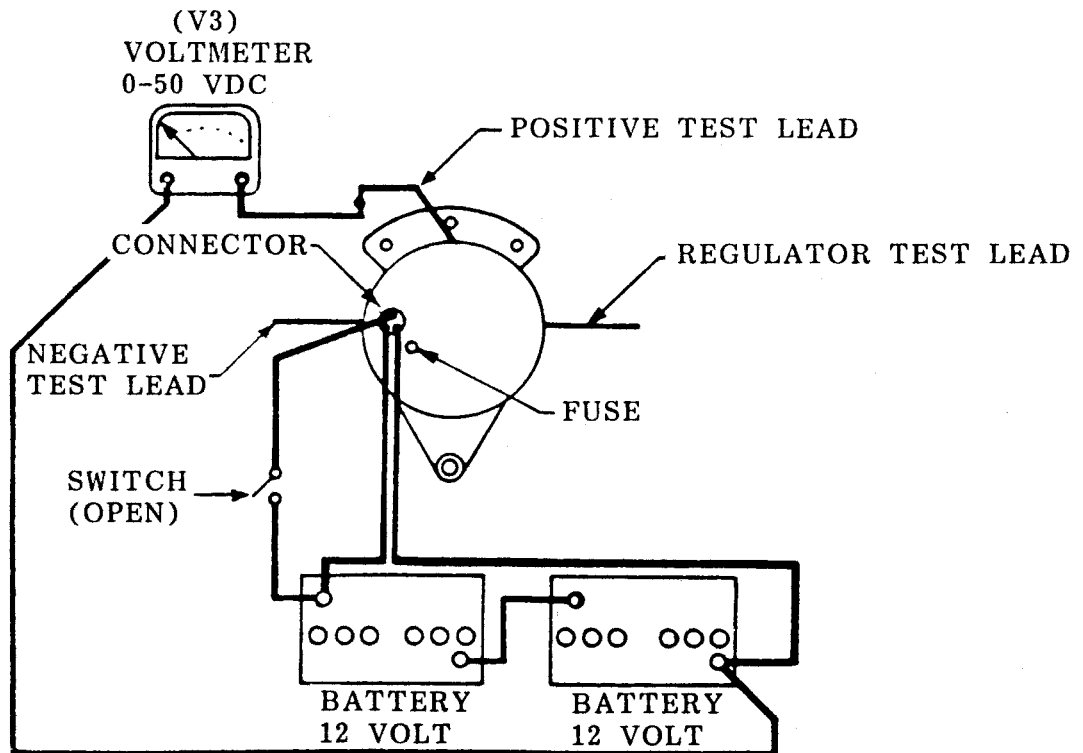


Figure 7-9. Alternator Positive Output Circuit Test.

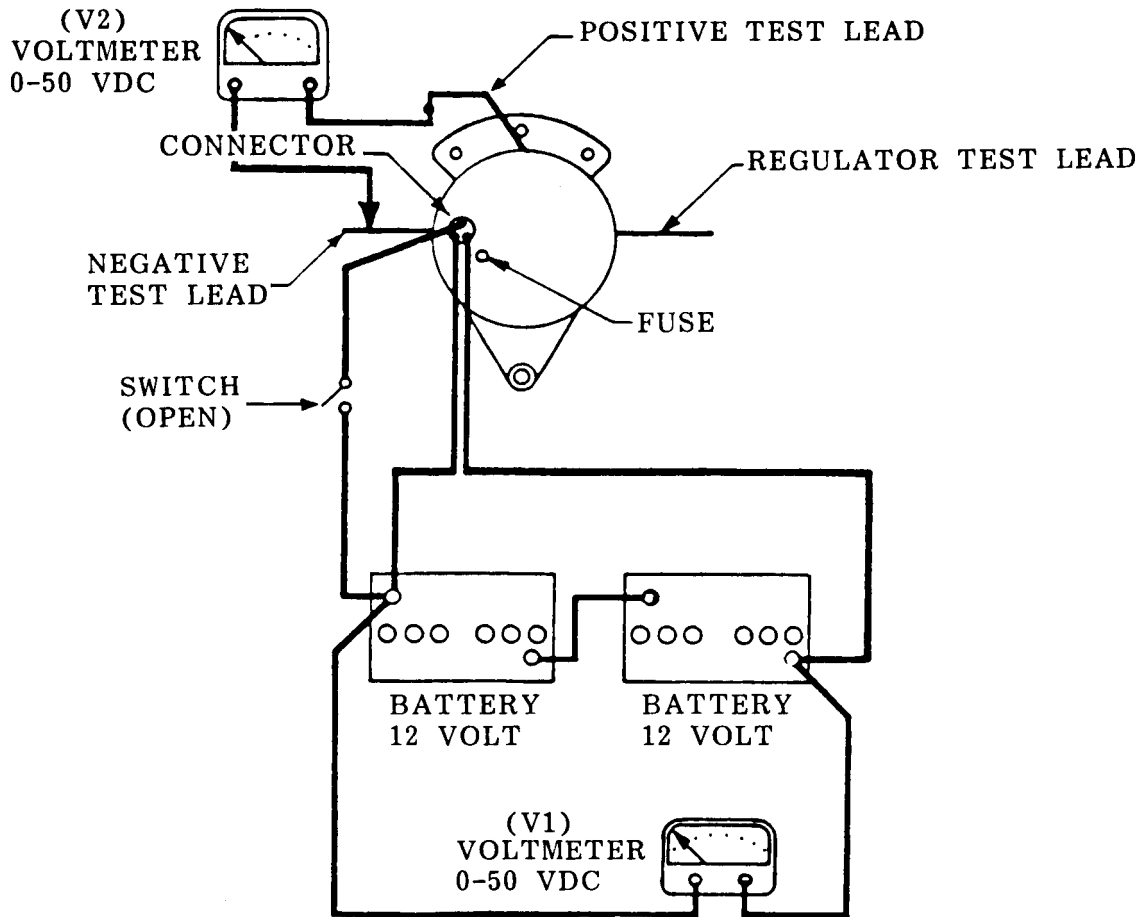


Figure 7-10. Total Circuit Voltage Test.

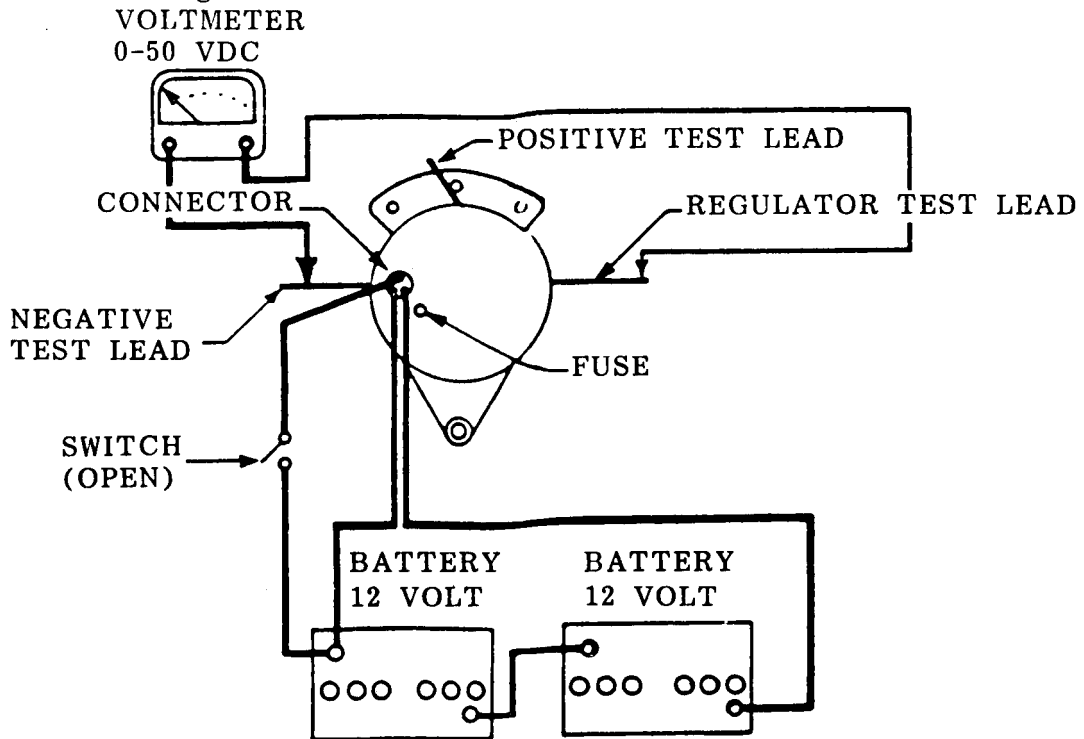


Figure 7-11. Excitation Voltage Tests.

- (e) If voltmeter indication is as specified, proceed with voltage regulator, alternator output, and voltage protector test as outlined in step (9) below,
- (7) Test for faulty alternator voltage regulator as follows:
- (a) Remove screws and cover assembly.
  - (b) Disconnect voltage regulator by disconnecting and tagging the red, green, and black leads.
  - (c) Disconnect and tag the blue and yellow output leads.
  - (d) Install a jumper wire from the GND terminal to brush terminal as shown in figure 7-13.
  - (e) Install alternator in test circuit as shown in figure 7-13.

**NOTE**

A means of rotating the alternator at 2,000 to 3,000 rpm must be provided. This test can be performed with the alternator installed on an operational set and operating the set at rated frequency.

- (f) With the alternator rotating at 2,500 rpm, the voltmeter should indicate 24 to 28 volts and ammeter should indicate 32 to 34 amperes.
  - (g) If the alternator tests satisfactorily, this indicates that the voltage regulator was faulty.
  - (h) If the alternator does not test satisfactorily, this indicates that the voltage regulator is good and the trouble is on the alternator.
  - (i) If the regulator is faulty, remove the jumper and install a new regulator and cover assembly using the tagged identification as a guide.
- (8) Conduct field current test as follows:

**CAUTION**

Rheostat must be set in maximum resistance position to protect the ammeter in the event the field circuit is short circuited.

- (a) Install the ammeter in test circuit as shown in figure 7-14.

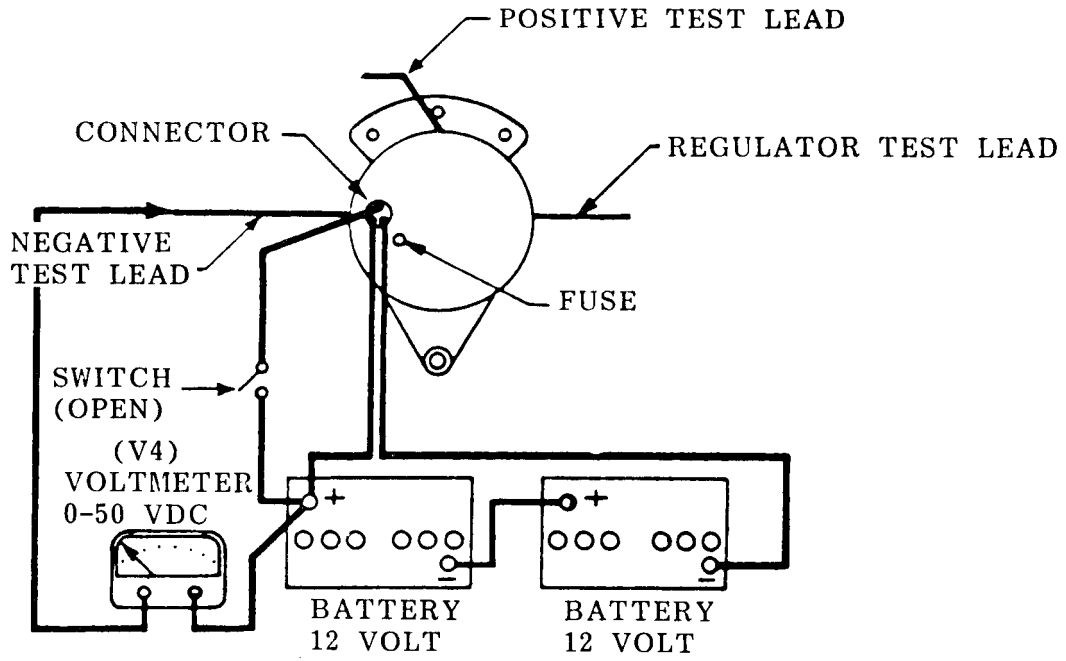


Figure 7-12. Alternator Negative Output Circuit Test.

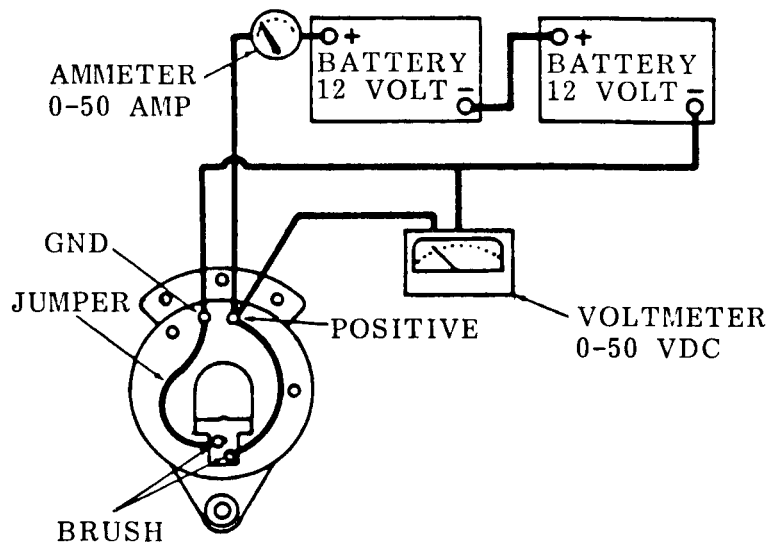


Figure 7-13. Faulty Voltage Regulator Circuit Test.



- (b) Slowly reduce field rheostat resistance while observing ammeter and voltmeter.
  - (c) When field rheostat reaches zero ohms, ammeter should indicate 3.0 to 3.5 amperes with voltmeter indicating 24 Vdc.
  - (d) If current is not as specified, check for poor connections and inadequate brush contact.
- (9) Conduct alternator output and voltage protector test as follows:
- (a) Install alternator in test circuit shown in figure 7-15.

#### NOTE

If alternator is not installed for this test, a means of rotating the alternator at 2,000 to 3,000 rpm must be provided.

- (b) Adjust the drive device to provide 2,500 rpm.
- (c) Note the voltmeter indication. Nominal voltage should be  $28 \pm \text{Vdc}$ .
- (d) If voltage is not specified, adjust the voltage regulator rheostat on the alternator rear cover.
- (e) Close switch (S2) and put carbon pile load on batteries.
- (f) Check ammeter and voltmeter indications. Nominal current output should be 20-25 amperes with charging voltage exceeding 25 Vdc.

#### CAUTION

Open switch (S2) immediately after current test to avoid discharging the batteries.

- (g) If nominal voltage cannot be obtained, disassemble alternator and correct difficulty.
  - (h) Remove alternator from test circuit, remove rear cover and disconnect test leads.
- f. Installation. Refer to figure 7-2 and install the alternator.

### 7-5. COOLANT TEMPERATURE TRANSMITTER.

- a. Removal.
  - (1) Drain coolant from the radiator.

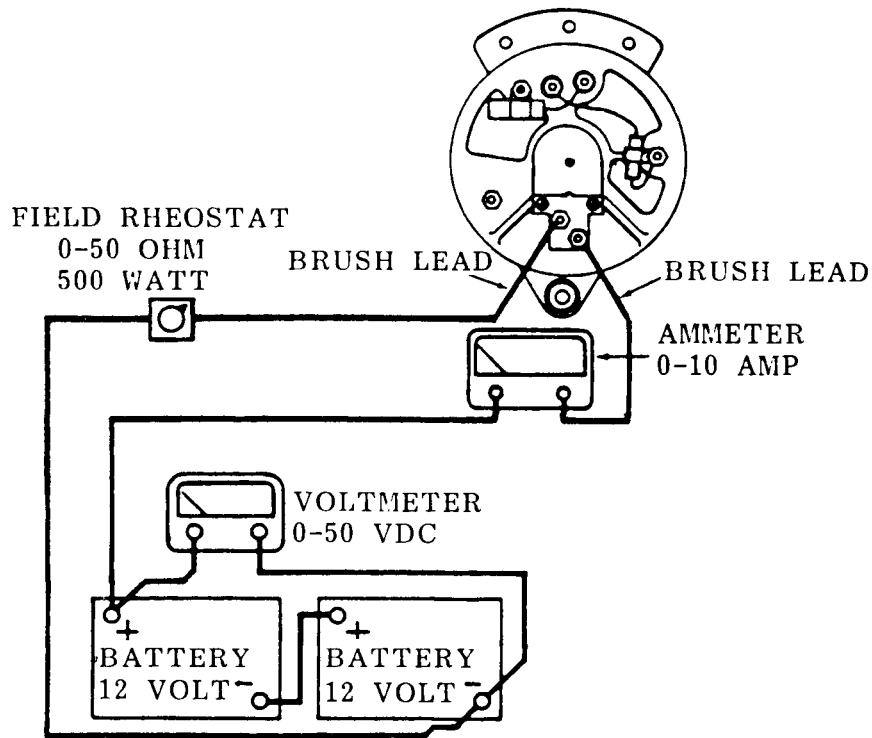


Figure 7-14. Field Current Test.

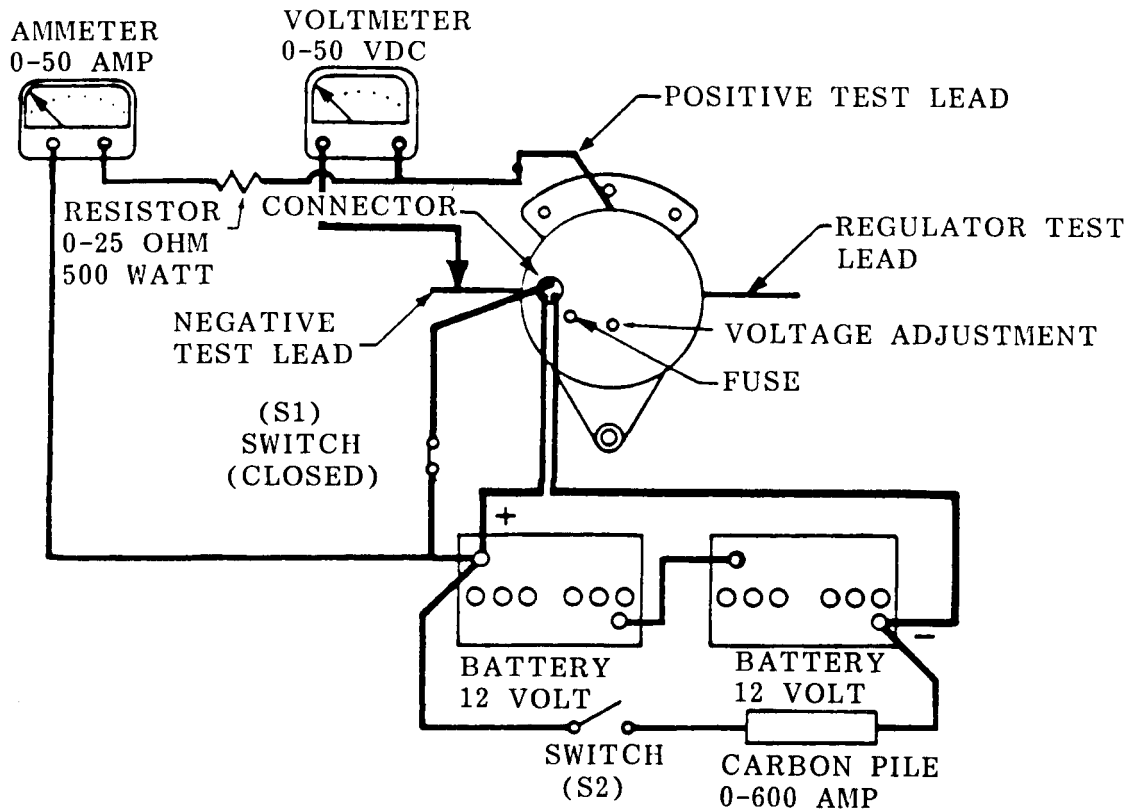


Figure 7-15. Output and Voltage Protection Test.

- (2) Disconnect wiring connector from temperature transmitter,
- (3) Refer to figure 7-16 and remove the temperature transmitter.

b. Cleaning and Inspection.

- (1) Clean with compressed air and a soft bristle brush or with a clean lint-free cloth moistened with an approved solvent.
- (2) Inspect for cracked casing, corrosion, and damaged threads and connections.

c. Installation.

- (1) Refer to figure 7-16 and install the temperature sensors.
- (2) Connect electrical wiring connector.
- (3) Service the radiator as required.

## 7-6. OIL PRESSURE SENDING UNITS.

a. Removal.

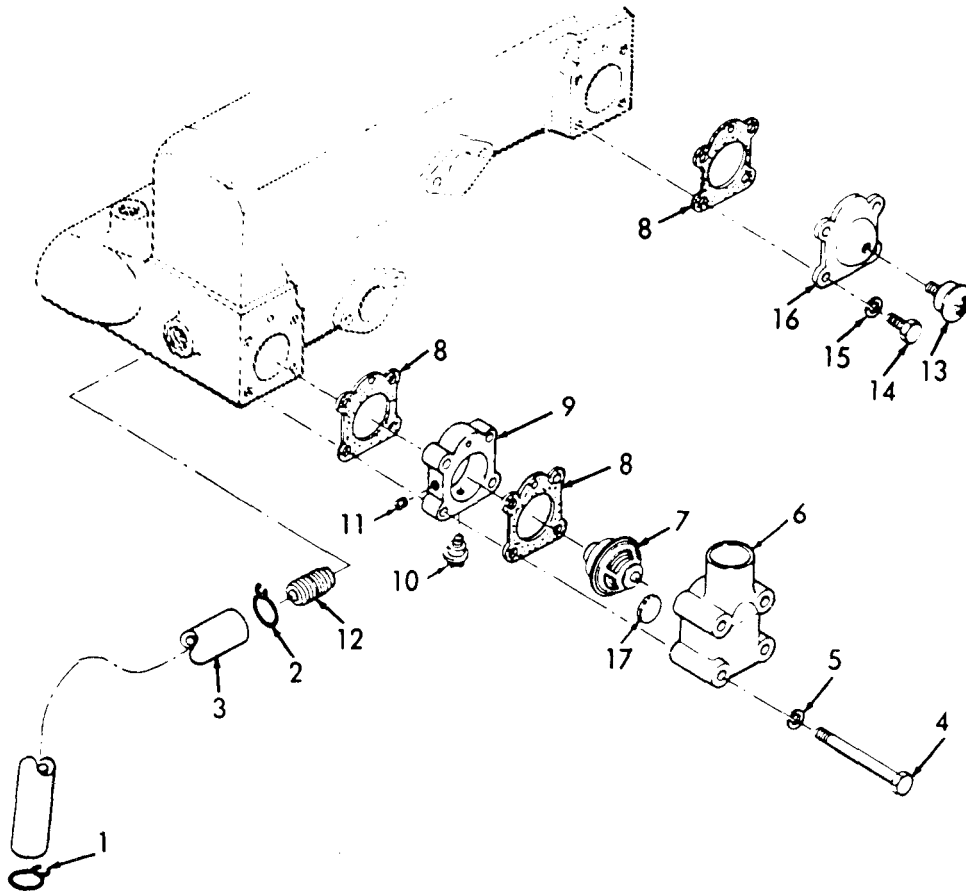
- (1) Tag and disconnect electrical leads from the sending unit.
- (2) Refer to figure 7-17 and remove the oil sending units.

b. Cleaning and Inspection.

- (1) Clean the sending units with compressed air and a soft bristle brush or wipe with a clean, lint-free cloth lightly with an approved solvent.
- (2) Inspect sending units for cracked casing, stripped or damaged threads, corrosion, or other visible damage.

c. Installation.

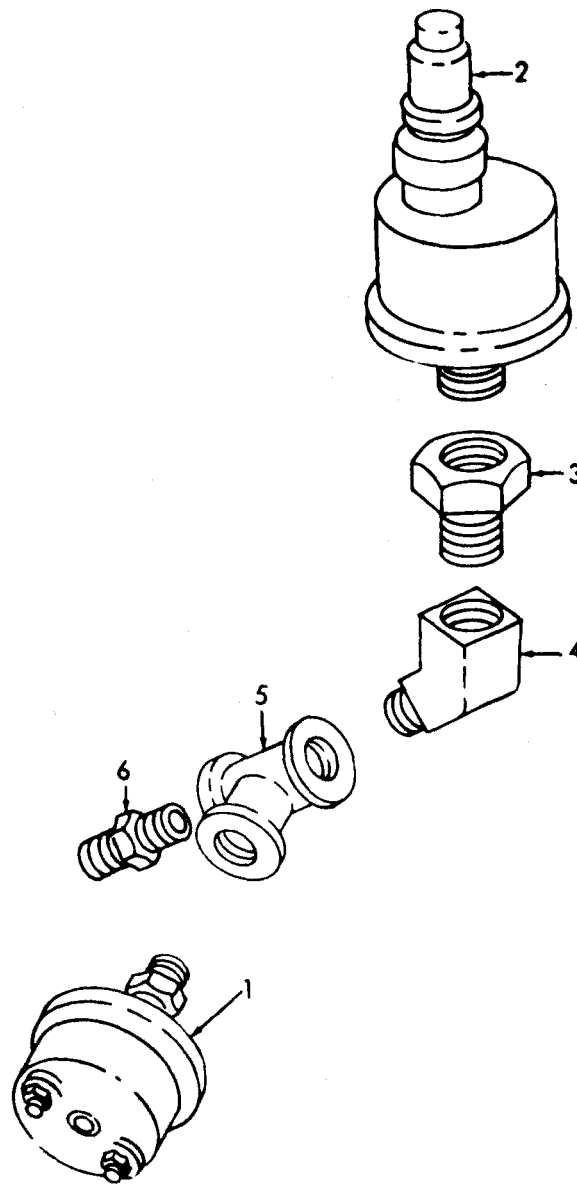
- (1) Install the oil sending units (refer to figure 7-17).
- (2) Connect the electrical leads to the sending units per the tagged identification.



LEGEND FOR FIGURE 7-16:

ITEM	NSN	P/N	FSCM	QTY
1. Clamp, Hose	4730-00-908-3198	MS35642-12	96906	1
2. Clamp, Hose	4730-00-908-3193	2083838	28265	1
3. Hose, Bypass	4720-00-977-0316	288752A	28265	1
4. Screw, Cap	5305-00-934-0279	202864A	28265	4
5. Washer, Lock	5310-00-637-9541	201410A	28265	4
6. Housing		288750C	28265	1
7. Thermostat	6620-00-841-1892	206816C	28265	1
8. Gasket	5330-00-971-5607	266701A	28265	3
9. Spacer		2887288	28265	1
10. Transmitter	6685-00-814-5217	2506018	28265	1
11. Plug, Pipe	4730-00-834-6187	MS51884-7H	96906	2
12. Nipple		3204A	28265	1
13. Switch	5930-00-135-3124	25050B	28265	1
14. Screw, Cap	5305-00-616-5649	315A	28265	4
15. Washer, Lock	5310-00-637-9541	MS35338-45	96906	4
16. Cover		40-3070101B	28265	1
17. Plug, Cap		203924A	28265	1

Figure 7-16. Coolant Thermostat and Sensors, Removal and Installation.



LEGEND FOR FIGURE 7-18:

ITEM	NSN	P/N	FSCM	QTY
1. Switch, Pressure	5930-00-450-1136	2505418	28265	1
2. Transmitter, Oil		250974C	28265	1
3. Reducer, Pipe		5313A	28265	1
4. Elbow		6287A	28265	1
5. Tee		3131A	28265	1
6. Adapter		13238A	28265	1

Figure 7-17. Oil Sending Units, Removal and Installation.



## CHAPTER 8

## ENGINE FUEL SYSTEM

8-1. General. Fuel is supplied from the main fuel tank. Fuel is pumped through the filter assembly by a fuel transfer pump. The fuel transfer pump facilitates the flow of fuel from the tank to the fuel injection pump. The mechanical-type pump is a conventional cam-driven diaphragm pump that mounts on the engine block. The fuel injection pump distributes and delivers an accurately metered amount of fuel to each injector nozzle in a properly timed relationship. A flyball-type governor provides automatic control of the fuel charge in accordance with the engine load at any given speed range within the minimum and maximum speed settings. The fuel injector nozzles spray a metered amount of fuel into each combustion chamber. Unused fuel is returned to the tank through the fuel return line.

8-2. Fuel Tank, Lines, and Fittings.

## WARNING

The diesel fuel used in the engine for the Dynamotor-Welder is combustible. Use caution when draining/filling fuel tank and working on the fuel system. Extinguish all smoking materials and do not allow sparks or open flame near the fuel tank and fuel system.

a. Removal. Remove the fuel tank, lines, and fittings as illustrated in figure 8-1 only after draining the fuel tank.

## NOTE

The fording valve on the inside center of the fuel tank cap must remain open at all times. If, for any reason, the valve becomes defective and will not remain open, replace the fuel tank cap.

b. Cleaning and Inspection.

(1) Clean the fuel tank with cleaning solvent and blow out excess solvent with compressed air.

(2) Inspect all gaskets for wear, tears, and deterioration.

(3) Clean all hardware in solvent and inspect for stripped threads.

(4) Inspect fuel tank for leaks, cracks, holes, defective welds, and other damage.

(5) Replace all defective or missing parts.

c. Installation. Install the fuel tank, lines, and fittings as shown by figure 8-1.

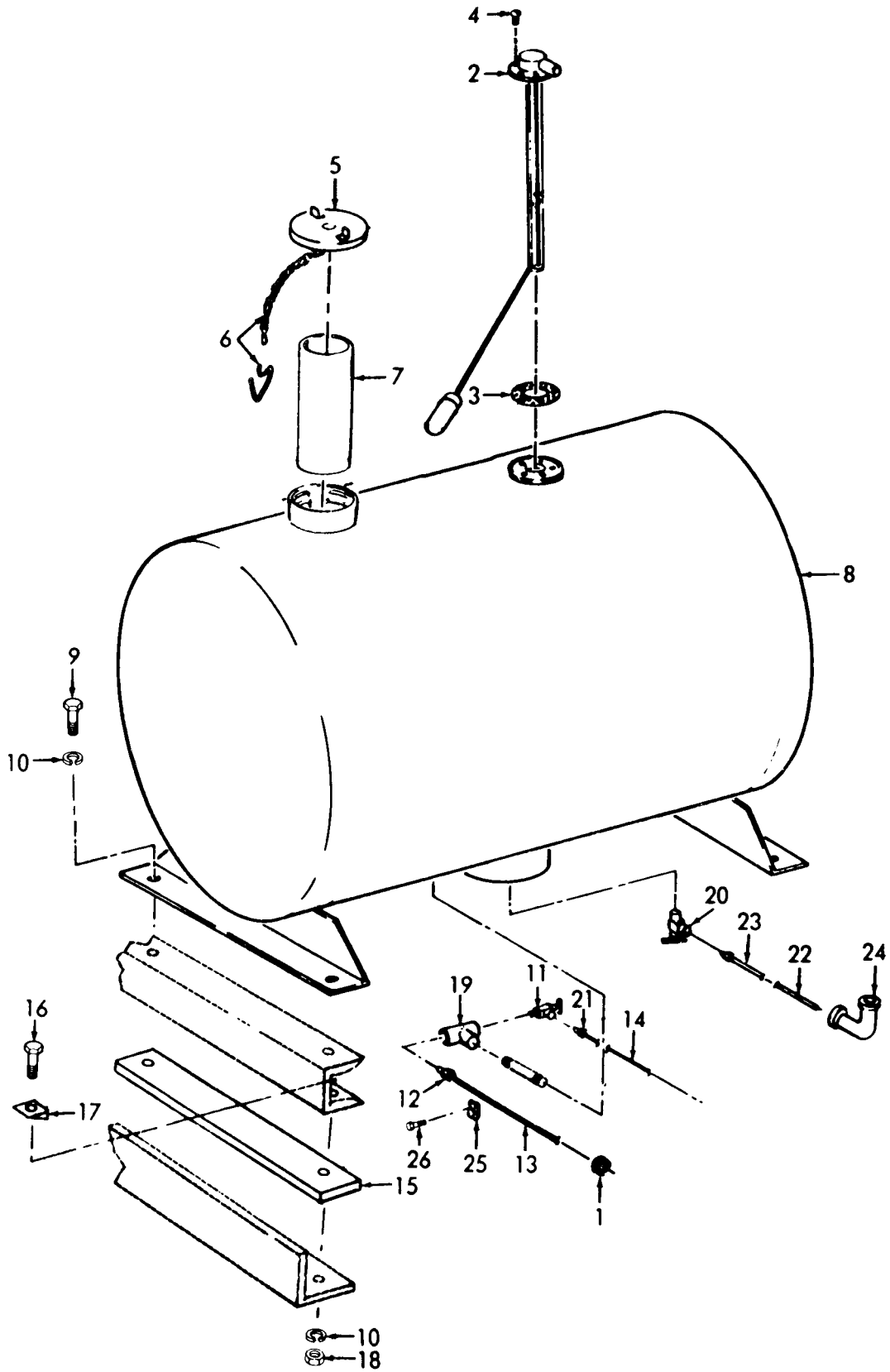


Figure 8-1. Fuel Tank, Lines, and Fittings, Removal and Installation.



## LEGEND FOR FIGURE 8-1:

ITEM	NSN	P/N	FSCM	QTY
1. Grommet	5325	MS3535490-80	96906	2
2. Gage		13217E0570	59678	1
3. Gasket	5330-01-114-9338	13217E0600	59678	1
4. Screw, Machine	5305-00-984-6191	MS35206-243	96906	5
5. Cap, Filler	2910-00-141-9758	MS35645-1	96906	1
6. Pin	5315-00-514-2660	MS29523-1	96906	1
7. Filler, Neck		MS35644-5	96906	1
8. Tank Assy.		13217E0517	97403	1
9. Screw, Cap	5305-00-071-2065	MS90725-108	96906	4
10. Washer, Lock	5310-00-584-5272	MS35338-48	96906	6
11. Valve, Needle		13217E1065-3	59678	1
12. Nut, Coupling	4730-01-045-7977	MS39166-4	96906	1
13. Tube		SW1743P1	98255	1
14. Tube	4710-00-277-5526	SW1561P	98255	1
15. Sill, Wood, Frame		13217E0591	59678	2
16. Screw, Cap	5305-00-716-8128	MS90725-117	96906	2
17. Washer, Bevel	4310-01-067-8188	13217E0590	59678	2
18. Nut, Plain	5310-00-768-0318	MS51967-14	96906	2
19. Tee, Pipe		13217E0119-32	59678	1
20. Valve, Needle		13217E1065-4	59678	1
21. Nut, Coupling	4730-00-902-9990	MS39168-5	96906	1
22. Tube		SW1743P3	98255	1
23. Tube		SW1763P	98255	1
24. Elbow	4730-00-837-0685	MS35917-3	96906	1
25. Clamp Loop	5340-00-150-1658	MS21333-68	96906	2
26. Screw	5305-00-855-0957	MS34629-46	96906	2

8-3. Fuel Transfer Pump.

WARNING

The diesel fuel used in the engine for the Dynamotor-Welder is combustible. Use caution when draining/filling fuel tank and working on the fuel system. Extinguish all smoking materials and do not allow sparks or open flame near the fuel tank and fuel system.

a. Removal.

(1) Disconnect fuel lines from the fuel transfer pump.

(2) Refer to figure 8-2 and remove the fuel transfer pump.

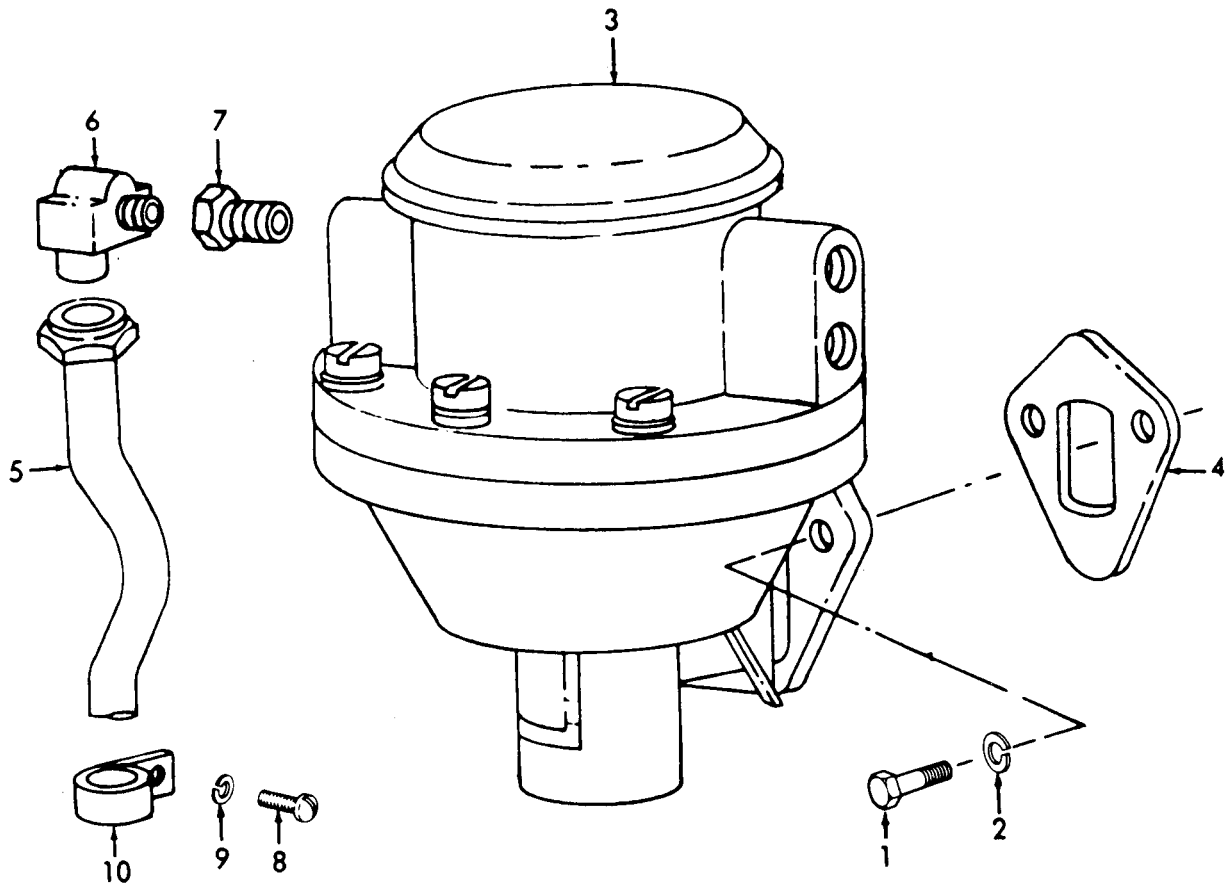


Figure 8-2. Fuel Transfer Pump, Removal and Installation.

b. Cleaning and Inspection.

(1) Clean fuel transfer pump with a clean lint-free cloth moistened with cleaning solvent.

(2) Inspect fuel transfer pump for cracks, corrosion, or other damage. Replace a defective fuel pump.

c. Installation.

(1) Refer to figure 8-2 and install the fuel transfer pump.

(2) Connect fuel lines to the fuel transfer pump.

## 8-4. Primary Fuel Filter.

## WARNING

The diesel fuel used in the engine for the Dynamotor-Welder is combustible. Use caution when draining/filling fuel tank and working on the fuel system. Extinguish all smoking materials and do not allow sparks or open flame near the fuel tank and fuel system.

a. Service (Refer to figure 8-3).

(1) Remove drain plug in filter housing and allow fuel to drain into a suitable container.

(2) Remove center screw to remove filter housing and gasket.

(3) Remove element from housing and discard.

(4) Install new element into housing.

(5) Install a new gasket, housing and center screw. Tighten center screw securely.

(6) Install drain plug into filter housing and tighten securely.

b. Removal.

(1) Remove drain plug in filter housing and allow fuel to drain into a suitable container.

(2) Refer to figure 8-3 and remove filter assembly.

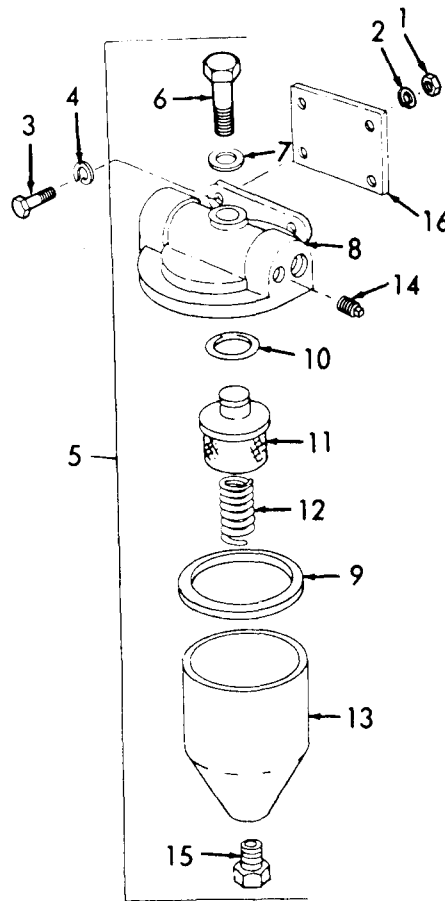
c. Cleaning and Inspection.

(1) Clean fuel filter assembly in an approved solvent and dry thoroughly.

(2) Inspect filter head and housing for cracks, corrosion, and other damage.

(3) Replace any defective parts.

d. Installation. Refer to figure 8-3 and install the fuel filter.



LEGEND FOR FIGURE 8-3:

ITEM	NSN	P/N	FSCM	QTY
1. Nut		1500-02222	28265	2
2. Washer		2012-04022	28265	4
3. Screw	5305-01-077-9914	1000-12152	28265	2
4. Washer		2012-04022	28265	2
5. Filter, Assy.		5573209	70040	1
6. Screw	5305-00-529-1728	853634	70040	1
7. Washer		6439448	70040	1
8. Head, Filter		1504212	70040	1
9. Gasket		853558	70040	1
10. Gasket		853573	70040	1
11. Element, Filter		853874	70040	1
12. Spring		1504249	70040	1
13. Body		1504117	70040	1
14. Plug, Pipe	4730-00-221-2137	MS20913-25	96906	2
15. Plug, Pipe		1595875	70040	1
16. Bracket		40-0020513C	28265	1
17. Filter, Gasket (Consist of #9, 10, & 11)	2910-00-375-4409	1595654	70040	1

Figure 8-3. Primary Fuel Filter, Removal and Installation.

## 8-5. Secondary Fuel Filter.

## WARNING

The diesel fuel used in the engine for the Dynamotor-Welder is combustible. Use caution when draining/filling fuel tank and working on the fuel system. Extinguish all smoking materials and do not allow sparks or open flame near the fuel tank and fuel system.

a. Removal (Refer to figure 8-4).

(1) Remove drain plug from filter housing and allow fuel to drain into a suitable container.

(2) Disconnect fuel hose assembly.

(3) Remove the secondary fuel filter.

b. Cleaning and Inspection.

(1) Clean fuel filter assembly parts in an approved solvent and dry thoroughly.

(2) Inspect filter head and housing for cracks, corrosion, and other damage.

(3) Replace any defective parts.

c. Installation. Install the fuel filter per figure 8-4.

## 8-6. Fuel Injection Pump.

## WARNING

The diesel fuel used in the engine for the Dynamotor-Welder is combustible. Use caution when draining/filling fuel tank and working on the fuel system. Extinguish all smoking materials and do not allow sparks or open flame near the fuel tank and fuel system.

a. Removal (Refer to figure 8-5).

## CAUTION

Thoroughly clean the fuel injection pump prior to removal. Cap or plug all fittings and lines to prevent dirt from entering the pump and fuel system.

(1) Disconnect injector return lines (1 and 2) and remove tee (3).

(2) Disconnect the throttle and stop controls.

## NOTE

When the injection pump is removed from the engine for repair, the throttle liner should be tied in the wide open position while it is in transit or storage. This prevents the governor weights from dislodging inside the pump housing.

(3) Disconnect the inlet fuel line (4) and remove elbow (5).

(4) Disconnect the fuel injector lines and cover.

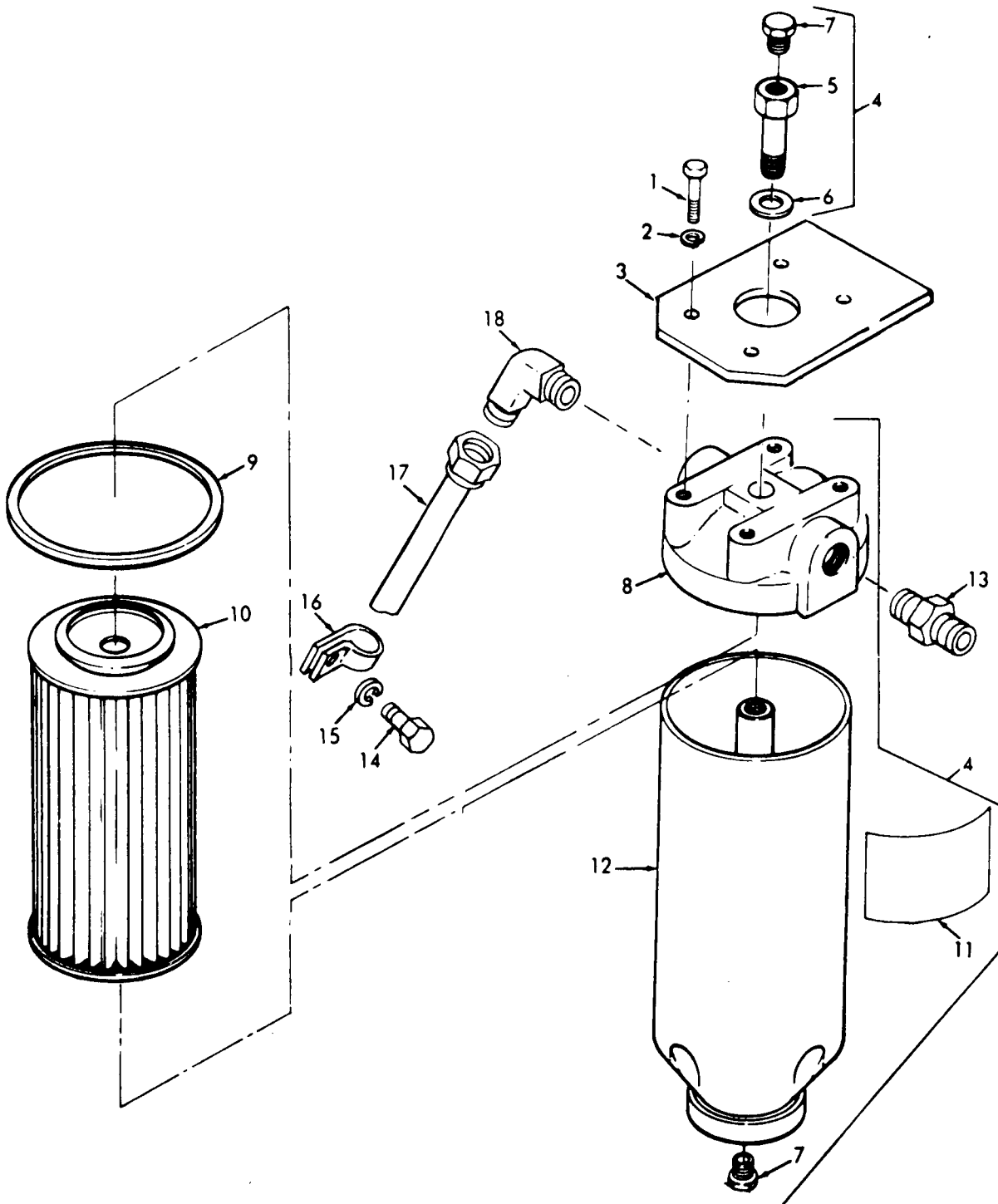


Figure 8-4. Secondary Fuel Filter, Removal and Installation.

## LEGEND FOR FIGURE 8-4:

ITEM	NSN	P/N	FSCM	QTY
1. Screw	5305-01-077-9913	1000-12149	28265	1
2. Washer, Lock		2012-04022	28265	2
3. Bracket		40-0020514C	28265	1
4. Filler Assy.				
5. Bolt	4730-00-784-1681	101486	73370	1
6. Gasket		101487	87405	1
7. Plug, Pipe		151728	87405	2
8. Head		101488	87405	1
9. Gasket		101489	87405	1
10. Element, Filter		121708	87405	1
11. Plate, ID		132153	87405	1
12. Body Assy.		231230	87405	1
13. Nipple	4730-00-143-4070	40-0005540	28265	1
14. Bolt, Machine	5306-00-207-8373	1000-12159	28265	4
15. Washer	5310-00-080-6004	MS27183-14	96906	4
16. Clamp	5340-00-630-4813	40-00022727A	28265	1
17. Hose Assy.		40-0016653A	28265	1
18. Elbow	4730-00-496-7330	204802A	28265	1
19. Kit, Filter (Contains #6, 9, & 10)		127630AS	28265	1

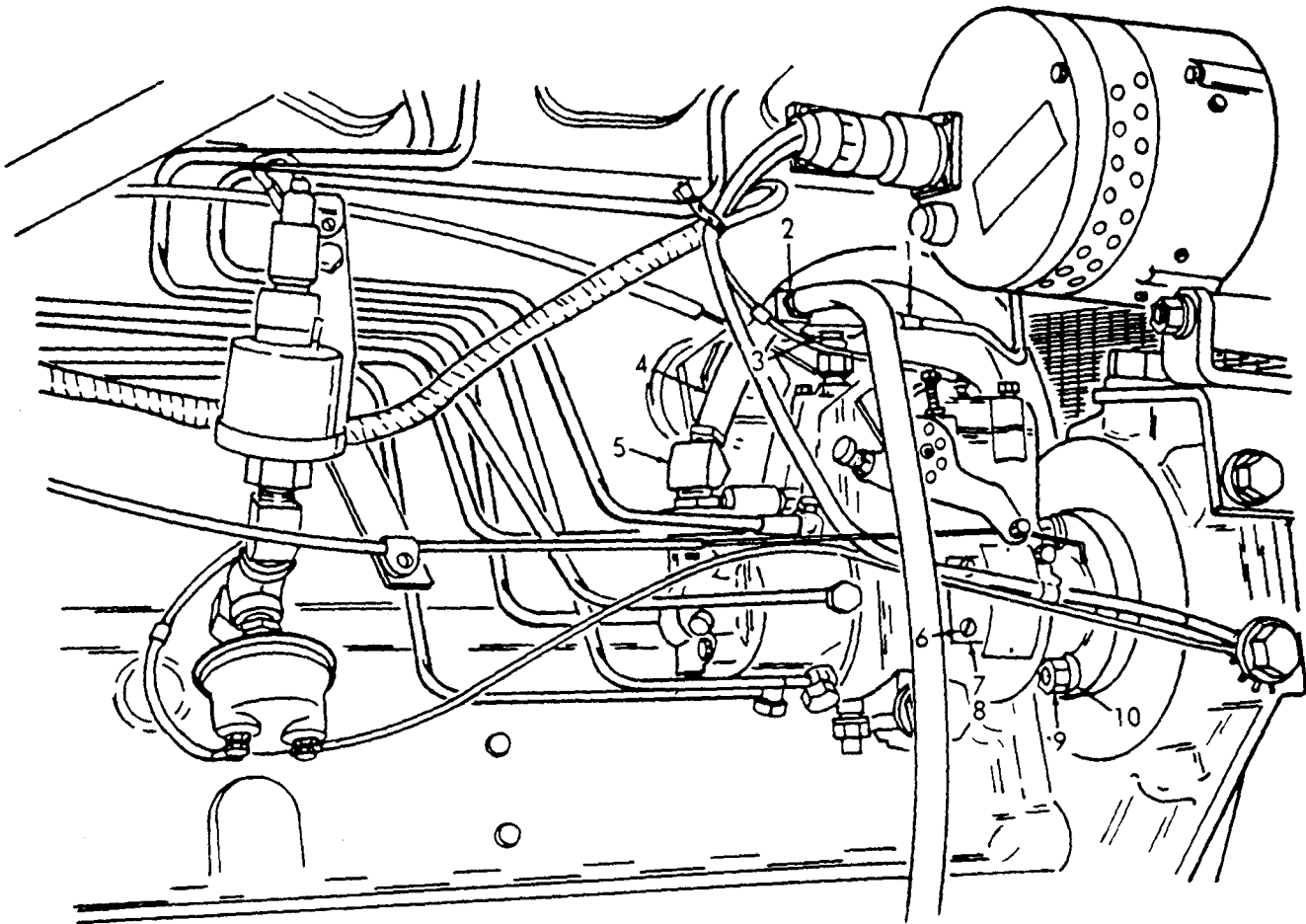


Figure 8-5. Fuel Injection Pump, Removal and Installation.



- (5) Remove screws (6), timing line cover (7), and gasket (8).
- (6) Turn the engine over in the direction of rotation until the timing line on the governor retainer hub aligns with the timing line on the pump cam.
- (7) Remove bolts and lockwashers securing thrust plate to gear housing cover. Remove thrust plate and discard gasket.
- (8) Remove thrust plug and spring from fuel pump drive shaft.
- (9) Remove nut and washer that secure fuel pump drive gear to pump drive shaft.
- (10) Remove nuts (9) and lockwashers (10).
- (11) Disengage pump from gear housing approximately 1/4-inch. Using a soft hammer, tap injection pump drive shaft to remove pump from drive gear.
- (12) Carefully slide fuel injection pump from the timing gear housing.

- b. Disassembly (Refer to figures 8-6 through 8-12).

#### NOTE

Place all parts in a pan containing clean oil. Discard all O-rings and gaskets.

#### CAUTION

Never clamp the pump in a vise without using the fixture.

- (1) Mount the pump in holding fixture and secure.
- (2) Remove three screws (6, figure 8-6) and remove cover containing solenoid.
- (3) Rotate shut-off lever (8, figure 8-7 ) to full shut-off position; place a screwdriver between housing and linkage hook (29, figure 8-7), and pry off shut-off cam (1, figure 8-7). Discard shut-off cam.
- (4) Partially withdraw throttle shaft assembly (18, figure 8-7 ) and lift out throttle shaft lever ( 24, figure 8-7 ), spacers and damper barrel assembly (8, figure 8-7 ).
- (5) Remove throttle shaft assembly and shut-off shaft assembly (10, figure 8-7).

- (6) Loosen end plate sleeve.
- (7) Remove screws (11, figure 8-8), lockwashers (12, figure 8-8), flat washers (13, figure 8-8), and transfer pump and plate (14, figure 8-8).
- (8) Remove thrust plate (15, figure 8-8).
- (9) Remove the pressure regulating sleeve (2, figure 8-8) from end plate (14, figure 8-8). Remove adjusting plug (1, figure 8-8). Slide off filter element (4, figure 8-8). Shake out the regulating spring (7, figure 8-8) and piston (8, figure 8-8). Reverse the assembly and remove the regulating piston seal (9, figure 8-8).
- (10) To disassemble the transfer pump, lift out transfer pump seal (17, figure 8-8, liner (20, figure 8-8), blades (18, figure 8-8), and springs (19, figure 8-8).
- (11) Remove the speed droop adjusting cap assembly (11, figure 8-9) by pulling it from control rod guide (13, figure 8-9).
- (12) Remove and discard control spring pin (4, figure 8-9).
- (13) Discard seals (12 and 15, figure 8-9), control rod guide (13, figure 8-9) and washer (14, figure 8-9).

**CAUTION**

Use care not to bend control rod.

- (14) Disengage governor spring (6, figure 8-9) from the governor arm (7, figure 8-9), then remove the governor spring and control rod assembly (5, figure 8-9).
- (15) Remove the metering valve (18, figure 8-9) and arm assembly (16, figure 8-9) from the hydraulic head.
- (16) Remove head locking screws (1 and 8, figure 8-12) from the pump housing (14, figure 8-9).
- (17) Invert pump and holding fixture as a unit and remove head locating screw (15, figure 8-10), advance screw hole plug (12, figure 8-10). Remove advance spring and power piston plugs (1 and 8, figure 8-10). Using the cam advance screw removal bushing, part number 15500, and the Bristol socket cam screw advance screw wrench, part number 15499, remove the cam advance screw (14, figure 8-10).

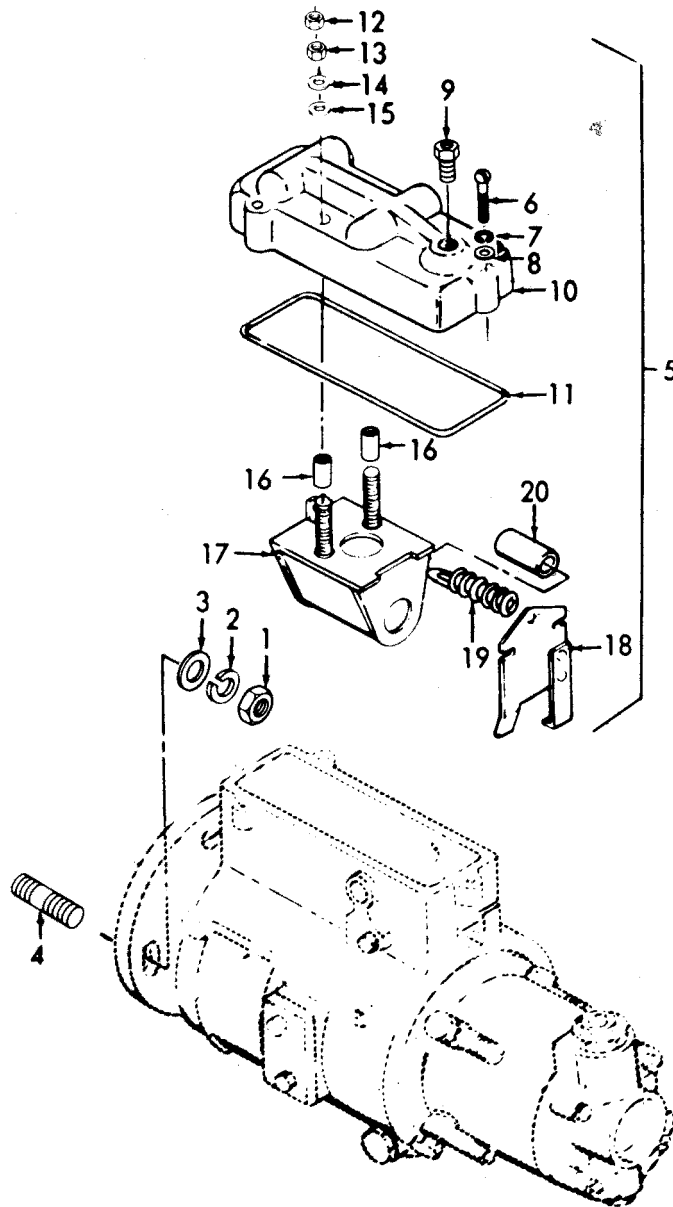


Figure 8-6. Fuel Injection Pump Governor.

LEGEND FOR FIGURE 8-6:

ITEM	NSN	P/N	FSCM	QTY
1. Nut, Plain	5310-00-732-0559	MS51968-8	96906	2
2. Washer, Lock	5310-00-637-9541	MS35338-46	96906	2
3. Washer, Flat	5310-00-209-3671	2W1-24-24-92	43999	2
4. Stud, Plain		6957A	28265	2
5. Pump, Fuel Injec.		D8GFC633-1HB	84760	1
6. Screw, Machine	5305-00-846-0129	MS35265-68	96906	3
7. Washer, Lock	5310-00-796-8638	11582	84760	3
8. Washer, Flat	5310-00-194-0607	13521	84760	3
9. Connector Assy.		15830	84760	1
10. Cover		12106	84760	1
11. Gasket	5310-00-640-9299	12054	84760	1
12. Nut Lock	5310-00-582-5765	8527012	18876	2
13. Nut, Plain	5310-00-934-9757	MS35649-282	96906	2
14. Washer, Flat	5310-00-190-0752	18501	84760	2
15. Washer, Terminal	5310-00-830-7825	12500	84760	2
16. Tube, Terminal		12513	84760	2
17. Frame Assy.		16355	84760	2
18. Arm Assy.		16278	84760	1
19. Spring		14480	84760	1
20. Sleeve		16396	84760	1

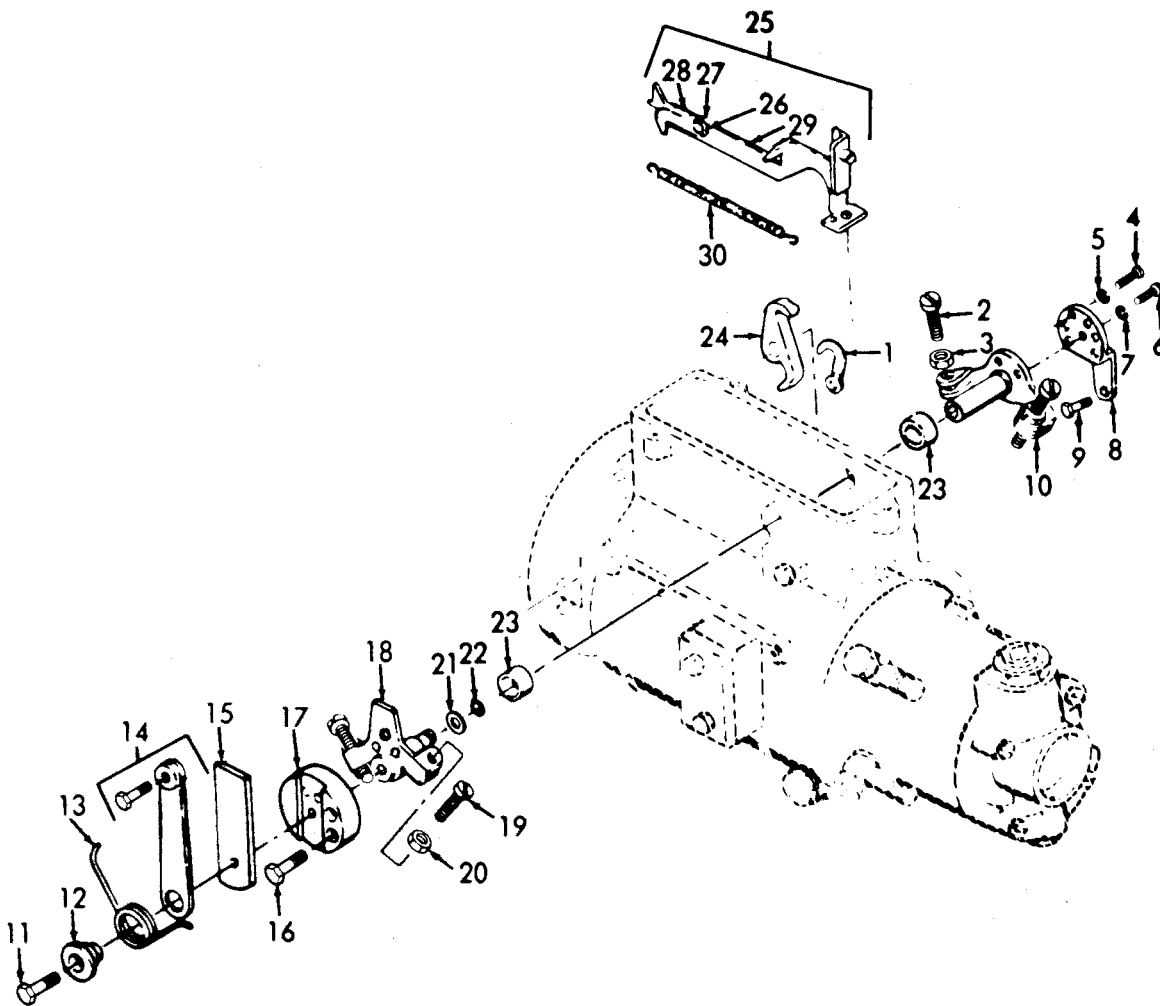
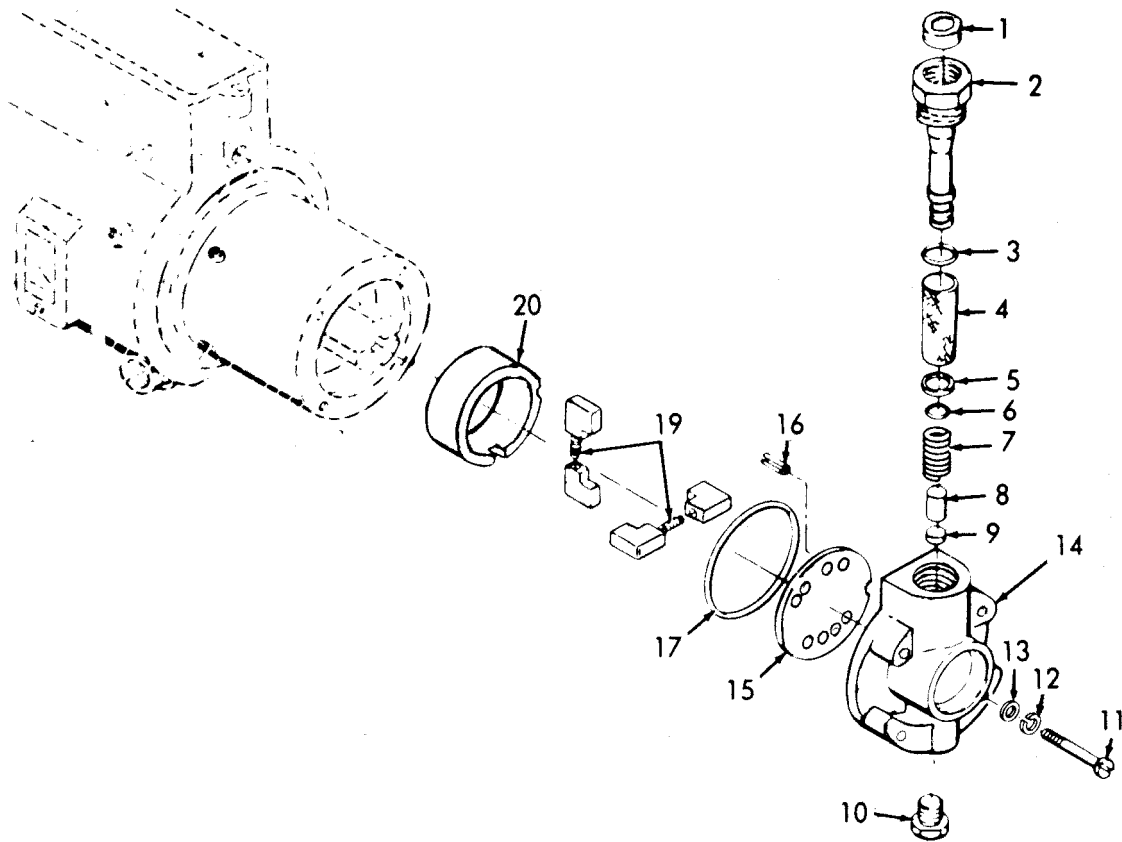


Figure 8-7. Fuel Injection Pump Linkage and Control.

LEGEND FOR FIGURE 8-7:

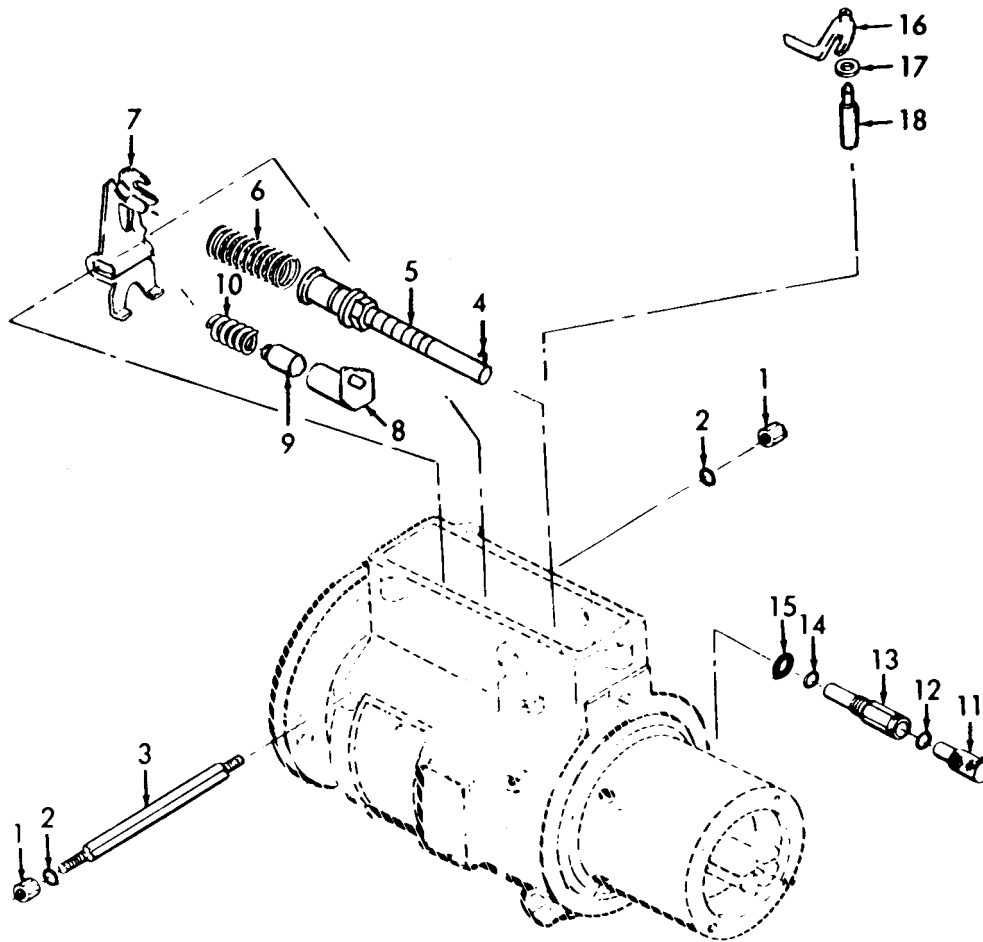
ITEM	NSN	P/N	FSCM	QTY
1. Cam, Shut-off		12249	84760	1
2. Screw, Machine	5305-00-891-8979	12972	84760	2
3. Nut, Plain	5310-00-934-9751	MS35650-302	96906	2
4. Screw, Machine	5305-00-978-9368	MS16997-30	96906	1
5. Washer	5310-00-559-0070	MS35338-38	96906	1
6. Screw, Machine	5305-00-007-1321	12998	84760	1
7. Washer, Flat	5310-00-790-8683	11582	84760	1
8. Arm Assy.		12295	84760	1
9. Screw, Machine	5305-00-788-3735	12957	84760	1
10. Shaft, Assy.		15119	84760	1
11. Screw, Cap	5305-00-125-6180	16137	84760	1
12. Retainer		13010	84760	1
13. Spring		13003	84760	1
14. Lever Assy.		15026	84760	1
15. Arm		16136	84760	1
16. Screw, Cap	5305-00-978-9368	MS16997-30	96906	1
17. Spacer		16135	84760	1
18. Shaft Assy.		15024	84760	1
19. Screw, Machine	5305-00-891-8979	12972	84760	1
20. Nut, Plain	5310-00-934-9751	MS35650	96906	2
21. Washer, Flat	5310-00-877-4956	14408	84760	2
22. Packing, Preforme	5330-00-641-8282	12040	84760	2
23. Spacer		16587	84760	2
24. Lever		12221	84760	2
25. Hook Assy.		11901	84760	1
26. Screw, Machine		12360	84760	1
27. Washer, Lock		12362	84760	1
28. Link Assy.		12358	84760	1
29. Hook, Governor		11900	84760	1
30. Spring		11919	84760	1



LEGEND FOR FIGURE 8-8:

ITEM	NSN	P/N	FSCM	QTY
1. Plug Assy .		15228	84760	1
2. Sleeve		17058	84760	1
3. Seal	5330-00-171-5641	12406	84760	1
4. Element, Filter	2910-00-898-4926	15225	84760	1
5. Washer	2910-00-898-4927	15627	84760	1
6. Ring	5330-00-641-8283	11507	84760	1
7. Spring		15913	84760	1
8. Piston		11508	84760	1
9. Seal	2910-00-901-0749	17056	84760	1
10. Plug, Pipe		15821	84760	1
11. Screw, Machine	5305-00-055-6736	17506	84760	4
12. Washer, Lock	5310-00-796-8683	11582	84760	4
13. Packing, Preformed	5310-00-853-2376	13521	84760	4
14. Plate, End		15877	84760	1
15. Plate, Thrust		15875	84760	1
16. Pin		11525	84760	1
17. Seal	5330-00-853-2376	11329	84760	1
18. Blade		18107	84760	4
19. Spring		15699	84760	2
20. Liner		16753	84760	1

Figure 8-8. Fuel Injection Pump End Plates and Blades.

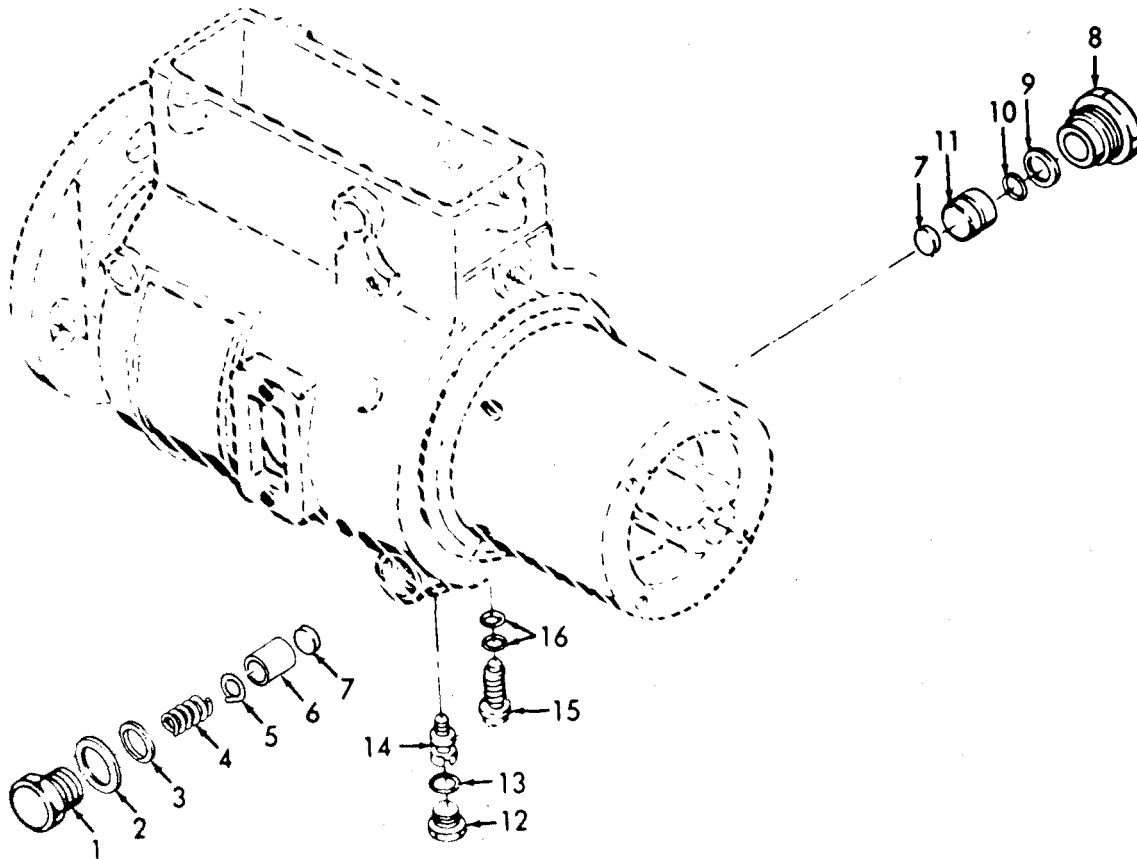


LEGEND FOR FIGURE 8-9:

ITEM	NSN	P/N	FSCM	QTY
1. Nut, Retainer	5310-00-791-9437	12288	84760	2
2. Packing, Preformed	5330-00-641-8286	11588	84760	2
3. Shaft		12214	84760	1
4. Pin		13554	84760	1
5. Rod Assy.		18275	84760	1
6. Spring		15617	84760	1
7. Arm Assy.		16573	84760	1
8. Barrel Assy.		16568	84760	1
9. Piston Assy.		16572	84760	1
10. Spring Damper		16574	84760	1
11. Cap Assy.		13567	84760	1
12. Packing, Preformed	5330	12966	84760	1
13. Guide		16629	84760	1
14. Washer		13572	84760	1
15. Packing, Preformed	5330-00-937-8477	13550	84760	1
16. Arm Assy.		14680	84760	1
17. Shim	5365-00-877-4952	11610	84760	1
18. Valve	2910-00-054-3816	20849	84760	1

Figure 8-9. Fuel Injection Pump, Pivot Shaft and Arm Assembly.





LEGEND FOR FIGURE 8-10:

ITEM	NSN	P/N	FSCM	QTY
1. Plug, Piston	5365-01-072-9280	12640	84760	1
2. Packing, Preformed	5330-01-014-6985	20113	84760	2
3. Packing, Preformed	5330-00-974-6643	12764	87460	2
4. Spring		14259	84760	1
5. Shim		12741	84760	1
6. Piston, Spring		14733	84760	1
7. Washer, Slide		12622	84760	2
8. Plug, Pipe		18968	84760	1
9. Ring		18967	84760	1
10. Gasket	5330-00-061-8538	15750	84760	1
11. Piston		16243	84760	1
12. Plug		12765	84760	1
13. Packing, Preformed	5330-00-936-4587	12766	84760	1
14. Screw	2910-00-787-6428	15438	84760	1
15. Cartridge	4820-00-432-1232	18547	84760	1
16. Packing, Preformed	5330-00-641-8283	11507	84760	2

Figure 8-10. Fuel Injection Pump Piston and Damper Spring.

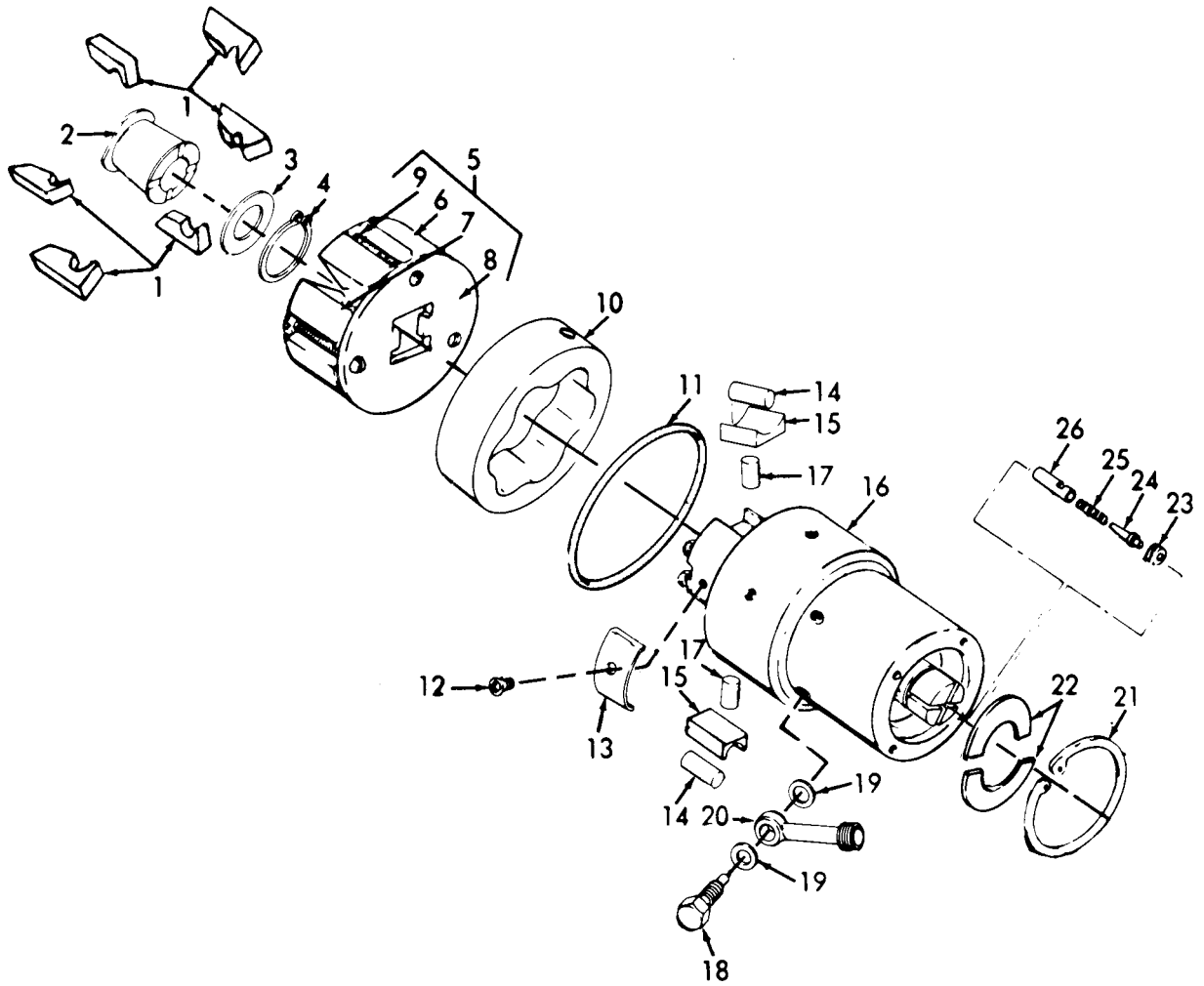


Figure 8-11. Fuel Injection Pump Rotor Assembly.

## LEGEND FOR FIGURE 8-11:

ITEM	NSN	P/N	FSCM	QTY
1. Weight		11658	84760	6
2. Sleeve		14483	84760	1
3. Washer, Governor		20222	84760	1
4. Ring	5365-00-804-2027	12285	84760	1
5. Retainer, Assy.		19610	84760	1
6. Retainer, Assy.		19528	84760	1
7. Retainer		19527	84760	1
8. Hub Assy.		18986	84760	1
9. Ring, Retaining		17513	84760	1
10. Ring		18785	84760	1
11. Packing, Preformed	5330-00-641-8291	11304	84760	1
12. Screw	5305-00-207-3984	11175	84760	1
13. Spring, Leaf		11196	84760	1
14. Roller, Cam		11141	84760	2
15. Shoe		20117	84760	2
16. Head and Rotor Pump	2910-00-054-3817	18770	84760	1
17. Plunger, Rotor		11076	84760	2
18. Bolt, Machine	4730-00-335-9315	11346	84760	6
19. Spacer, Ring	5310-00-891-8931	16225	84760	12
20. Connector		18770-1	84760	1
21. Ring		11208	84760	1
22. Retainer		11212	84760	2
23. Screw	5305-00-786-4032	13837	84760	1
24. Stop, Valve		16440	84760	1
25. Spring, Valve		13839	84760	1
26. Valve	2910-00-786-1547	13825	84760	1

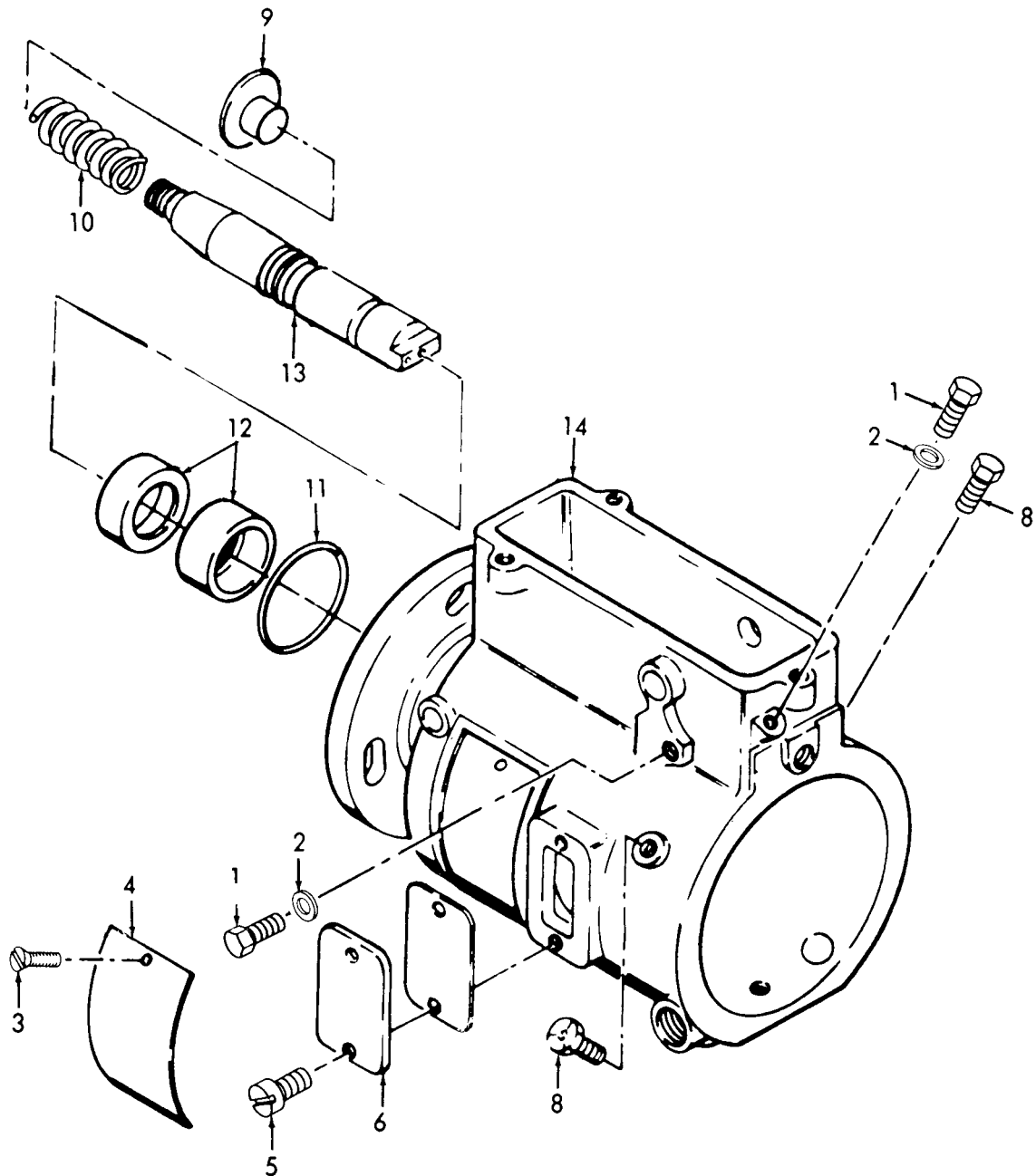


Figure 8-12. Fuel Injection Pump Housing and Drive Shafts.

## LEGEND FOR FIGURE 8-12:

ITEM	NSN	P/N	FSCM	QTY
1. Screw, Cap	5305-00-993-8748	12259	84760	2
2. Washer		10464	84760	2
3. Screw, Drive	5305-00-253-5606	MS21318-7	96906	2
4. Plate, Identification		10394	84760	1
5. Screw, Machine	5305-00-787-6468	10584	84760	4
6. Cover		10567	84760	2
7. Gasket, Timing	5330-00-506-3975	10574	84760	2
8. Bolt, Machine	5306-00-819-3038	11331	84760	2
9. Button, Thrust		10536	84760	1
10. Spring		10541	84760	1
11. Packing, Preformed	5330-00-877-4972	10519	84760	1
12. Packing, Preformed	5330-00-757-1680	10453	84760	2
13. Shaft		20286	84760	1
14. Housing Assy.		14846	84760	1

## NOTE

The sides of the housing just above the advance bears a "C" denoting clockwise pump rotation as viewed from the drive end. The power side of the piston is located on the "C" side of a clockwise rotation pump.

- (18) Invert the holding fixture in the vise. Grasp the hydraulic head firmly in both hands and withdraw with a slight rotary motion. Use caution not to drop the governor weights (1, figure 8-11).
- (19) To disassemble the governor, invert the hydraulic head and rotor assembly and let the governor weights (1, figure 8-11), governor thrust sleeve (2, figure 8-11) and governor thrust sleeve washer (3, figure 8-11) fall into your hand.
- (20) Place the hydraulic head assembly on pump holding fixture so that the governor weight retainer (5, figure 8-11) engages the bar on the fixture.
- (21) Remove pivot shaft nut (1, figure 8-9) and seal (2, figure 8-9) from one side of pivot shaft (3, figure 8-9). Slide pivot shaft out one side of the housing and lift out governor arm (7, figure 8-9).
- (22) Using a 5/32-inch Allen wrench, loosen the delivery valve retainer screw (23, figure 8-11) and remove it.
- (23) Lift head and rotor assembly and shake delivery valve stop (24, figure 8-11), spring (25, figure 8-11), and delivery valve (26, figure 8-11) into the hand. If delivery valve sticks, remove using extractor. Discard delivery stop.
- (24) Using a small-bladed screwdriver or a dull scribe, disengage and remove the rotor retainer snap ring (21, figure 8-11). This releases the rotor retainers which should now be moved outward as far as possible to clear the rotor.

## CAUTION

When the rotor retainers are removed, the rotor is no longer retained in the head.

- (25) Gently lift the hydraulic head off the distributor rotor. Invert the hydraulic head and shake out the rotor retainers (22, figure 8-11).

- (26) Lift off the cam ring (10, figure 8-11). Check and record the roller-to-roller dimension as instructed in the assembly procedures. This dimension should be 1.9640  $\pm$ 0.005 inches. Remove rollers (11, figure 8-11), (15, figure 8-11), plungers (17, figure 8-11), and leaf springs (13, figure 8-11). Discard spring screws (12, figure 8-11).

**CAUTION**

Do not handle rotor shank.

- (27) Remove governor weight retainer snap ring (4, figure 8-11) with snap ring pliers.
- (28) The flexible retaining ring (6, figure 8-11) should be replaced whenever the pump is disassembled. Insert the snap ring pliers, in the closed position, under rivets. Spread the pliers while applying pressure in an upward direction. A slight twisting motion will snap the ring off the rivet. Repeat the process until the retaining ring is free from all rivets. Discard the retaining ring.

d. Cleaning, Inspection, and Repair.

- (1) Inspect all springs, bores, grooves, and seal seats for wear, breakage, or damage. Repair or replace as necessary.
- (2) Carefully inspect transfer pump blades for chipping on any edges, pitting, imbedding foreign particles, or wear on the rounded ends. Visually check flat surfaces for scores. Determine blade wear by measuring the length (0.538 inches minimum).

**CAUTION**

Do not handle the rotor shank. Do not force the plungers into their bore.

- (3) While holding the rotor under fuel, insert the plungers into their bore. With thumb and forefinger over the guide slots, tilt the rotor from side to side several times to insure complete freedom of movement of the plungers. Interchanging or reversing their individual positions may be necessary, as these are mated parts. Replace defective parts. If plungers are not visibly damaged, clean them with a soft brush and a lacquer removing solvent such as lacquer thinner or acetone.
- (4) Examine the radii of the rotor, which is contacted by the leaf springs, and the weight retainer for wear. Check all slots, charging and discharge parts of the hydraulic head for chipping or erosion of edges. Check the rotor shank for scratches.

### NOTE

The rotor and hydraulic head are matched parts and shall be replaced as a unit.

- (5) Check the vent wire in the hydraulic head air bleed passage for freedom of movement. If the wire is free, flush the head and blow out all passages with clean, dry compressed air. If the wire is stuck, replace it after thoroughly cleaning the passages.
- (6) Check each cam roller for freedom of rotation in its shoe. Check each shoe for chipping or wear on the surface contacted by the leaf spring.
- (7) Check the leaf spring for cracks, nicks, chipping, or distortion. Check for damage and wear along rotor radii contact points and steps which retain roller shoes.
- (8) Examine the retainer sockets of governor weight for evidence of wear and damage. Replace the flexible snap ring (6, figure 8-9) of the weight retainer.
- (9) Inspect the pivot points of the governor arm (7, figure 8-11) pivot shaft for wear. Check the governor arm tabs at the point which contacts the thrust sleeve. If either tab is worn flat, replace the governor arm.
- (10 ) Examine the junction points of the metering valve pin hole in the linkage hook, throttle lever, shutoff cam, and shutoff lever for looseness and burrs.
- (11 ) Check the metering valve body for wear. Ascertain that the metering valve arm is well seated and there is not radial movement of the arm on the valve. Check the metering valve arm pin for wear or looseness.
- (12 ) Carefully inspect the bore and edges of all flat surfaces of the cam. If evidence of spalling or flaking out exists, replace the cam.

### NOTE

Since only the working portions of the cam lobes on the bore are ground, the tool marks between lobes should not be considered as damage. The cam finish is mottled from heat treatment rather than operation.



- (13) Visually inspect the drive shaft for undue wear or cracking. Check the diameter where the thrust sleeve slides for scores. Check for smoothness of seal grooves. They must be absolutely smooth.
- (14) Check the regulating piston for freedom of movement in the end plate sleeve. Check all threads for damage. The filter element should bear no evidence of damage. Clean all dirt or rust from the element.

**CAUTION**

Check for tightness of the orifice plate.  
Replace adjusting plug if plate is loose.

- (15) Check that the damper piston (9, figure 8-11) moves freely in the damper barrel (8, figure 8-11 ). Inspect for chipping of piston or scratches to the piston and damper barrel bore. The bleed orifice should allow free flow when the piston is inserted. Replace components as necessary.

e. Assembly.

**NOTE**

All parts should be flushed in clean oil as they are assembled. Replace all seals and gaskets.

**CAUTION**

Install piston seal dry. Do not use grease.

- (1) Insert regulating piston seal (9, figure 8-8) into the lower end of the regulating sleeve assembly (2, figure 8-8) far enough to expose retaining ring groove. Install retaining ring (6, figure 8-8) .
- (2) Install regulating piston (8, figure 8-8) and spring (7, figure 8-8 ) into the sleeve making sure that the piston slides to the bottom of the sleeve bore without binding.
- (3) Install end plate adjusting plug (1, figure 8-8 ) into the sleeve until all threads are just below port "A".

**CAUTION**

Do not exceed this position as excessive transfer pump pressure could occur.

- (4) Insert regulating sleeve assembly into the bore in end plate (14, figure 8-8).
- (5) Fit the transfer pump thrust plate (15, figure 8-8) on the end plate (14, figure 8-8).

#### NOTE

The thrust plate may be reversed if one side appears worn or scratched. A small amount of grease may be used to hold the thrust plate in place.

#### CAUTION

Do not use force when inserting rotor. Binding may be caused by the presence of foreign particles. If rotor binds, withdraw it, rinse the rotor and hydraulic head in clean fuel and attempt to assemble again.

- (6) Immerse rotor and hydraulic head (16, figure 8-11) in clean oil and assemble with a slight rotary motion.
- (7) Install delivery valve (26, figure 8-11) making sure that it moves freely in its bore. Install spring (25, Figure 8-11) and stop (24, Figure 8-11). Install screw (23, Figure 8-11) and torque to 85-90 inch-pounds.

#### NOTE

The screw (23, figure 8-11) has one end which is relieved to clear the delivery stop. Be sure that this end faces the stop.

- (8) Place the hydraulic head and rotor in the holding fixture. Insert plunger (17, figure 8-11) into the rotor bores. Install shoes (15, figure 8-11), roller (14, figure 8-11) and leaf springs (13, figure 8-11).
- (9) Adjust roller-to-roller dimension as follows: (See figure 8-13).

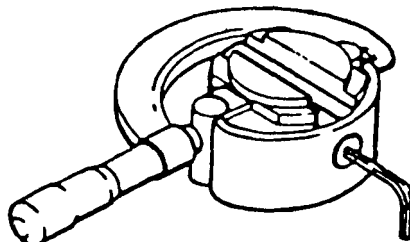


Figure 8-13. Adjusting Fuel Injection Pump Roller-to-Roller Dimension.

- (a) Apply clean, dry air at 30 to 100 pounds per square inch by means of a suitable fitting to any one of the head outlets.
- (b) Rotate the rotor until the rollers are pushed to their extreme outward position.

### NOTE

Turning screw clockwise increases the roller-to-roller dimension. Turning screw, counterclockwise reduces roller-to-roller dimension.

- (c) Using a 1 to 2 inch micrometer, measure the roller-to-roller dimension. If roller-to-roller dimension is not  $1.964 \pm 0.0005$  inch, adjust screw (12, figure 8-11).
- (10) Place the cam ring (10, figure 8-11) atop the hydraulic head, making sure that the rotation arrow points clockwise.
- (11) Place the governor weight retainer (5, figure 8-11) over the drive of the distributor rotor. Make sure that the assembly marks on the weight retainer and the rotor align with each other. Install retaining ring (4, figure 8-11).

### CAUTION

Use care when inverting the hydraulic head, as the rotor is not retained and could easily fall out.

- (12) Invert the hydraulic head in the holding fixture so that the governor weight retainer engages the bar.
- (13) Lift the hydraulic head slightly so that its inside face aligns with the rotor end and install retainers (22, figure 8-11). Install retaining ring (21, figure 8-11).
- (14) Insert the transfer pump liner (20, figure 8-8) into the hydraulic head so that the large slot is in line with the head locating screw hole and the letter "C", which signifies pump rotation, is up. This will correctly position the liner locating slot to accept the end plate locating pin.
- (15) Carefully insert the transfer pump blades (18, figure 8-8) and springs (19, figure 8-8) taking care not to cock them. Rotate the liner several times to check for freedom of movement. Return the liner to the correct position.
- (16) Install transfer pump seal (17, figure 8-8).

- (17) Slip the head and rotor assembly, drive end up, into the holding fixture. Place the six governor weights (1, figure 8-8) in their sockets with the slots facing the bore of the assembly. Place the thrust sleeve washer (3, figure 8-8) against the thrust sleeve (2, figure 8-8) so that the chambered edge faces the sleeve. Insert the forefinger into the bore of the sleeve and washer, holding them together, and insert them into the slots of the governor weights by tilting the weights slightly back. The two slots on the thrust sleeve flange should face up. Sight across the tops of the assembled weights to ascertain correct positioning. One weight higher than others indicates incorrect assembly of the thrust washer.
- (18) Place the governor arm (7, figure 8-9) in position with the fork for the governor linkage hook facing the end plate. Insert pivot shaft (3, figure 8-9) with the knife edge facing the end plate and assemble the two seals (2, figure 8-9) and nuts (1, figure 8-9). Tighten the nuts simultaneously to a torque of 20 to 25 inch-pounds.
- (19) Install a new seal (11, figure 8-11) on the hydraulic head. Rotate the cam ring so that the unthreaded hole is in line with the metering valve bore to insure proper positioning of the cam. Apply a light film of clean grease around the inside edge of the housing (14, figure 8-12).

**CAUTION**

Do not force. If the hydraulic head should cock during insertion, withdraw and start over.

- (20) Grasp the hydraulic head firmly in both hands and insert it into the housing with a slight rotary motion.

**NOTE**

Make sure that the assembly is put into position past the hydraulic head seal (11, figure 8-11). Failure to do this may result in leakage.

- (21) Rotate the hydraulic head until the head locking screw holes are aligned. Install head locking screws (8, figure 8-12) finger tight.
- (22) Invert the pump and holding fixture in the vise so that the bottom faces up.
- (23) Install seals (16, figure 8-10) and head locating screw (15, figure 8-10).

- (24) Install seals on piston plugs (1 and 8, figure 8-10).
- (25) Install piston ring seal (10, figure 8-10) and piston ring (9, figure 8-10).
- (26) Install cam advance screw (14, figure 8-10) using tool number 15500 and 15499 and torque to 400 in. lbs. Install seal (13, figure 8-10) and plug (12, figure 8-10).
- (27) Using the piston ring installing tool (part number 16199), slide power piston plug (8, figure 8-10) over piston (11, figure 8-8).
- (28) Install spring (4, figure 8-10), shim (5, figure 8-10), piston (6, figure 8-10), and slide washer (7, figure 8-10) into plug (1, figure 8-10). Install seal (3, figure 8-10) onto plug (1, figure 8-10).
- (29) Install plugs (1 and 8, figure 8-10) with their assembled parts into the housing and torque to 215 to 265 inch-pounds.

#### NOTE

Make sure that the power piston plug is on the right side of the pump as viewed from the transfer pump end.

- (30) Torque plug (12, figure 8-10) to 40 to 50 inch-pounds.
- (31) Torque head locating screws (14, figure 8-10) to 300 inch-pounds.
- (32) Torque head locking screw (1, figure 8-12) to 175 inch-pounds.
- (33) Invert the pump and holding fixture in the vise.

**CAUTION**

Never sand or polish off the special treatment on the valve.

- (34) Install the metering valve (18, figure 8-9) and shims (17, figure 8-9) into its bore. Depress and rotate the valve several times to insure freedom of movement. If valve sticks, lap it carefully in clean oil.
- (35) Metering Valve Setup:
  - (a) Install No. 11610 shim and No. 16575 spacer on metering valve.

- (b) Thread control rod guide No. 20223 into pump (finger tight).
- (c) Check clearance between valve and control rod guide. Add shim No. 16576 through 16583 (as required) to control clearance between 0 .002 in. and 0 .005 in. maximum.
- (36) Pull back on the governor linkage hook (29, figure 8-7) stretching the spring just enough to connect the hook correctly to the fork on the governor arm (7, figure 8-9). Position the other end over the pin on the metering valve arm (16, figure 8-9). Check all governor parts again for freedom of movement.
- (37) With the end plate (14, figure 8-8) removed, install the speed droop control rod through threaded hole from inside of pump housing.
- (38) Slide control rod guide (13, figure 8-9) with seal (15, figure 8-9), assembled over end of rod (5, Figure 8-9) and thread into the housing. Tighten securely.
- (39) Insert control spring pin (4, figure 8-9) into hole at end of rod (5, figure 8-9).
- (40) Assemble seal (12, figure 8-8) to groove at end of guide (13, figure 8-13) and install speed droop cap assembly (11, figure 8-8) over seal.
- (41) Install end plate (14, figure 8-8), making sure that guide pin (16, figure 8-8) enters the slot in the transfer pump liner (20, figure 8-8). Install flat washers (13, figure 8-8), lock-washers (12, figure 8-8), and screws (11, figure 8-8) and torque to 25 to 30 inch-pounds.
- (42) Thread five full turns of spring (6, figure 8-9) onto speed droop control rod (5, figure 8-9). Slip the free end of the spring over the formed ends of the governor arm (7, figure 8-9) with the bent-in ends of the spring between the two tabs.

#### NOTE

The apparent looseness in the governor parts is normal. Lost motion is immediately taken up as soon as the pump actuates.

- (43) Assemble the throttle shaft assembly (18, figure 8-7) with lever (14, figure 8-7) installed partially into position through the housing. Slide the spacer bushing (23, figure 8-7) and the throttle shaft lever (24, figure 8-7) over the throttle shaft so that the projection on the throttle shaft lever bore engages the keyway on the shaft. Position the throttle lever so that its forward tab straddles the linkage hook tab. Apply a light coat

of grease to the throttle and shut off seals (22, figure 8-7). Assemble the shutoff shaft assembly (10, figure 8-7) from the opposite side of the housing with a slight rotary motion. Locate and secure shutoff cam (1, figure 8-7).

- (44) Rotate the shaft until a click is heard. This is the governor arm (7, figure 8-9) engaging the governor thrust sleeve.
- (45 ) Check all governor parts for freedom of movement.
- (46) Assemble frame assembly (17, figure 8-6), spring sleeve (20, figure 8-6), spring (19, figure 8-6) and arm assembly (18, figure 8-6).
- (47) Install new insulating washers (15, figure 8-6), contact washers (14, figure 8-6) and locknuts (12, figure 8-6).
- (48) Install new gasket (11, figure 8-6) to cover (10, figure 8-6) and secure cover to pump with flat washers (8, figure 8-6), lockwashers (7, figure 8-9) and screws (6, figure 8-9).

f. Fuel Injection Pump Bench Test.

- (1) General. The bench test procedure is based on the following conditions:

- (a) Injection lines are 3/32-inch ID by 30-inches long.
- (b) Fuel readings are based on fuel with a viscosity of 34-36 SSU at 100°F.
- (c) Fuel temperature at 110 to 115°F.
- (d) Nozzles adjusted to opening pressure of 2500 psi (170 ATS).

- (2) Test procedure.

- (a) Mount pump securely in diesel injector test stand using a suitable adapter. The drive adapter, usually with a ball bearing, supports the shaft. This pump must be tested with an intermediate support bearing. Install high pressure injection lines using new gaskets. Leave fuel line connector screws at pump and injection line nuts at the nozzles loose. Install fuel inlet and return lines. Install transfer pump pressure gauge with a shutoff valve as close to the transfer pump as possible.

**NOTE**

Transfer pump pressure gauge must be isolated by shutoff valve at the fuel injection pump when checking fuel delivery and advance movement.

- (b) Set counter and tachometer switches to clockwise position.

**NOTE**

Pump runs at half the engine speed.

- (c) Start the test stand at lowest speed and check for clockwise rotation. Move throttle to full-load position. When transfer pump picks up suction, allow fuel to bleed for several seconds from loosened connector screws and injection line nuts, then tighten securely.
- (d) Operate pump at 500 rpm for 10 minutes. Dry off completely with compressed air.

**Table 8-1. Fuel Delivery**

PUMP	RPM	DELIVERY (mm <sup>3</sup> /stroke)	PRESSURE PSIG	MAX VAR BETWEEN CYLINDERS
900		56-59	70-75	3
750		55-58		4
927 (high idle)		15-20		

Observe for leaks and correct as necessary. Back out high idle stop screws.

**NOTE**

The inlet to the fuel transfer pump should never be pressurized during bench testing.

- (e) Close valve in supply line-transfer pump must pull at least 18 inches of mercury at 200 rpm. If it does not, check for air leaks on suction side or malfunction of end plate and transfer pump parts.
- (f) Fill graduates to bleed air from test stand and to wet glass.
- (g) Observe return oil. Return should be at rate of 100-450 cc/minute at 35 psig transfer pump pressure.



Under no circumstances should 130 psig be exceeded, as the pump will be damaged.



- (h) Operate pump at 900 rpm, with wide open throttle and observe transfer pump pressure. Pressure should be 70 to 75 psig. If it is not, use a hex key wrench and adjust pressure regulating spring by 1/4 turns, clockwise to raise pressure, counterclockwise to lower pressure.
- (i) Perform automatic advance check as follows:

#### NOTE

Each mark on the timing window is 2 pump degrees.

1. Check at 250 to 400 rpm for one degree cam movement.
  2. Drain burettes for 30 second minimum.
  3. Check at 450 to 550 rpm for 3-1/2 degree cam movement.
- (j) Perform speed droop adjustment as follows: (See table 8-1).
1. At 900 rpm and wide open throttle adjust high idle screw temporarily for 15-20 mm<sup>3</sup> delivery per stroke.
  2. Raise pump speed to 927 rpm and turn the droop adjustment cap assembly clockwise as viewed from the transfer pump end of injection pump to obtain a delivery of 15-20 mm per stroke.
  3. Lower pump speed to 900 rpm and check full load delivery rate. If 56-59 mm<sup>3</sup> delivery rate is not realized, repeat steps 1 and 2 above until 56-59 mm<sup>3</sup> is obtained.
  4. When step 3 requirements are met, lock the high idle adjusting screw.
- (k) Check delivery at 750 rpm. If delivery is not 55-58 mm<sup>3</sup> per stroke, repeat step (j) above until it is.
- (l) Raise pump speed to 950 rpm and check for a delivery rate of 5 mm<sup>3</sup> maximum delivery rate.
- (m) Lower pump speed to 900 rpm and de-energize the solenoid. Check for 5 mm<sup>3</sup> maximum delivery rate.
- (n) At the same speed, energize the solenoid and check the manual shutoff for the same delivery rate of 5mm<sup>3</sup> maximum.
- (o) At a pump speed of 200 rpm, repeat steps (n) and (9). Delivery shall be 2 mm<sup>3</sup> maximum.

(p) Check minimum cranking speed delivery as follows:

1. Check transfer pump for 8 psig minimum and close the shutoff valve to gauge.
2. Check for 35 mm<sup>3</sup> per stroke, minimum, at 75 rpm.

(g) Remove pump from stand.

g. Installation (Refer to figure 8-5).

- (1) Turn the engine over until the 20 degree before top dead center (BTDC) mark on the flywheel is lined up with the timing mark on the flywheel housing and No. 1 cylinder is on compression stroke.

#### NOTE

The pump shaft should never be turned backwards to align internal timing marks.

- (2) Remove the timing hole cover on the injection pump and rotate the pump shaft until the timing marks line up.
- (3) Install pump on engine and install attaching hardware finger tight.
- (4) Install drive gear on drive shaft of injection pump. Install lockwasher and nut, rotate shaft until timing marks are aligned and torque nut to 65 lb-ft.
- (5) Tighten nuts attaching injection pump to the engine.
- (6) Insert spring and thrust plug in hole in end of fuel pump drive shaft.
- (7) Install thrust plate gasket, thrust plate, washers and bolts. Tighten securely.
- (8) Install pump timing cover plate on the injection pump.

#### NOTE

When replacing fuel injector lines, always use new gaskets.

- (9) Install fuel injector lines.
- (10) Connect throttle linkage and stop control.
- (11) Connect fuel supply lines and return lines.

(12) Bleed air from the fuel system.

## 8-7. Fuel Injection Nozzle Holders and Lines.

### WARNING

The diesel fuel used in the engine for the Dynamotor-Welder is combustible. Use caution when draining/filling fuel tank and working on the fuel system. Extinguish all smoking materials and do not allow sparks or open flame near the fuel tank and fuel system.

#### a. Removal.

### NOTE

Locate faulty injectors as directed in sub-paragraph c below.

(1) Remove injector and return lines and fittings (13, figure 8-14).

### NOTE

Tag or otherwise identify lines and fittings and the location of support clamps to facilitate installation.

(2) Remove screws (1, figure 8-15) to remove injector nozzle holders (2, figure 8-15), seals, and nozzles (3, figure 8-15).

#### b. Cleaning and Inspection.

(1) Clean nozzle holders and lines with an approved solvent and dry thoroughly.

(2) Inspect nozzle holder assemblies for cracks, corrosion, signs of leaking, or other defects.

(3) Inspect lines for pinching, cracks, corrosion, and other damage.

(4) Check all threaded parts for stripping or otherwise damaged threads.

#### c. Testing.

(1) Loosen the fuel line at the injector on cylinder No. 1 until fuel flows freely from the break.

(2) If engine performance is affected, the injector is functioning properly.

(3) If engine performance is not affected, the injector is faulty and must be replaced.

(4) Tighten the injector fuel line.

(5) Repeat steps (1) through (4) for each injector.

(6) Remove faulty injectors in accordance with subparagraph a above.

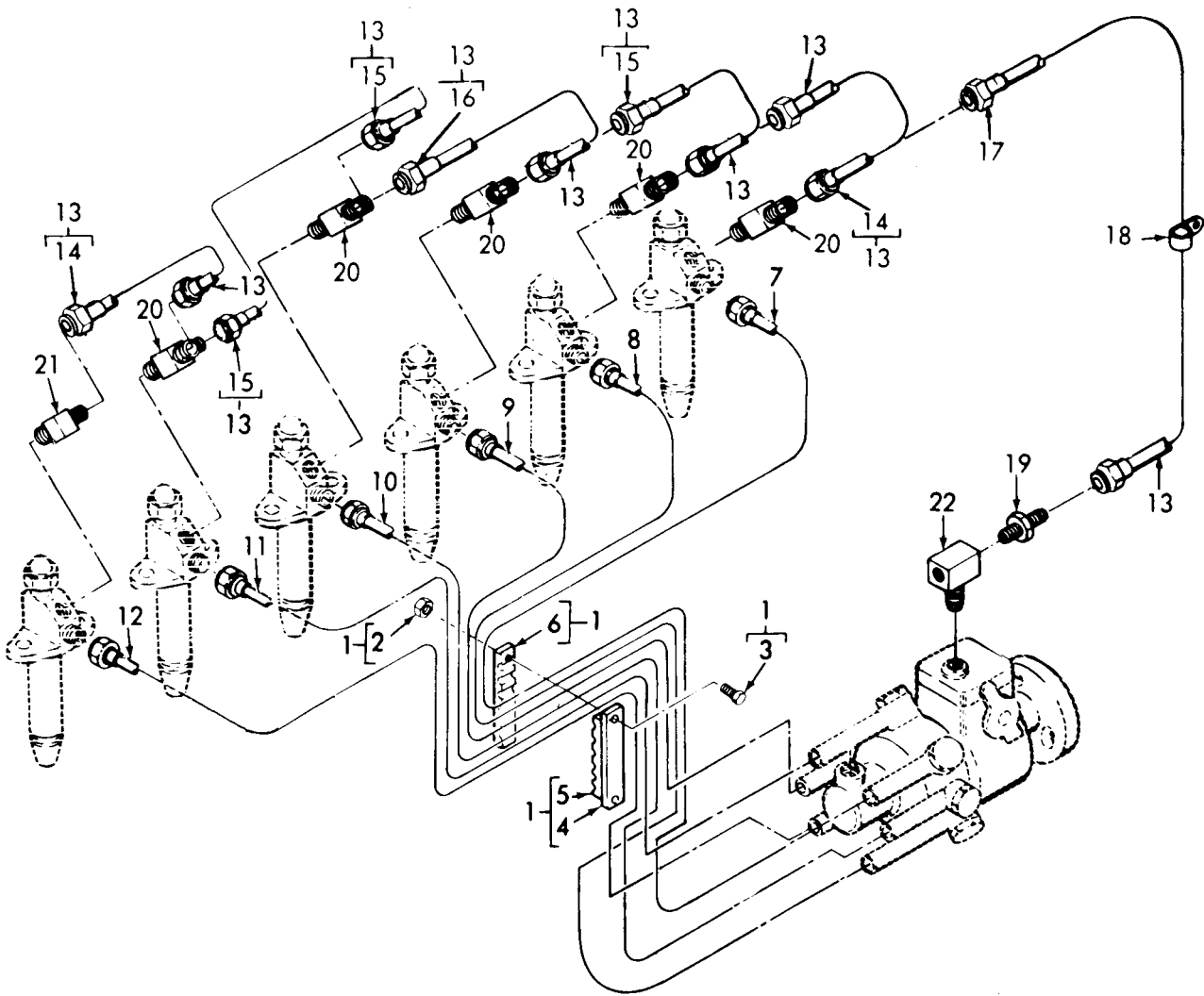
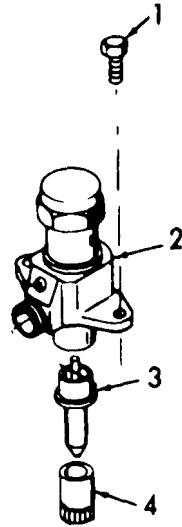


Figure 8-14. Fuel Injection Lines and Fittings.

## LEGEND FOR FIGURE 8-14:

ITEM	NSN	P/N	FSCM	QTY
1. Clamp, Assy.		40-3092754A	28265	1
2. Nut	5310-00-953-5600	13337A	28265	2
3. Screw, Cap	5305-01-071-2241	14395A	28265	2
4. Clamp		40-0007108A	28265	1
5. Insulation		40-0008501A	28265	2
6. Clamp		40-0007109A	28265	1
7. Tube Assy.	4710-00-739-6633	29065608	28265	1
8. Tube Assy.	4710-00-907-2297	291893DS	28265	1
9. Tube Assy.	4710-00-739-6634	290658DS	28265	1
10. Tube Assy.	4710-00-731-0132	290659DS	28265	1
11. Tube Assy.	4710-00-907-2300	291894DS	28265	1
12. Tube Assy.	4710-00-739-6637	290661DS	28265	1
13. Manifold Assy.		290662AS	28265	1
14. Tube Assy.		290577AS	28265	2
15. Tube Assy.		290515AS	28265	2
16. Tube Assy.		290516AS	28265	1
17. Tube Assy.		290663CS	28265	1
18. Clamp	2990-00-429-0524	3734A	28265	1
19. Coupling, Pipe	4730-00-415-3172	200744A	28265	1
20. Tee		203995A	28265	5
21. Elbow		203994A	28265	1
22. Tee	4730-00-595-0251	11721A	28265	1



LEGEND FOR FIGURE 8-15:

ITEM	NSN	P/N	FSCM	QTY
1. Screw, Machine	5306-00-364-2535	4728A	28265	12
2. Holder Assy.		291608A	28265	6
3. Nozzle, Fuel	2910-00-971-5568	291608A	28265	6
4. Holder, Nozzle		290588CS	28265	6

Figure 8-15. Fuel Nozzle and Holder.

- d. Lines Removal. Remove damaged fuel lines and fittings.

**NOTE**

It is not necessary to remove all fuel lines and fittings to replace a single part. Only those parts requiring replacement need be removed.

- e. Installation. Install fuel lines in reverse order of removal procedure.
- f. Disassembly.
- (1) Unscrew spray cap and remove pintle holder and pintle.
  - (2) Remove cap and washer.
  - (3) Remove locknut, adjusting screw, and washer to remove spring and spindle from body.
- g. Cleaning and Inspection.
- (1) Soak nozzle holder parts in a container of clean fuel and dry with a clean, lint-free cloth.
  - (2) Inspect pintle, pintle holder and spray cap for cracks, corrosion, erosion from fuel flow and other damage.
  - (3) Check body, spindle, and cap for cracks, corrosion, breaks, and other damage.
  - (4) Check spring for fretting, cracks, breaks, corrosion, and distortion.
  - (5) Check all threaded parts for cross, stripped, or otherwise damaged threads.
- h. Repair. Repair nozzle holder by replacing defective parts.
- i. Assembly.
- (1) Install spindle and spring into body.
  - (2) Install washer, adjusting screw and locknut.
  - (3) Insert pintle into pintle holder.
  - (4) Position pintle holder in body and secure with spray cap.
  - (5) Do not install washer and cap until after adjustment.

j. Testing and Adjustment.

- (1) Install repaired nozzle holder on a standard static fuel nozzle testing fixture.
- (2) Tighten adjusting screw all the way down.
- (3) Apply fuel at 2500-2950 psig and slowly loosen adjusting screw until nozzle begins to open.
- (4) Tighten locknut while holding adjusting screw with screw-driver.
- (5) Lower fuel pressure. Nozzle holder assembly shall close.
- (6) Slowly increase fuel pressure. Nozzle holder shall open at 2500-2950 psig.
- (7) Observe fuel spray. Fuel spray shall be even and smooth. Spray cone shall be same thickness at a distance of 5-inches. There shall be no signs of leakage.
- (8) Remove fuel pressure and remove nozzle holder from testing fixture.
- ( 9 ) Install washer and cap.

k. Installation. Install nozzle holders and lines in reverse order of removal. Sealing washers must be replaced at each removal.

**8-8. QUICK START SYSTEM.**

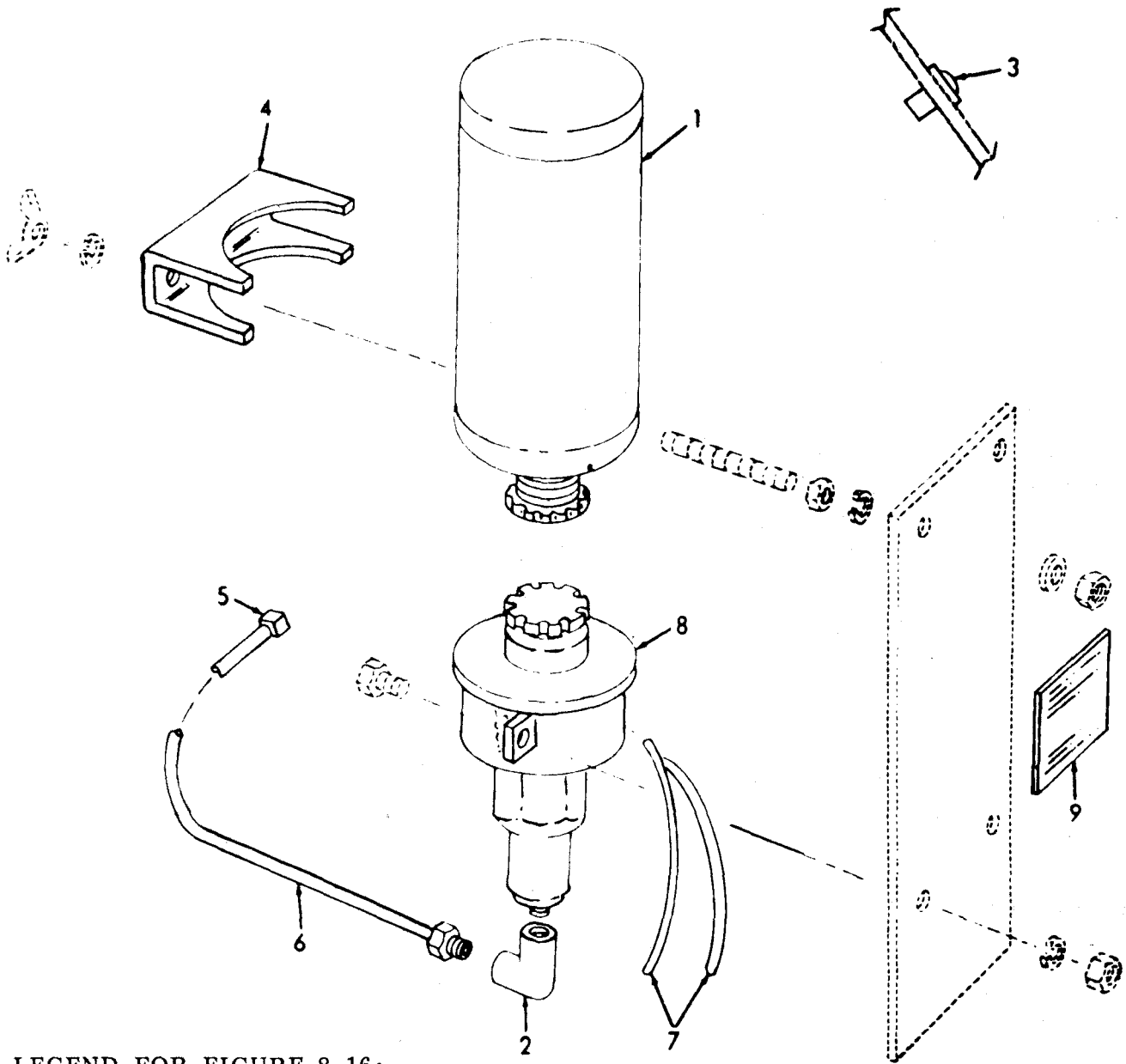
a. Removal. Remove the quick start system as shown in figure 8-16.

b. Cleaning and Inspection.

- (1) Clean components with an approved solvent and dry thoroughly.
- (2) Inspect parts for cracks, corrosion, signs of leaking or other defects.
- (3) Inspect line for finching, cracks, corrosion, or other damage.

c. Installation. Install the quick start system as shown in figure 8-16.





LEGEND FOR FIGURE 8-16:

ITEM	P/N	FSCM	QTY
1. Quick Start Fuel	LP535001	74384	1
2. Elbow	LP169001	74384	1
3. Switch Assy.	LP1779000	74384	1
4. Cylinder Clamp	LP2299000	74384	1
5. Atomizer	LP3238-1	74384	1
6. Tube, Nylon	LP3239048	74384	1
7. Wiring	LP3301000	74384	1
8. Valve	LP4578009	74384	1
9. Instruction	LP3662000	74384	1
10. Kit, Cold Start (Contains Items 1 through 9)	QS3285-799	74384	1

Figure 8-16. Quick Start System.



## CHAPTER 9

### ENGINE COOLING SYSTEM

---

**9-1. GENERAL.** The engine cooling system is a circulating pressure type system. It consists of a radiator, a belt driven cooling fan, and a centrifugal water pump, a coolant control thermostat, and a shutter assembly, which is part of the engine enclosure. The water pump receives coolant from the lower radiator hose and circulates it through the engine, the coolant absorbs heat generated by engine operation. When the engine reaches normal operating temperature, the coolant control thermostat opens and the coolant returns to the radiator through the upper radiator hose. As the heated coolant circulates through the radiator, the cooling fan blows air through the radiator air passages which dissipates the heat. The shutter assembly blocks the flow of cooling air until the coolant in the radiator reaches normal engine operating temperature.

#### **9-2. RADIATOR.**

a. Removal (Refer to figures 9-1 and 9-2).

- (1) Drain the cooling system.
- (2) Disconnect radiator coolant lines.
- (3) Remove fan guard.
- (4) Remove the fan assembly.
- (5) Remove the radiator.

b. Cleaning, Inspection and Repair.

**WARNING**

Always wear protective glasses when using compressed air to clean radiator air passages. Injury to the eyes may result from failure to observe this warning.

- (1) Clean foreign particles from the radiator core air passages with filtered compressed air.
- (2) Clean exterior surface of the radiator with cleaning solvent.
- (3) Visually inspect the radiator for excessive corrosion, cracked or broken brazing, and bent cooling fins.
- (4) Check interior of radiator for rust and scale deposits.
- (5) Test radiator for leaks as follows

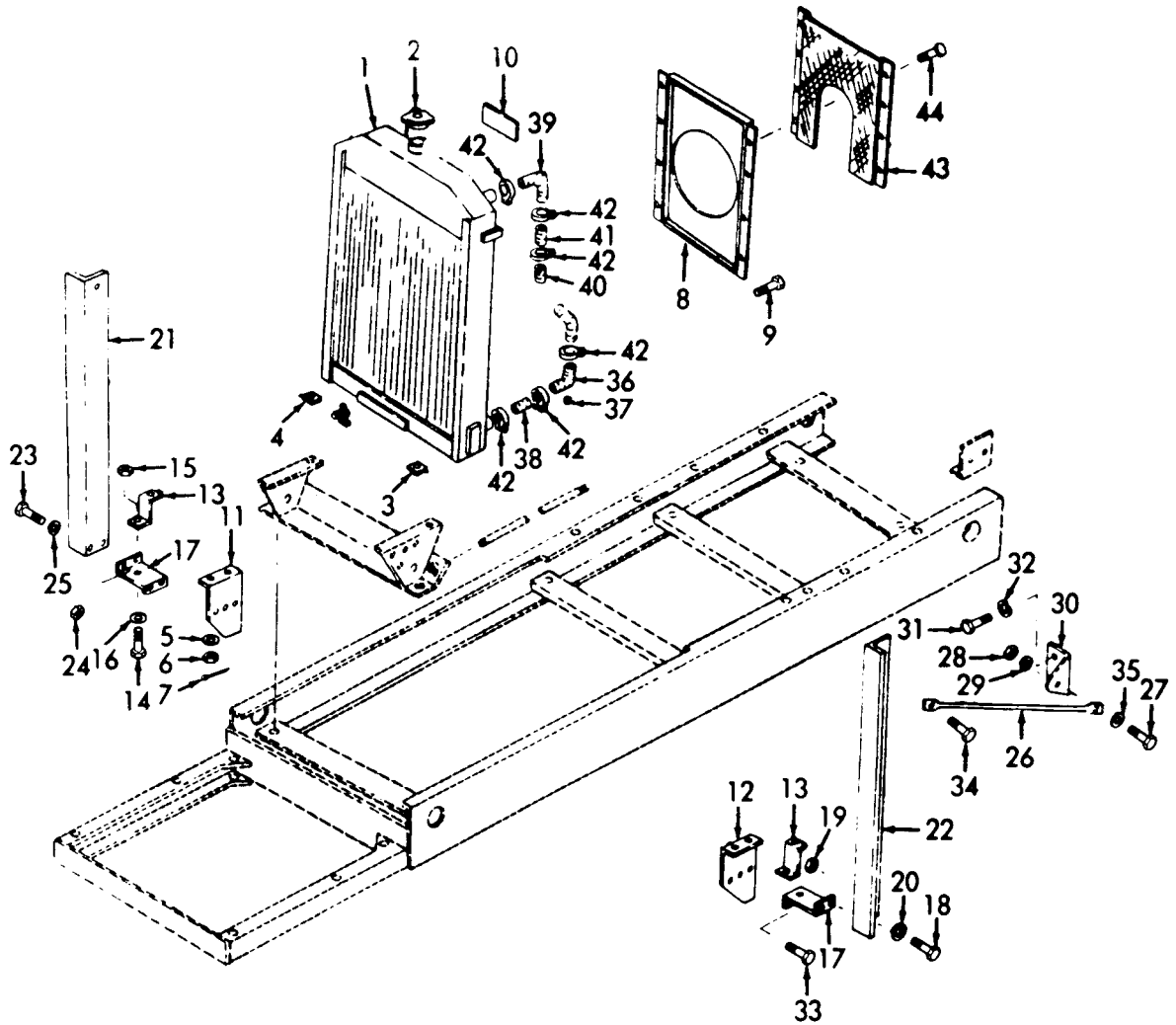
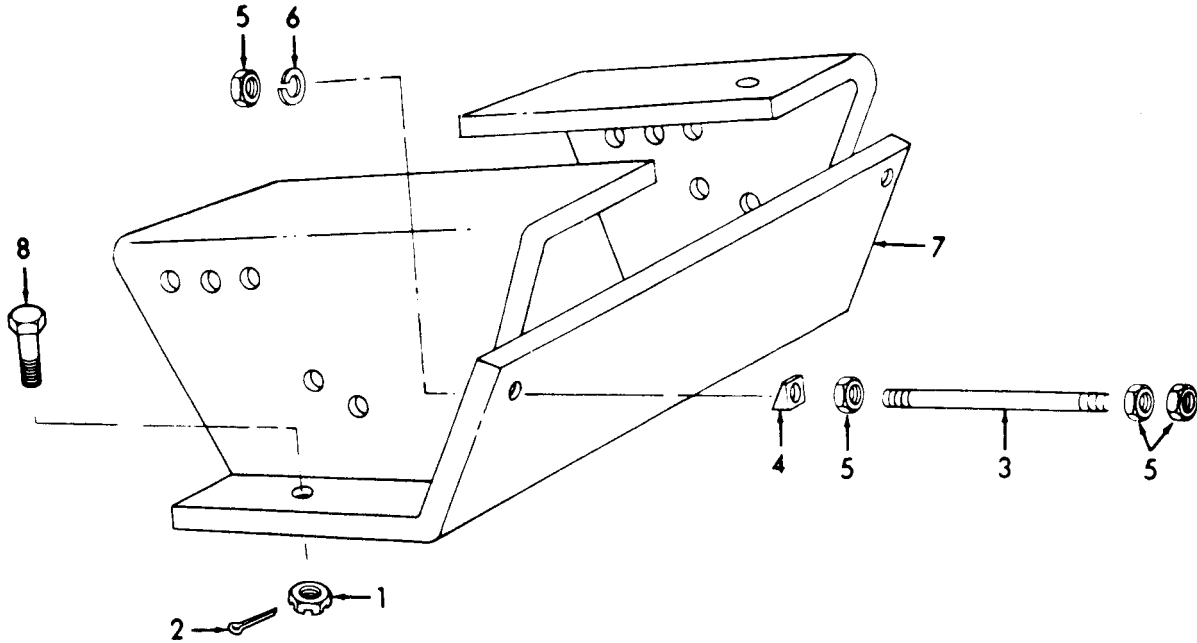


Figure 9-1. Radiator and Support Rods.

## LEGEND FOR FIGURE 9-1:

ITEM	NSN	P/N	FSCM	QTY
1. Radiator Assy.	4940-01-127-1113	40-3094052A	28265	1
2. Cap, Filler	2930-00-720-2677	1218048	00447	1
3. Pad, Mounting		203869A	28265	4
4. Pad, Mounting		29739A	28265	2
5. Washer, Flat	5310-01-072-4719	29750-A	28265	2
6. Nut, Plain	5310-01-071-2075	4-A	28265	2
7. Pin, Cotter	5315-00-059-0491	MS24665-372	96906	2
8. Shroud		40-3099001D	28265	1
9. Screw		6179A	28265	12
10. Plate, ID		208490A	28265	1
11. Support, RH		40-3091203D	28265	1
12. Support, LH		40-3091204D	28265	1
13. Bracket		40-00205278	28265	2
14. Screw, Cap	5305-01-007-6812	1000-12292	28265	4
15. Nut, Plain	5310-00-768-0321	MS51971-5	96906	8
16. Washer, Lock		2012-04024	28265	8
17. Brace		40-0020517C	28265	2
18. Screw, Cap	5305-01-077-8643	1000-12150	28265	4
19. Nut, Plain		1500-02222	28265	4
20. Washer, Lock		2012-04022	28265	4
21. Support Assy, RH		40-00205538	28265	1
22. Support Assy, LH		40-0020554C	28265	1
23. Screw, Cap	5305-01-077-8643	1000-12150	28265	4
24. Nut		1500-02222	28265	4
25. Washer		2012-04022	28265	4
26. Brace		40-00047068	28265	2
27. Screw, Cap	5305-00-912-5113	MS90726-59	96906	2
28. Nut, Plain	5310-00-732-0559	MS51968-8	96906	4
29. Washer, Lock	5310-00-637-9541	MS35338-9541	96906	4
30. Bracket		2879018	28265	2
31. Screw, Cap	5305-00-616-5649	315A	28265	4
32. Washer, Lock	5310-00-637-9541	MS35338-46	96906	4
33. Screw	5305-01-055-6738	1000-12293	28265	2
34. Screw	5305-01-086-7843	13255A	28265	2
35. Washer	5310-00-080-6004	MS27183-14	96906	2
36. Elbow		40-0002815C	28265	1
37. Plug, Pipe	4730-00-010-3867	415A	28265	1
38. Hose	4720-00-110-3663	4026224	09367	1
39. Elbow		2859888	28265	1
40. Hose	4720-00-288-9768	202110A	28265	1
41. Tube		40-00028138	28265	1
42. Clamp		2083938	28265	1
43. Guard		40-30978088	28265	1
44. Screw, Machine		6179A	28265	1



LEGEND FOR FIGURE 9-2:

ITEM	NSN	P/N	FSCM	QTY
1. Nut, Plain	5310-01-071-2076	1091/2-A	28265	2
2. Pin, Cotter	5315-00-234-1864	MS24665-302	96906	2
3. Tie Rod		40-3091501B	28265	2
4. Washer, Beveled	5310-01-072-0162	208700A	28265	4
5. Nut, Plain	5310-00-010-3030	1124A	28265	8
6. Washer, Lock	5310-00-054-8415	1126A	28265	8
7. Support Assy.		40-3091452J	28265	1
8. Screw, Cap Hex	5305-01-081-3099	40-0001344	28265	2

Figure 9-2. Front Support and Tie Rod.

- (a) provide an air line fitting at one of the radiator openings. Seal all other openings.
  - (b) Attach an airline to the fitting and submerge the radiator in a container of water.
  - (c) Pressurize the radiator to 10 to 15 psig and check for air bubbles which will indicate leakage.
- (6) Repair radiator as follows:
- (a) Straighten bent cooling fins.
  - (b) Remove light corrosion with number 00 grit abrasive paper.
  - (c) Repair leaks and cracked or broken brazing by brazing or soldering.
- (7) Replace radiator if damaged beyond repair.
- c. Installation. Install in reverse order of removal.

### 9-3. DRAINING, FLUSHING, AND REFILLING THE RADIATOR.

CAUTION

Never flush a cold system in cold weather. Warm the engine first to prevent the flushing agent from freezing on contact with cold metal. Do not disturb coolant lines when they are cold, as this could result in breakage of the lines.

- a. Draining.
- (1) Start the engine and run it slightly faster than idle speed until the water temperature is 180°F to 195° F.
  - (2) Stop the engine. Remove the radiator cap, remove drain plug located in the metal elbow at the lower radiator outlet hose and drain coolant. Install drain plug.
- b. Flushing and Neutralizing.
- (1) Fill radiator with clean water and the proper amount of approved cleaning compound. Install the radiator cap.
  - (2) Start the engine and run it slightly faster than idling speed for 30 minutes. After operating temperature is reached, drain the system as instructed in a.
  - (3) Repeat steps a(2) and b(1), substituting an approved neutralizer for the cleaning compound.

c. Refilling.

- (1) Fill radiator with clean fresh water and repeat steps given in paragraph 9-3a until water that is drained runs clean.
- (2) Fill cooling system with coolant. Start engine and run until temperature reaches 180° F. Observe coolant level and add coolant as necessary.
- (3) Install the radiator cap.

**9-4. RADIATOR HOSES AND TUBING.**

a. Removal.

- (1) Drain the cooling system.
- (2) To remove coolant line from thermostat housing to radiator, loosen the four clamps and remove the two hoses and the metal tube.
- (3) To remove the coolant line from the bottom of the radiator to the water pump, loosen four clamps and remove the two hoses and the metal elbow.

b. Cleaning and Inspection.

- (1) Clean all metal parts in cleaning solvent and dry thoroughly.
- (2) Clean all hoses in clean water.
- (3) Inspect all parts for damage, deterioration and corrosion.

c. Installation.

- (1) Install the radiator hoses, clamps and other coolant lines in reverse order shown in paragraph 9-4a.
- (2) Fill the cooling system.

**9-5. FAN BELT.**

a. Removal.

- (1) Loosen alternator mounting hardware.
- (2) Rotate alternator toward cooling fan until V-belt is slack enough to slip over alternator pulley.
- (3) Remove V-belt from fan pulley and crankshaft pulley.
- (4) Slip V-belt over cooling fan and slip between cooling fan and radiator.



b. Installation.

- (1) Install V-belt in reverse order of removal procedures.
- (2) Before tightening alternator mounting hardware, adjust belt tension as outlined in paragraph 9-5c.

Adjustment.

- (1) Loosen alternator mounting hardware.
- (2) Rotate alternator until firm pressure on V-belt midway between alternator pulley and water pump pulley will depress it approximately 1/2-inch.
- (3) Tighten alternator mounting hardware.

**9-6. FAN AND WATER PUMP ASSEMBLY.**a. Removal (Refer to figure 9-3).

- (1) Drain radiator.
- (2) Remove radiator hoses from water pump.
- (3) Remove cooling fan.
- (4) Remove capscrews and lockwashers to remove water pump and gasket.
- (5) Do not remove fan pulley unless inspection reveals damage.

b. Disassembly (Refer to figure 9-3).

- (1) Using a suitable puller, remove pulley hub.
- (2) Remove retaining ring (17).
- (3) Remove screws (2 and 18), lockwasher (3), and screw (5) to remove cover plate (19) and gasket (20).
- (4) Support front end of pump in bed of arbor press and press shaft bearing and flinger assembly (21) from impeller (22), seal assembly (23), and pump body (24).

**NOTE**

Shaft, bearing and flinger assembly (21) is a unit. Do not attempt to disassemble.

- (5) Press seal assembly (23) from pump body. Discard seal.
- (6) Disconnect water inlet housing (8) by removing screw (7) and lockwasher (6). Discard gasket (9).

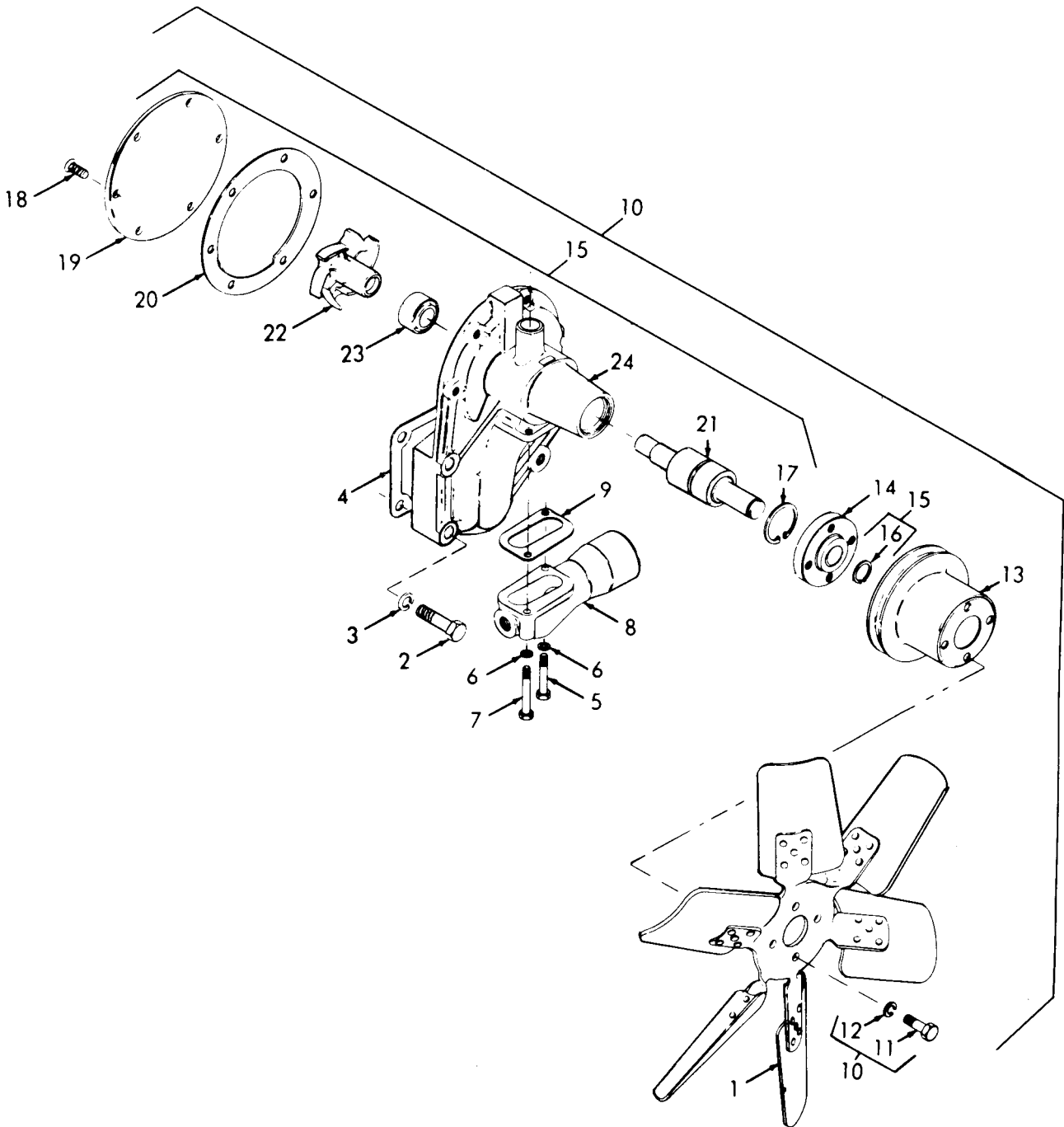


Figure 9-3. Fan and Water Pump Assembly.

## LEGEND FOR FIGURE 9-3:

ITEM	NSN	P/N	FSCM	QTY
1. Blade, Fan		286408C	28265	1
2. Screw, Cap	5305-00-786-4023	203518A	28265	3
3. Washer, Lock	5310-00-033-7566	335A	28265	3
4. Gasket		255360A	28265	1
5. Bolt Machine	5305-00-762-6238	204236A	28265	1
6. Washer, Lock	5310-00-407-9566	MS35338-45	96906	2
7. Bolt Machine	5306-00-463-0417	202886A	28265	1
8. Pipe, Inlet		285718C	28265	1
9. Gasket		255365A	28265	1
10. Pump Assy.	2930-00-962-7615	287370DS	28265	1
11. Screw, Cap		303A	28265	4
12. Washer, Lock	5310-00-407-9566	MS35338-45	96906	4
13. Pulley		2873728	28265	1
14. Adapter		2873718	28265	1
15. Pump Assy.		256290DS	28265	1
16. Ring	5330-00-784-0354	255359C	28265	1
17. Ring, Snap		11944A	28265	1
18. Screw, Machine	5305-00-619-2322	MS35265-96	96906	6
19. Cover		2553708	28265	1
20. Gasket		2553718	28265	1
21. Flinger Assy.		256581AS	28265	1
22. Impeller		2553618	28265	1
23. Seal		39187BS	28265	1
24. Body, Water Pump		255369D	28265	1
25. Kit, Repair (Contains Nos. 4, 9, 17, 20, 21, 22, 23)	2930-00-678-3818	255368CS	28265	1

c. Cleaning, Inspection, and Repair.

- (1) Clean all parts in cleaning solvent and dry thoroughly.
- (2) Visually inspect cooling fan pulley for cracks, corrosion, and excessive wear.
- (3) Check pulley hub for cracks, corrosion, and other damage.
- (4) Inspect cover plate for cracks, corrosion, and rub marks on inner face.
- (5) Inspect pump body for cracks, breaks, and excessive wear.
- (6) Inspect shaft and bearing assembly for deep water patterns, scores, pitting and other damage. Rotate bearing on shaft. If bearing is binding or reels rough, the shaft and bearing assembly must be replaced.
- (7) Check impeller for erosion, cracking, and other damage.
- (8) Replace any damaged or defective parts.

d. Assembly (Refer to figure 9-3).

**CAUTION**

When installing seal, press on outer flange to avoid damaging the seal.

- (1) Press replacement seal (23) into pump body (24).

**CAUTION**

When installing shaft and bearing assembly, press on outer bearing face and not on end of shaft.

- (2) Press shaft, bearing and flinger assembly (21) into pump body and install retaining ring (17 ).
- (3) Support pump on outer end of shaft and press impeller (22) onto shaft, bearing and flinger assembly to obtain 0.010 inch clearance between impeller and cover plate (fig. 9-4).
- (4) Install gasket (20) and cover plate (19 ) and secure with screws (3).
- (5) Press pulley hub (13 ) onto shaft (21) until shaft is flush with front of pulley.
- (6) Install water inlet housing (8) and new gasket (9) with screws (7) and lockwashers (6).

e. Installation. Install in the reverse order of removal.

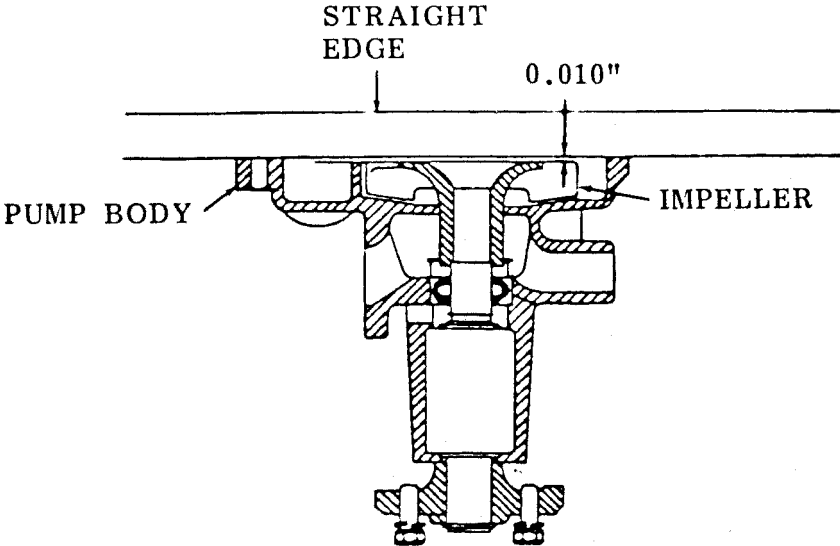


Figure 9-4. Checking Impeller to Cover Plate Clearance.



## CHAPTER 10

### ENGINE LUBRICATION SYSTEM

---

10-1. **GENERAL.** The oil system consists of an oil pump, oil filter, oil lines and pressure regulator valve. The oil pump forces the oil under pressure through a full-flow oil filter to the main oil header in the cylinder block. This oil header is a drilled passage extending the length of the cylinder block on the side opposite the camshaft and is closed at both ends with plug. From the main header oil is distributed under controlled pressure, through drilled passages to all main bearings, camshaft bearings and rocker arms. Oil for lubricating the connecting rod bearings is provided through drilled passages in the crankshaft from the main bearings. The cylinder walls, piston pins and valve tappets are lubricated by oil drain back and by the mist of oil thrown from the various pressure lubricated bearings. The gear train is lubricated by overflow oil from the camshaft. An external opening is provided for the connection of the oil pressure transmitter.

#### 10-2. OIL FILTER ASSEMBLY.

- a. Removal (Refer to figure 10-1).
- (1) Remove drain plug (23) and allow the oil to drain into a suitable container.
  - (2) Disconnect hose assemblies (24) and (25) from the filter assembly (10).
  - (3) Remove four nuts (2), lockwashers (3), flat washers (5), and cap screws (4) to remove oil filter clamp (14) from bracket.
  - (4) Do not remove bracket (8) unless inspection reveals damage.
  - (5) Remove the two elbows (1) from the filter housing.
  - (6) Remove square nut (11), flat washer (13) and screw (12), to remove clamp (14) from filter assembly (10).
  - (7) Refer to figure 10-1 and disassemble the oil filter assembly.
- b. Cleaning and Inspection.
- (1) Clean oil filter assembly parts with dry-cleaning solvent.
  - (2) Inspect mounting bracket for cracks, corrosion, and other damage.
  - (3) Inspect oil line assemblies for clogging, deterioration, or other damage.
  - (4) Check all threads for stripping or other damage.
  - (5) Replace any defective parts.

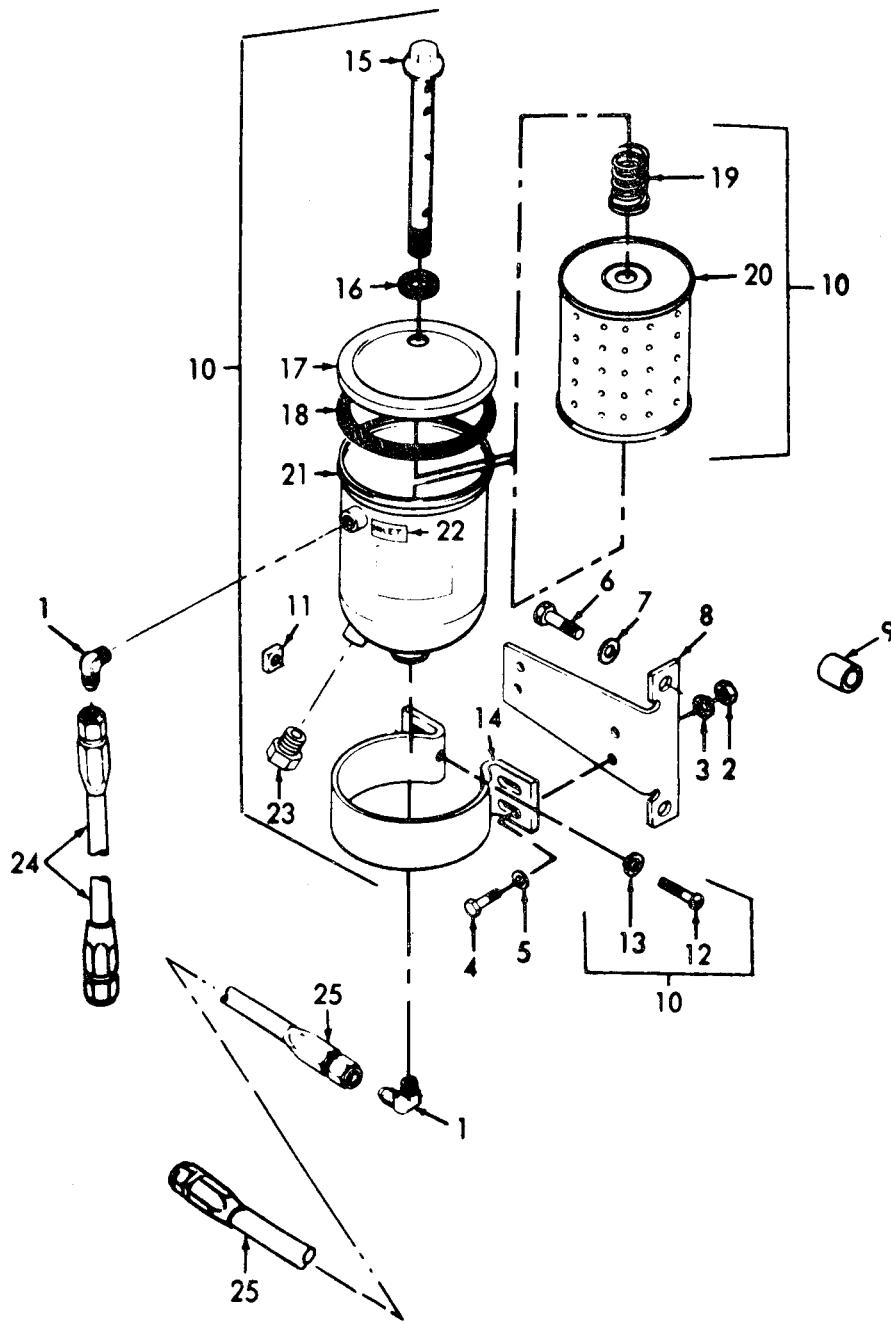


Figure 10-1. Oil Filter and Hose Assembly.



## LEGEND FOR FIGURE 10-1:

ITEM	NSN	P/N	FSCM	QTY
1. Elbow		4086A	28265	2
2. Nut	5310-00-268-6093	28A	28265	4
3. Washer, Lock	5310-00-407-9566	MS35338-45	96906	4
4. Bolt, Machine	5304-00-207-8348	3425A	28265	4
5. Washer, Flat	5310-00-081-4219	MS27183-12	96906	4
6. Screw, Cap	5305-00-543-2419	14058	28265	4
7. Washer, Lock	5310-00-637-9541	MS35338-46	96906	4
8. Bracket, Filter		286767A	28265	1
9. Spacer, Bracket	5340-00-400-0076	200087A	28265	4
10. Filter Assy.		290312CS	28265	1
11. Nut		154746	48228	1
12. Screw		151392	48228	1
13. Washer		151424	48228	1
14. Strap		152068	48228	1
15. Bolt and Valve		143863	48228	1
16. Washer, Flat	5310-00-297-2275	101979	73370	1
17. Cover		103326	48228	1
18. Gasket		102027	48228	1
19. Spring Assy.		118940	48228	1
20. Cartridge, Element		MS35802-2	96906	1
21. Body Assy		150015	48228	1
22. Decal		154100	48228	1
23. Plug, Drain		151728	48228	1
24. Hose Assy.		206795AS	28265	1
25. Hose Assy.	4720-00-221-0372	206796AS	28265	1

c. Installation.

- (1) Reassemble oil filter assembly (10) in reverse order of disassembly.
- (2) Install oil filter assembly (10) in reverse order of removal. Run engine. Check for leaks and correct oil pressure indication.

**10-3. OIL PAN ASSEMBLY.**

a. Removal (Refer to figure 10-2).

- (1) Remove the oil drain plug (5) and gasket (6). Drain the engine oil into a suitable container. If possible, drain the oil when the engine is at operating temperature.
- (2) If the starting motor is mounted below the oil pan level and will interfere with the oil pan removal, disconnect the electrical leads and remove the starter (para. 7-3a).
- (3) Support the oil pan and remove the bolts (1) and lockwashers (2). Remove the oil pan (3) and gaskets (12 ).
- (4) Remove front and rear oil seals (7).

b. Cleaning, Inspection, and Repair.

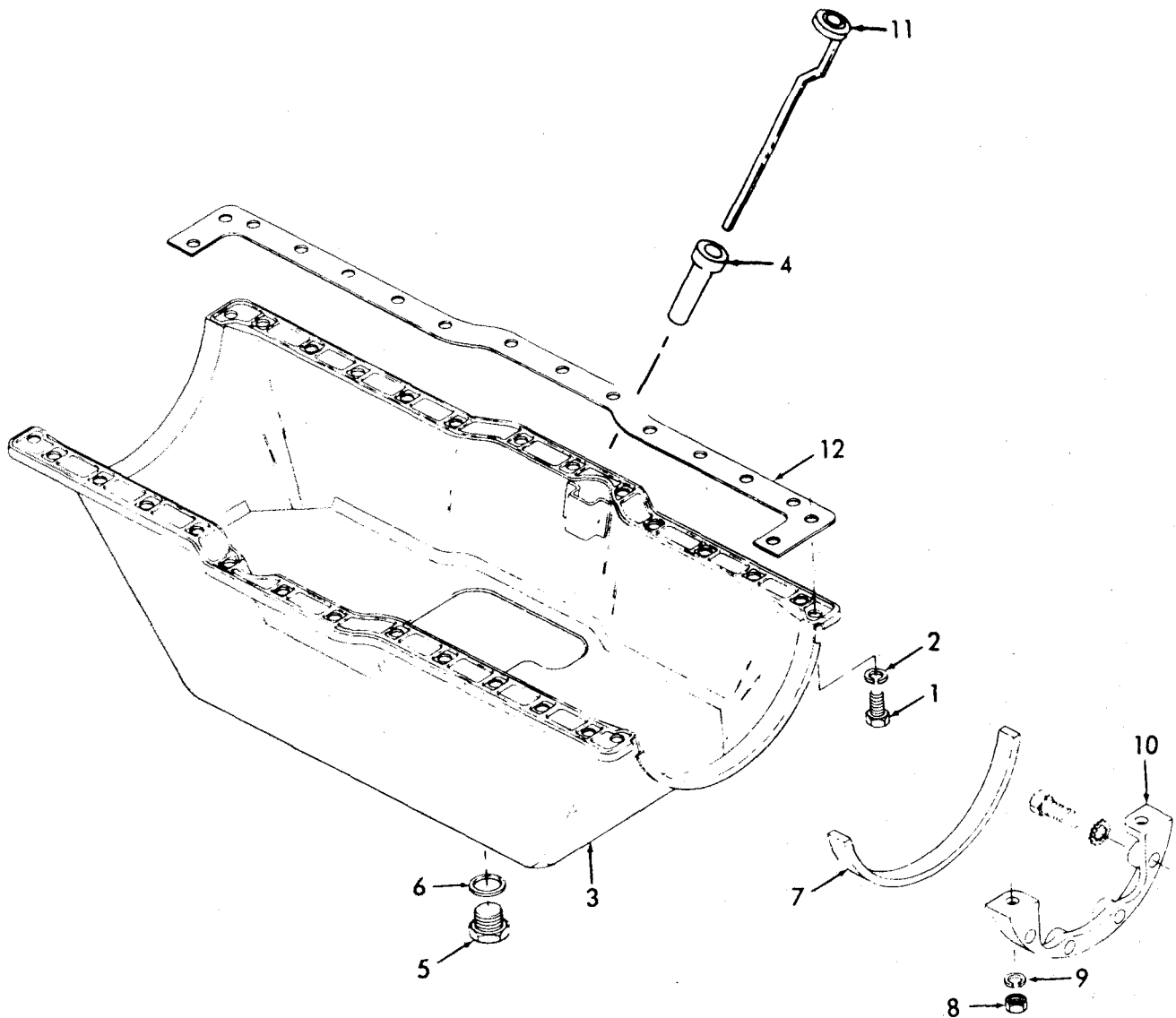
- (1) Clean all parts with cleaning solvent and a stiff bristle brush. Dry thoroughly with filtered, compressed air.
- (2) Scrape gasket remains from oil pan and cylinder block mating surfaces.
- (3) Inspect oil pan for cracks, dents, broken welds and leaks.
- (4) Check all threads for crossing, stripping and peening.
- (5) Repair cracks and broken welds in oil pan by welding.
- (6) Repair minor thread damage with a thread chaser.
- (7) Replace any parts damaged beyond repair.

c. Installation. Using new gaskets and seals, install oil pan assembly in reverse order of removal procedures.

**10-4. OIL PUMP ASSEMBLY.**

a. Removal (Refer to figure 10-3).

- (1) Remove oil pan assembly.
- (2) Remove screws (1) and lockwashers (2) to remove oil pump.

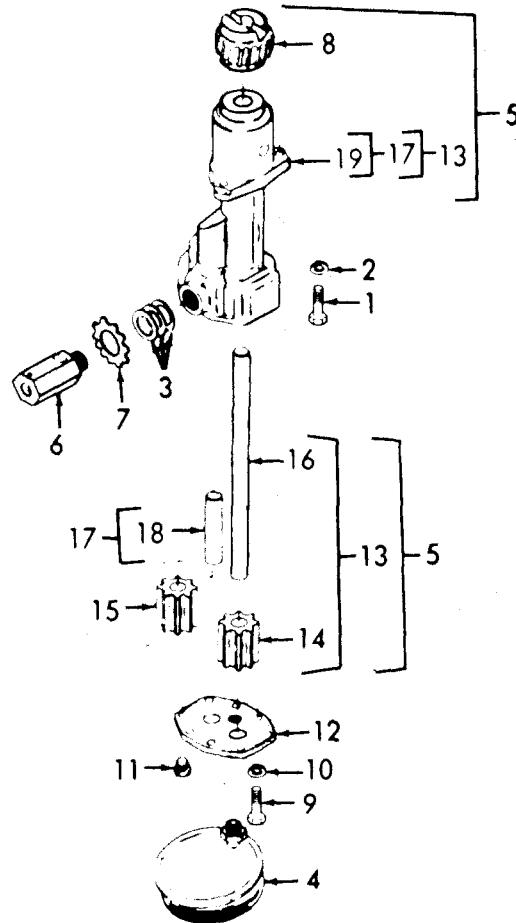


LEGEND FOR FIGURE 10-2:

ITEM	NSN	P/N	FSCM	QTY
1. Screw, Cap	5305-00-115-9526	4585A	28265	28
2. Washer, Lock	4310-00-637-9541	MS35338-46	96906	28
3. Pan Assy.		40-3018951D	28265	1
4. Tube, Dipstick		40-0018703B	28265	1
5. Plug, Machine Thread	5365-00-287-1527	14867A	28265	1
6. Gasket	5330-00-495-8290	296A	28265	1
7. Seal	5330-00-649-8437	255185A	28265	2
8. Nut, Plain	5310-00-268-6093	28A	28265	4
9. Washer, Lock	5310-00-407-9566	MS35338-45	96906	4
10. Adapter		255179B	28265	1
11. Gage, Bayonet		2602698	28265	1
12. Gasket	5330-00-678-3821	2851980	28265	2

Figure 10-2. Oil Pan.

- b. Disassembly (Refer to figure 10-3).
  - (1) Remove oil pickup screen (4).
  - (2) Remove pressure relief valve (6), lockwashers (7) and seal (3). Discard seal.
  - (3) Using a suitable puller, remove gear (8).
  - (4) Remove screws (9 and 11) and lockwashers (10) to remove cover plate (12).
  - (5) Remove driven gear (15).
  - (6) Withdraw drive gear (14) and drive shaft (16) as a unit.
  - (7) Press shaft (18) from pump body (19).
- c. Cleaning, Inspection, and Repair (Refer to figure 10-3).
  - (1) Clean all parts in cleaning solvent and dry thoroughly.
  - (2) Check gear (8) for chipped or broken teeth, excessive wear, or other damage.
  - (3) Inspect cover plate (12) for cracks and warpage. Check inner face for deep wear marks or scores from contact with gears.
  - (4) Inspect gears (14 and 15) for chipped or broken teeth, excessive wear, or other damage.
  - (5) Inspect shafts (16 and 18) for cracks, scores, and deep wear patterns. Check that shaft (16) rotates freely in pump body. Check that gear (14) rotates freely on shaft (18).
  - (6) Inspect pump body (19) for cracks, breaks, and other damage. Check gear bores for rub marks from contact with pumping gears.
  - (7) Check all threads for crossing, stripping, or peening.
  - (8) Inspect screen (4) for rips, tears, breaks, and clogging.
  - (9) Repair minor thread damage with a thread chaser.
  - (10) Remove minor nicks and burrs with crocus cloth and oil. Clean the part in dry cleaning solvent and dry thoroughly with filtered compressed air.
  - (11) Replace any parts worn or damaged beyond repair.



LEGEND FOR FIGURE 10-3:

ITEM	NSN	P/N	FSCM	QTY
1. Screw , Cap	5305-00-942-2196	1864A	28265	2
2. Washer, Lock	5310-00-637-9541	MS35338-46	96906	2
3. pacer	5365-00-929-1745	205354A	28265	1
4. Strainer		2852358	28265	1
5. Pump Assy.	4320-00-615-8598	40-3025071D	28265	1
6. Valve, Safety Relief	4820-00-622-5790	40-3092356B	28265	1
7. Washer, Key	5310-00-917-0963	285271A	28265	1
8. Gear, Drive		40-30754018	28265	1
9. Cap		14875A	28265	2
10. Washer, Lock	5310-00-582-5965	628A	28265	2
11. Bolt, Assembled	5306-00-916-6609	202536A	28265	6
12. Cover		2851848	28265	1
13. Pump Subassy.		287311DS	28265	1
14. Gear, Drive Shaft		2851948	28265	1
15. Gear, Idler Shaft		2873148	28265	1
16. Shaft		2862698	28265	1
17. Body and Shaft		287315AS	28265	1
18. Shaft, Idler		287313A	28265	1
19. Body		286303D	28265	1

Figure 10-3. Oil Pump Assembly.

d. Assembly (Refer to figures 10-3 and 10-4).

- (1) Press drive gear (14) onto shaft (16).
- (2) Insert shaft into pump body (19) and press gear (8) onto shaft **until a dimension of 4.84375 ±0.010 inches is obtained between** the mounting flange and the top of the drive flange (figure 10-4) .
- (3) Press shaft (18) into pump body and install driven gear (15).
- (4) Install cover plate (12) and secure with lockwasher (10) and screws (9 and 11).
- (5) Install new seal (3), Lockwashers (7), and pressure relief valve (6).
- (6) Check that drive shaft rotates freely. If shaft binds, disassemble pump and ascertain cause before installing.
- (7) Install pickup screen (4) and tighten.

**NOTE**

Pickup screen must be in the horizontal position when the pump is installed in the engine.

e. Installation.

- (1) Install oil pump, making sure that drive gear mates correctly with speed switch drive assembly.
- (2) Install oil pan.

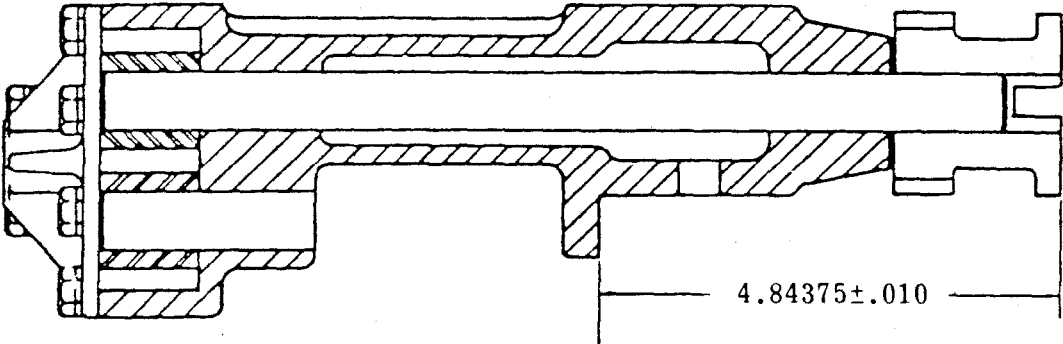


Figure 10-4. Oil Pump Assembly Dimension.





## CHAPTER 11

# INTAKE AND EXHAUST SYSTEMS

---

### 11-1. GENERAL.

- a. The intake system consists of a oil bath type air cleaner which removes dust and dirt from the engine combustion air.
- b. The exhaust system provides a means of expelling exhaust fumes from the engine and muffles much of the noise generated by engine operation.
- c. The breather tube provides an escape route for gases which accumulate in the crankcase during engine operation. The gases pass through the breather, located in the engine valve cover, and are expelled into the air cleaner housing through the breather tube.

### 11-2. AIR CLEANER ASSEMBLY.

- a. Removal.
  - (1) Remove air cleaner as illustrated in figure 11-1.
  - (2) Loosen clamp screw and clamp and remove oil cup (fig. 11-1) from the air cleaner.
- b. Cleaning and Inspection.
  - (1) Clean all metal parts with cleaning solvent and dry thoroughly.
  - (2) Inspect for dents, damage, and tears or defects in hoses. Replace defective parts as 'necessary.
- c. Installation.
  - (1) Install the air cleaner as illustrated in figure 11-1.
  - (2) Fill oil cup to proper level. Install the oil cup on the air cleaner and secure with clamp and clamp screw.

### 11-3. MUFFLER.

- a. Removal (Refer to figure 11-2).
  - (1) Loosen the raincap retaining screw (3), and remove the raincap (4), from the muffler (6).
  - (2) Remove the four screws that retain the exhaust pipe collar to the top of the engine housing and remove the collar.
  - (3) Remove the two nuts, washers and clamp (5), that retain the muffler (6), to the exhaust adapter (7).

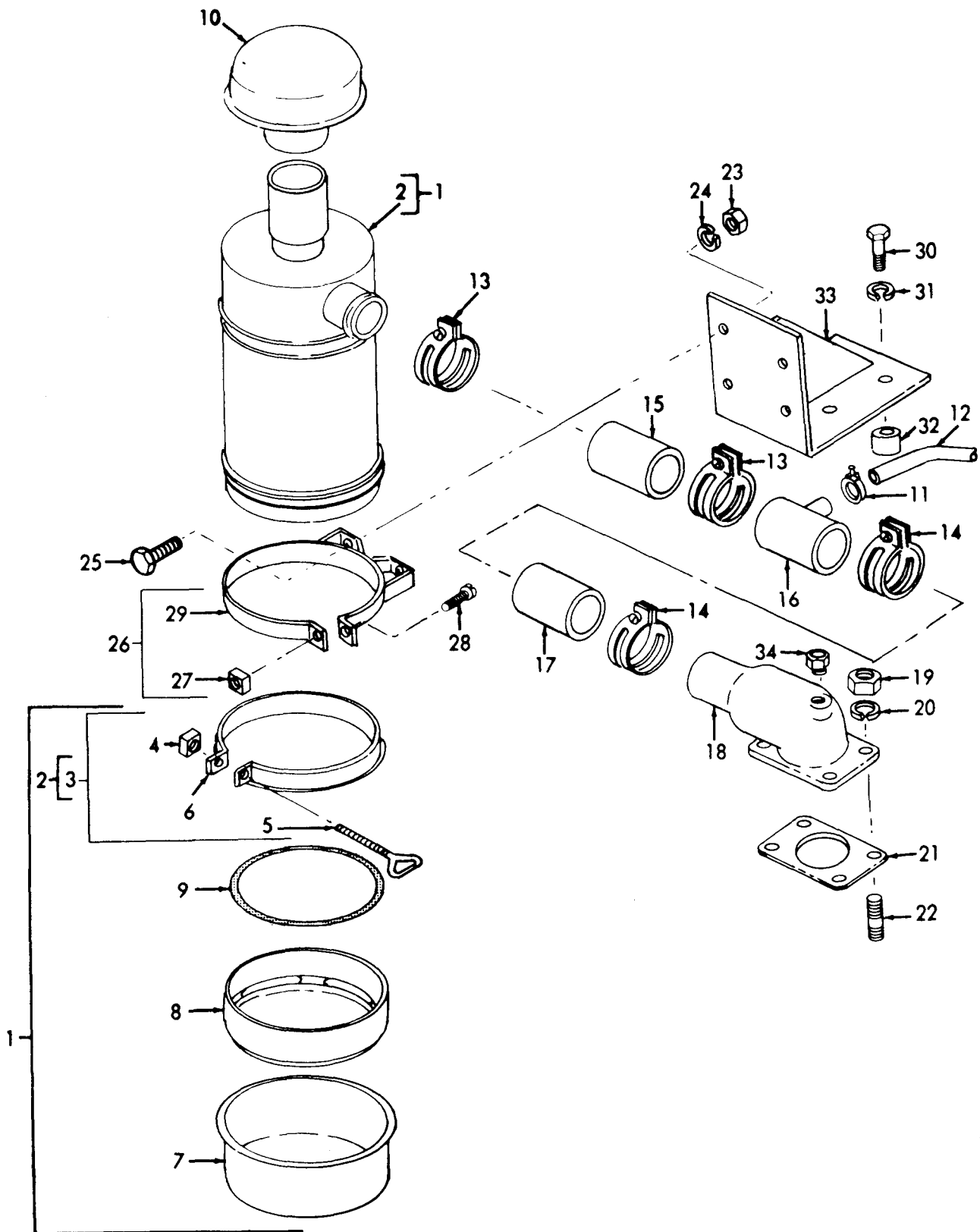


Figure 11-1. Air Cleaner and Tube.

## LEGEND FOR FIGURE 11-1:

ITEM	NSN	P/N	FSCM	QTY
1. Air Cleaner		FGA07-0031	18265	1
2. Body Assy.		P10-1312	18265	1
3. Clamp Assy.		P-10-1962	18265	1
4. Nut	5310-00-321-4677	MS21304-2	96906	1
5. Screw, Clamping		P19246	18265	1
6. Clamp		P10-1877	18265	1
7. Cup, Outer		P10567	18265	1
8. Cup, Inner		P10-1323	18265	1
9. Gasket		118265P-1324	51436	1
10. Cap, Rain	1040-00-190-0983	GAX00-1966	18265	1
11. Clamp, Loop		2083818	28265	1
12. Hose, Rubber		40-0020902	28265	1
13. Clamp, Loop		208396B	28265	2
14. Clamp, Loop		208392B	28265	2
15. Hose, Preformed	4720-00-930-4076	CS4720-00171		
		B219030	24161	1
16. Tube Assy.		40-0002857A	28265	1
17. Hose, Preformed	4720-00-288-9768	202110A	28265	1
18. Pipe, Inlet		40-3094202D	28265	1
19. Nut, Plain	5310-00-732-0559	MS51968-8	96906	4
20. Washer	5310-00-637-9541	MS35338-46	96906	4
21. Gasket	5330-01-026-6332	206231-A	28265	1
22. Stud		1151A	28265	4
23. Nut, Plain	5310-01-022-3082	61D06J	12603	4
24. Washer	5310-00-005-0620	11648629-3	19207	4
25. Screw, Cap	5305-01-077-8643	1000-12150	28265	4
26. Bracket Assy.		AAH00-0344	18265	2
27. Nut, Plain	5310-00-982-4938	MS21304-1	96906	1
28. Screw, Machine	5305-00-988-1726	MS35206-282	96906	1
29. Band		P4065	18265	1
30. Bolt, Special	5306-00-424-0605	1000-12362	28265	2
31. Washer, Lock	5310-00-584-5272	MS35338-48	96906	2
32. Spacer		207328B	28265	2
33. Bracket Assy.		40-0020555D	28265	1
34. Adapter		206880A	28265	1

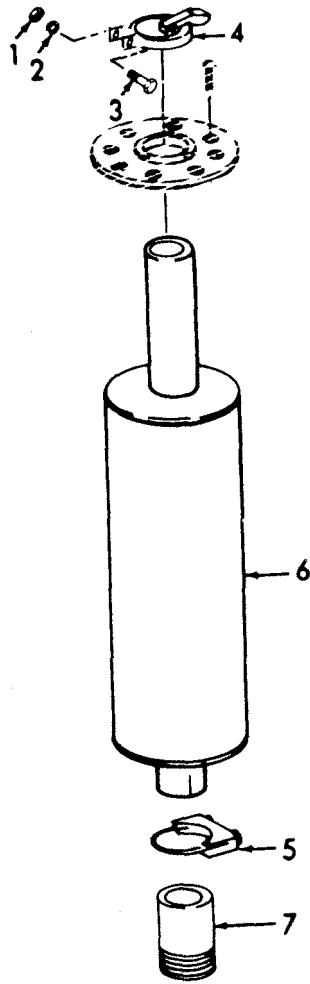
- (4) Remove the two screws that retain the exhaust flange to the manifold. Then, move the bottom of the muffler, with flange attached, away from the engine and downward so that the top of the muffler can be removed from its mounting hole in the top of the engine housing.
  - (5) Remove the exhaust flange from the muffler.
- b. Cleaning and Inspection.
- (1) Clean the exterior of the muffler assembly with cleaning solvent and dry thoroughly.
  - (2) Inspect for soft spots by pressing the shell, and for internal deposits of loose rust by shaking the muffler.
  - (3) Replace a defective muffler.
- c. Installation. Install the muffler in reverse order shown in paragraph 11-2a. Remove rust and parts of the old gasket from the exhaust flange and its mating surface of the manifold. Install new gasket.

#### 11-4. INTAKE MANIFOLD.

- a. Removal.
- (1) Remove air cleaner assembly.
  - (2) Remove nuts and lockwashers (fig. 11-3) to remove intake manifold and gaskets. Discard gaskets.
- b. Cleaning and Inspection.
- (1) Clean intake manifold with a stiff bristle brush and an approved solvent.
  - (2) Scrape all gasket remains from the mating surfaces of intake manifold and cylinder head.
  - (3) Inspect intake manifold for cracks, excessive corrosion and other damage.
  - (4) Check all threaded parts for stripped or otherwise damaged threads.
- c. Installation. Install intake manifold in reverse order of removal procedures. Torque nuts to 35 lb-ft.

#### 11-5. EXHAUST MANIFOLD.

- a. Removal.
- (1) Remove the muffler.



LEGEND FOR FIGURE 11-2:

ITEM	NSN	P/N	FSCM	QTY
1. Nut	5310-00-834-8736	MS35691-2	96906	1
2. Washer, Lock	5310-00-582	MS35338-44	96906	1
3. Screw, Cap	5305-00-225-3839	MS90725-8	96906	1
4. Cap, Rain	2990-00-122-0658	13217E0544-2	59678	1
5. Clamp		13217E0595	59678	1
6. Muffler	2990-00-740-6117	T-7519	76700	1
7. Adapter		13217E0572	59678	1

Figure 11-2. Muffler and Cap.

(2) Remove nuts and washers (fig. 11-3) to remove exhaust manifold and gaskets. Discard gaskets.

b. Cleaning and Inspection.

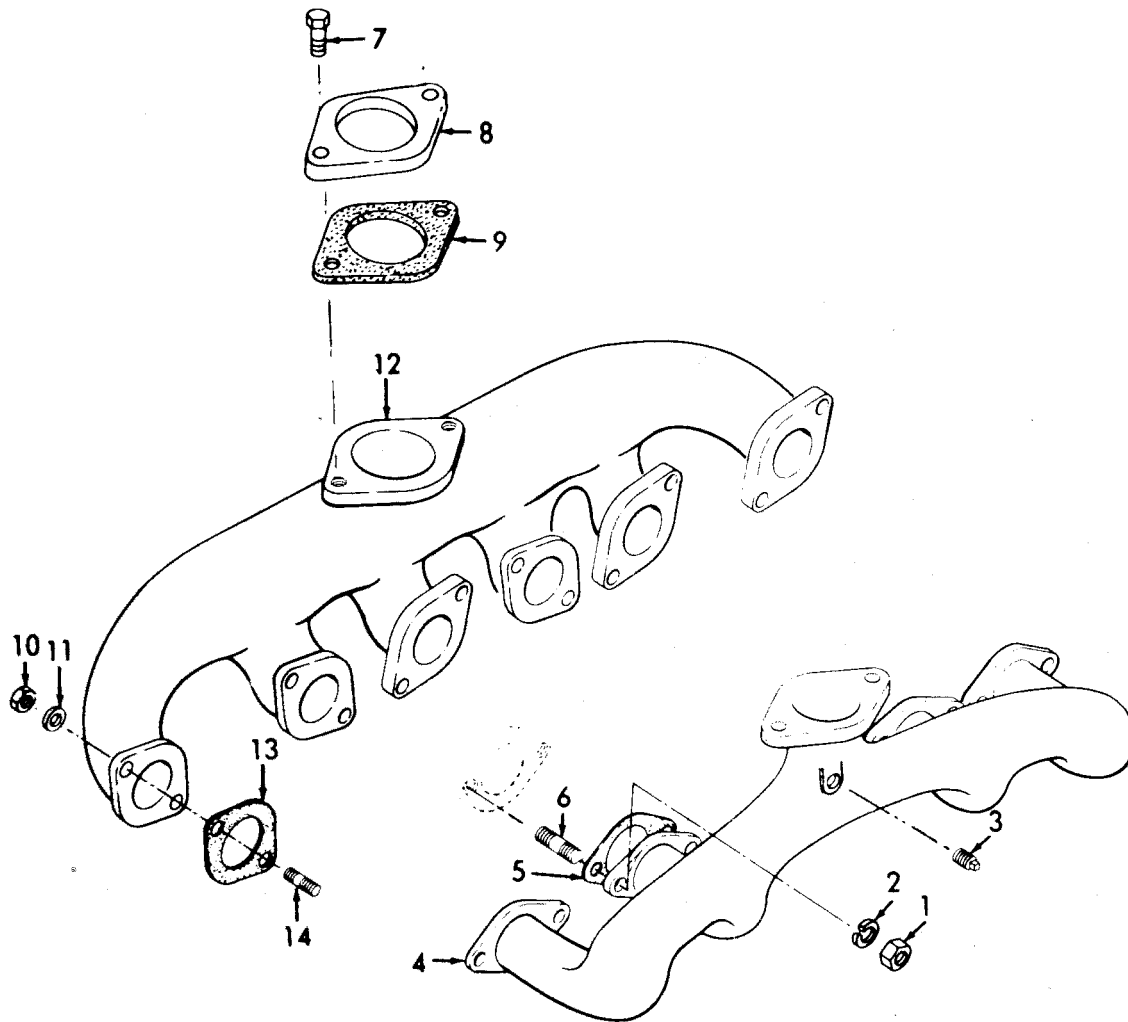
(1) Clean exhaust manifold with a stiff bristle brush and an approved solvent.

(2) Scrape all gasket remains from mating surfaces of exhaust manifold and cylinder.

(3) Inspect exhaust manifold for cracks, excessive corrosion, and other damage.

(4) Check all threaded parts for stripped or otherwise damaged threads.

c. Installation. Use new gaskets and install exhaust manifold in reverse order of removal procedures. Torque nuts to 35 lb-ft.



LEGEND FOR FIGURE 11-3:

ITEM	NSN	P/N	FSCM	QTY
1. Nut, Plain	5310-00-732-0559	MS51968-8	96906	4
2. Washer, Lock	5310-00-637-9541	MS35338-46	96906	4
3. Plug, Pipe	4730-00-289-0094	48X6	76894	1
4. Manifold, Intake		40-30300010	28265	1
5. Gasket, Intake	5330-00-291-8972	87A	28265	4
6. Stud, Plain	5307-00-916-6741	11662A	28265	4
7. Screw, Cap	5305-00-050-1076	MS90725-89	96906	2
8. Flange		40786A	28265	1
9. Gasket	5330-00-256-7003	40819A	28265	1
10. Nut, Plain	5310-00-033-5321	845A	28265	12
11. Washer	5310-00-464-2739	3306A	28265	12
12. Manifold, Exhaust		290330J	28265	1
13. Gasket	5330-00-171-7034	76026A	28265	6
14. Stud	5307-00-605-8227	13114A	28265	12

Figure 11-3. Intake and Exhaust Manifolds.





## CHAPTER 12

### ENGINE ASSEMBLY

---

#### 12-1. GENERAL.

- a. The engine assembly is a six cylinder, four cycle, fuel injected, compression ignition, liquid cooled diesel engine. The assembly consists of the cylinder head, rocker arm assembly, timing gears and housing, camshaft, flywheel and flywheel housing, main bearings and crankshaft, piston and connecting rod assembly, and cylinder block.
- b. The cylinder head is a one piece casting and is detachable. Valve seats are part of the casting, but valve guides are removable.
- c. The rocker arm assembly is mounted on the cylinder head. It functions to open and close the valves.
- d. The timing gears determine the sequence of valve opening and fuel injection. The gears are enclosed in a housing, the cover of which contains the front crankcase oil seal.
- e. The camshaft actuates the rocker arm assembly which operates the valves. It is driven by a gear which meshes with the crankshaft gear.
- f. The flywheel is made of cast iron. The flywheel is attached to the crankshaft by six bolts, one of which is off center. This permits the flywheel to be installed in only one position for timing purposes. The flywheel housing serves as a cover for the rear of the cylinder block and oil pan and as a partial enclosure for the flywheel. It provides the mounting for the starter assembly and also contains the rear crankshaft seal.
- g. The crankshaft has seven main bearing journals and six connecting rod bearing journals. This arrangement places each connecting rod journal between two main bearing journals. All bearing journals are surface hardened and are drilled for oil passages.
- h. The connecting rods are heavy alloy steel forgings with precision type bearings for the crankshaft and bronze bushings for the full floating piston pin. The pistons are made of aluminum and are the solid type (no saw slots or splits in the skirt). Each piston is fitted with five rings. The top three rings are compression type and the fourth ring from the top is an oil control ring. The fifth ring is an oil scraper ring.
- i. The cylinder block and crankcase are cast as a single unit giving ridged support for the crankshaft. Cooling is obtained by water jacketing the entire length of the block.

## 12-2. FLYWHEEL AND FLYWHEEL HOUSING.

### a. Removal.

- (1) Remove oil pan assembly (para. 10-3).
- (2) Remove bolt (1, figure 12-1) to remove flywheel (3) and ring gear (4) as an assembly. Do not remove ring gear unless it is badly damaged and replacement is necessary.
- (3) Remove nut (7), bolts (5), bolts (8), and lockwashers (6 and 9) to remove flywheel housing (10), and gasket (11). Discard gasket.
- (4) Using a suitable press, remove oil seal (12) from flywheel housing and discard.

### b. Cleaning, Inspection, and Repair.

- (1) Clean all parts in cleaning solvent and dry thoroughly. Remove caked grease deposits with a stiff bristle brush.
- (2) Inspect flywheel for cracks, nicks, and burrs. Remove minor nicks and burrs with crocus cloth.

### NOTE

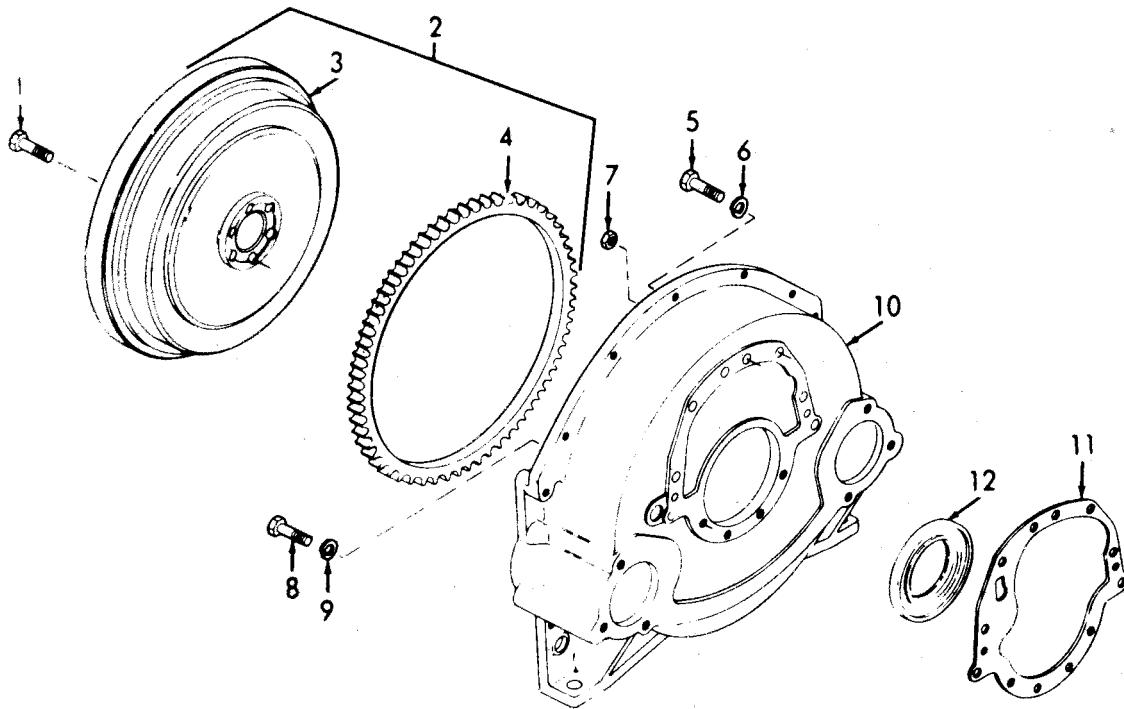
Rinse flywheel in dry cleaning fluid after dressing with crocus cloth. Crocus cloth contains ferrous oxide which will accelerate rusting of cast iron parts.

- (3) Inspect ring gear for cracks, chipped or broken teeth and other damage. If ring gear is badly damaged, replace as follows:
  - (a) Heat flywheel and ring gear in an oven at 450°F (232.2°C) for two hours.

**WARNING**

Wear asbestos gloves when handling heated flywheel to avoid serious burns.

- (b) Remove flywheel and ring gear and lightly tap ring gear to separate.
- (c) Heat replacement ring gear as in step (3) (a) above while freezing flywheel.



## LEGEND FOR FIGURE 12-1:

ITEM		NSN	P/N		QTY
1.	Bolt, Machine	5306-00-616-5620	40-00013148	28265	6
2.	Flywheel & Gear		40-3045952AS	28265	1
3.	Flywheel		40-3045902C	28265	1
4.	Gear, Ring		15471C	28265	1
5.	Screw, Machine	5305-01-053-6738	1000-12293	28265	6
6.	Washer, Lock	5310-00-584-5272	312A	28265	8
7.	Nut, Plain	5310-00-596-5086	201565	28265	2
8.	Screw, Cap	5305-01-014-4351	1865A	28265	4
9.	Washer, Lock	5310-00-400-8605	13595A	28265	4
10.	Housing, Bell		2854040	28265	1
11.	Gasket	5330-00-893-7799	2910350	28265	1
12.	Seal, Plain	5330-00-630-3567	40-0003206A	28265	1

Figure 12-1. Flywheel and Housing.

**CAUTION**

Wear asbestos gloves when handling frozen flywheel and heated ring gear.

- (d) Quickly install heated ring gear onto frozen flywheel.
- (4) Inspect flywheel housing for cracks, excessive corrosion, and defective paint.
  - (5) Repair cracks in flywheel housing by welding.
  - (6) Remove corrosion from flywheel housing with No. 00 grit abrasive paper soaked in oil. Clean flywheel housing with dry cleaning solvent after removing corrosion.
  - (7) Remove chipped paint, clean metal, and repaint as necessary.
  - (8) Replace oil seal each time flywheel housing is removed.
- c. Installation. Install flywheel and flywheel housing in reverse order of removal procedures.

**NOTE**

One flywheel bolt is off center to insure proper alignment.

**d. Testing.**

- (1) Turn crankshaft to top dead center (TDC) position.
- (2) Attach a dial indicator to flywheel housing and position so that foot rides on inner face of pilot bore (fig. 12-2).
- (3) Set dial indicator pointer to zero position.
- (4) Slowly rotate crankshaft one complete revolution.
- (5) Concentricity of pilot bore shall not vary 0.005 inch total reading.
- (6) Position dial indicator so that foot rides on outer face of flywheel (fig. 12-2).
- (7) Set dial indicator pointer to the "zero" position.
- (8) Slowly rotate crankshaft one complete revolution.
- (9) Alignment of flywheel shall not vary more than 0.005 inch total reading.
- (10) Replace flywheel if the above test requirements cannot be met.

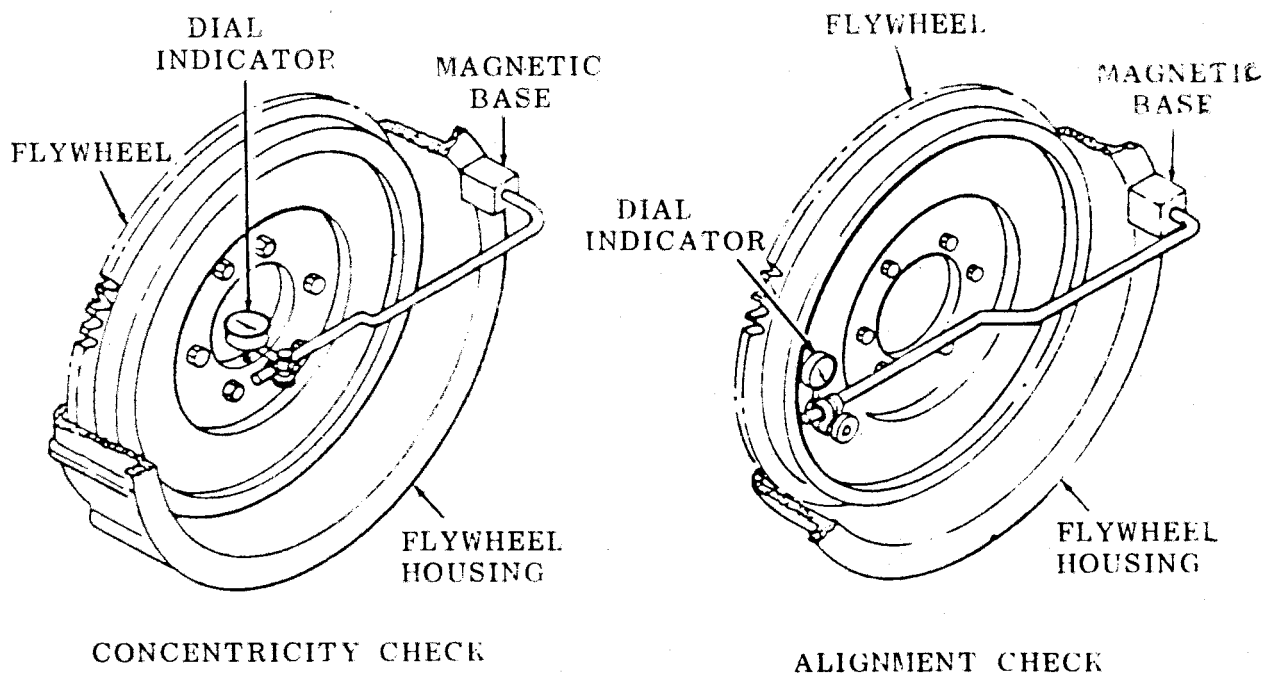


Figure 12-2. Checking Flywheel Concentricity and Alignment.

### 12-3. GEAR HOUSING AND COVER.

- a. General. The gear housing and cover mounted to the front of the engine covers the engine drive gears. The gear housing also forms the front support for the engine. The front oil seal for the crankshaft is also installed in the cover plate. The cover plate can be removed for inspection of the gears without removing the gear housing.
- b. Removal.
  - (1) Remove the nut (1, figure 12-3), lockwasher (2), and flat washer (3) that secure the fan drive pulley (6) to the crankshaft. Use a puller to remove the pulley and pulley cone (5). Remove the key (7).
  - (2) Remove the bolts (8, 10, and 11), lockwashers (9), and nuts (12 ) that secure the cover (14) to the gear housing. Remove the cover by pulling it away from the engine.
  - (3) Remove the thrust plate (19) and gasket (20) from the gear cover by removing four bolts (17) and lockwashers (18). Press the oil seal (21) from the gear cover.
  - (4) Remove the fuel injection pump.
  - (5) If it is necessary to remove the gear housing from the crankcase, proceed as follows:
    - (a) Drain the engine oil and remove the oil pan.
    - (b) Remove the front oil pan adapter by first removing the two nuts and lockwashers securing the adapter to the cylinder block and removing the four bolts and lockwashers securing the adapter to the gear housing.
    - (c) Remove the camshaft nut (27). To keep the shaft from turning, insert a brass bar between the crankshaft gear and the camshaft gear. Using a standard foot type puller inserted in holes in the gear, pull the camshaft gear (28) from the camshaft.
    - (d) Remove bolts (32 and 34) and lockwashers (33 and 35). Pull the gear housing away from the cylinder block. It may be necessary to tap the housing with a soft hammer to loosen it from the dowels or from gasket (40) sticking to the block.
- c. Cleaning , Inspection, and Repair.
  - (1) Discard all gaskets and seals.
  - (2) Clean the gear cover, housing, and attaching parts with cleaning solvent. Dry thoroughly. Make sure all old gasket material is removed from the gasket surfaces.

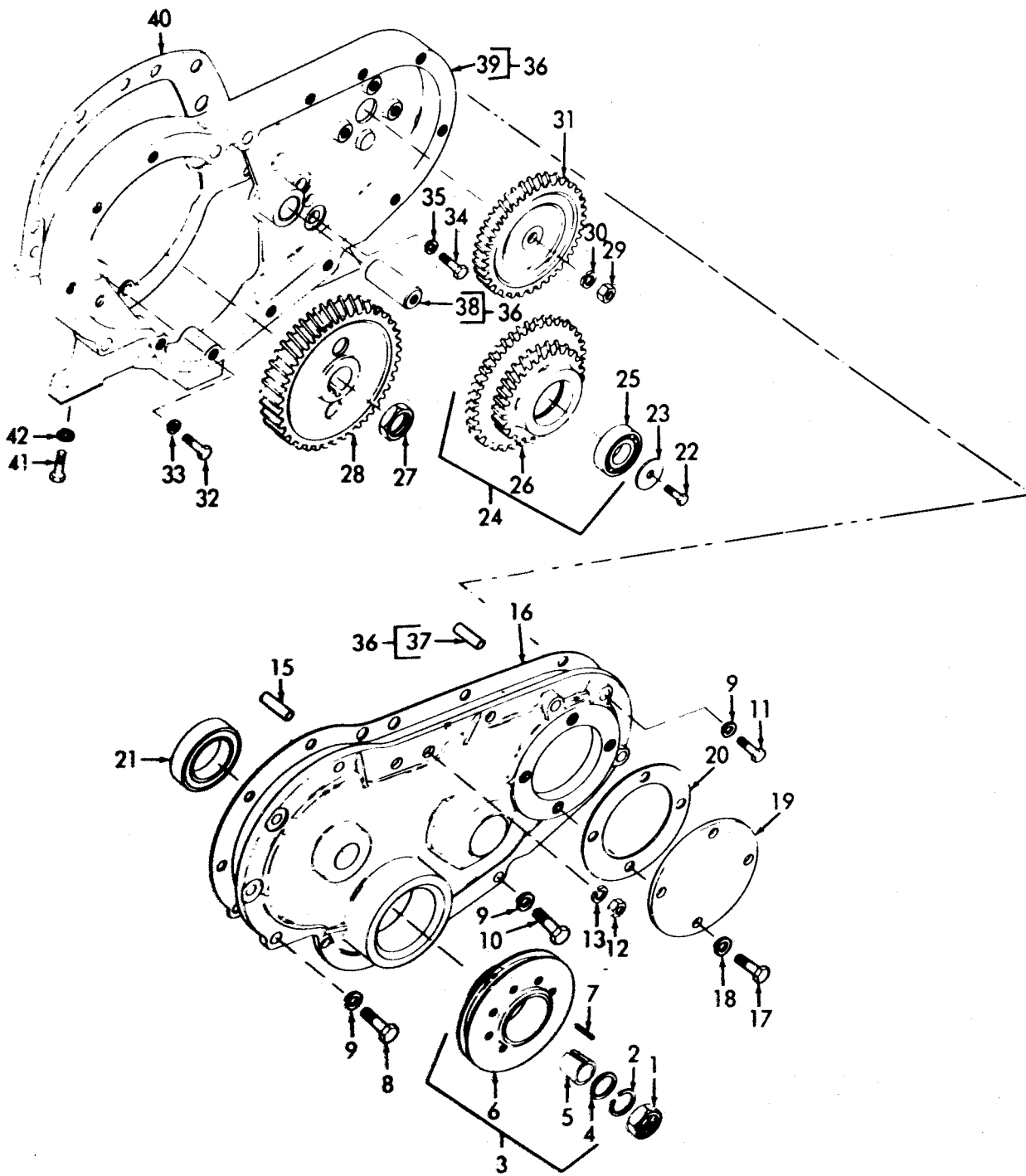


Figure 12-3. Gear Housing and Cover.

## LEGEND FOR FIGURE 12-3:

ITEM	NSN	P/N	FSCM	QTY
1. Nut, Plain	5310-00-420-6046	202568A	28265	1
2. Washer, Lock	5310-00-400-3495	1569A	28265	1
3. Pulley Assy.		287270B	28265	1
4. Spacer, Plate	5365-01-015-6800	287269A	28265	1
5. Hub, Pulley		287268A	28265	1
6. Pulley, Crank		287267C	28265	1
7. Key, Woodruff	5315-00-012-4553	1247A	28265	1
8. Screw, Cap	5305-00-616-5649	315A	28265	8
9. Washer, Lock	5310-00-637-9541	MS35338-46	96906	12
10. Screw, Cap	5305-01-014-4251	1865A	28265	1
11. Screw, Cap	5305-00-942-2196	1864A	28265	3
12. Nut, Plain	5310-00-596-5086	201565	28265	1
13. Washer, Lock	5310-00-584-5273	MS35338-48	96906	3
14. Cover, Housing		40-3015003D	28265	1
15. Dowel, Pin		2210A	28265	1
16. Gasket	5330-00-790-2659	2600460	28265	1
17. Screw, Cap	5305-00-616-5649	315A	28265	4
18. Gasket	5330-00-530-2523	76109A	28265	4
19. Plate, Thrust		2600478	28265	1
20. Gasket	5330-00-231-0283	76189A	28265	1
21. Seal	5330-00-598-8962	40-0003216A	28265	1
22. Screw, Cap	5305-01-017-5550	1000-24084	28265	1
23. Washer, Flat	5310-00-628-3874	40-0001517A	28265	1
24. Gear and Bearing		40-30755518	28265	1
25. Bearing Assembly	3110-00-596-3415	40-00123068	28265	1
26. Gear, Idler		40-3075501D	28265	1
27. Nut, Plain		255510A	28265	1
28. Gear, Helical	3020-00-614-6480	256070C	28265	1
29. Nut, Plain	5310-00-040-7974	2411A	28265	1
30. Washer, Lock	5310-00-167-0680	MS35338-49	96906	1
31. Gear, Fuel Pump		40-3075101D	28265	1
32. Bolt, Machine	5306-00-207-3510	14512A	28265	5
33. Washer, Lock	5310-00-523-2108	4731A	28265	2
34. Screw, Cap	5305-00-071-2074	MS90728-118	96906	1
35. Washer, Lock	5310-00-209-5116	MS35338-37	96906	2
36. Gear and Shaft		40-30155560	28265	1
37. Dowel, Pin		3673A	28265	1
38. Shaft, Idler		40-30957028	28265	1
39. Housing, Gear		40-30155060	28265	1
40. Gasket, Gear	5330-00-893-7799	2910350	28265	1
41. Screw, Cap	5306-00-364-2685	4728A	28265	1
42. Washer, Lock	5310-00-400-8605	13595A	28265	1



- (3) Inspect the gear cover and gear housing for cracks, distortion, and other damage. Replace either if damaged.
- (4) Check that gear housing dowel pins and stud in the cylinder block are tight and that the stud threads are in good condition. Replace any damaged parts.
- (5) Inspect the fuel injection pump drive gear, camshaft gear and idler gear for chipped, cracked, or broken teeth. Replace damaged gears.
- (6) Check the idler gear bearing for wear or rough operation. There should be just perceptible play in the bearing. Replace a worn bearing.
- (7) Check that the idler gear shaft is tightly fitted in the gear housing. It must withstand a direct pull of 32-pounds. Replace a loose-fitting idler gear shaft.

d. Installation.

- (1) If the gear housing was removed, install as follows:
  - (a) Cement a new gasket (40, figure 12-3) to the gear housing, allowing the cement to dry sufficiently to prevent the gasket from slipping at installation.
  - (b) Place the gear housing on the cylinder block; install the attaching bolts (32 and 34) and lockwashers (33 and 35) but do not tighten completely.
  - (c) Install the front oil pan adapter, securing it to the cylinder block with two nuts and lockwashers. Secure the adapter to the gear housing with four bolts and lockwashers. Tighten the gear housing bolts and nuts evenly and securely.
  - (d) Install the oil pan.
  - (e) Install the fuel injection pump
  - (f) Install the camshaft gear (28) on the camshaft, aligning the timing mark with timing mark on the crankshaft gear. Insert a brass bar between the camshaft and crankshaft gears. Pull down and secure the gear with the camshaft nut (27). Torque to 125-130 lb-ft.
- (2) Turn the crankshaft so that the flywheel timing marks indicate the required fuel injection pump timing position for the timing cylinder.
- (3) Install a new oil seal (21) in the gear housing cover, using a small amount of sealing compound in the bore before pressing in the seal. If a new seal is precoated, sealing compound is not required. Cement a new gasket to the gear housing cover.

- (4) Clean and polish the oil seal surfaces of the crankshaft to remove any nicks or scratches which could damage the seal. Use an oil stone or very fine emery cloth and polish with crocus cloth. If the shafts have a keyway which might damage the seal during installation, cover this keyway with a thin feeler gauge to protect the seal.
- (5) Apply a thin coat of oil soap to the seal and the seal surface of the crankshaft. If seal is already oil treated, additional lubrication is not required; however, take care to keep the seal surface clean during reassembly. Carefully place the oil seal over the crankshaft to install the cover (14) on the gear housing. Secure with bolts (8, 10, and 11), nuts (12), and lockwashers (8).
- (6) Install the fan drive pulley (6), key (7), and cone (5). Pull down and secure the pulley with the crankshaft nut (1), lockwasher (2), and flat washer (3). Torque nut to 125 lb-ft.
- (7) Install the thrust plate (19) and gasket (20) on the gear cover and secure with bolts (17) and lockwashers (18).

#### 12-4. CYLINDER HEAD AND ROCKER ARM COVER.

a. Removal.

- (1) Remove the air cleaner assembly (para. 11-2), and coolant control thermostat (para. 7-4).
- (2) Remove manifolds (paras. 11-3 and 11-4) and injector nozzles (para. 8-7).
- (3) Remove nuts (25, figure 12-4) and lifting eyes (24),
- (4) Remove nuts (7) and washers (8) to remove rocker arm assembly and push rods (18).
- (5) Remove nuts (19) and washers (20).

**CAUTION**

Tap cylinder head lightly with a soft hammer to loosen it. Do not pry on contact surfaces.

- (6) Lift cylinder head (26) from engine.
- (7) Remove and discard gasket (21) .

b. Disassembly.

- (1) Remove retaining rings (9) to remove mounting blocks (10), spacers (14 and 15), rocker arm (11), and springs (13) from shaft (16).

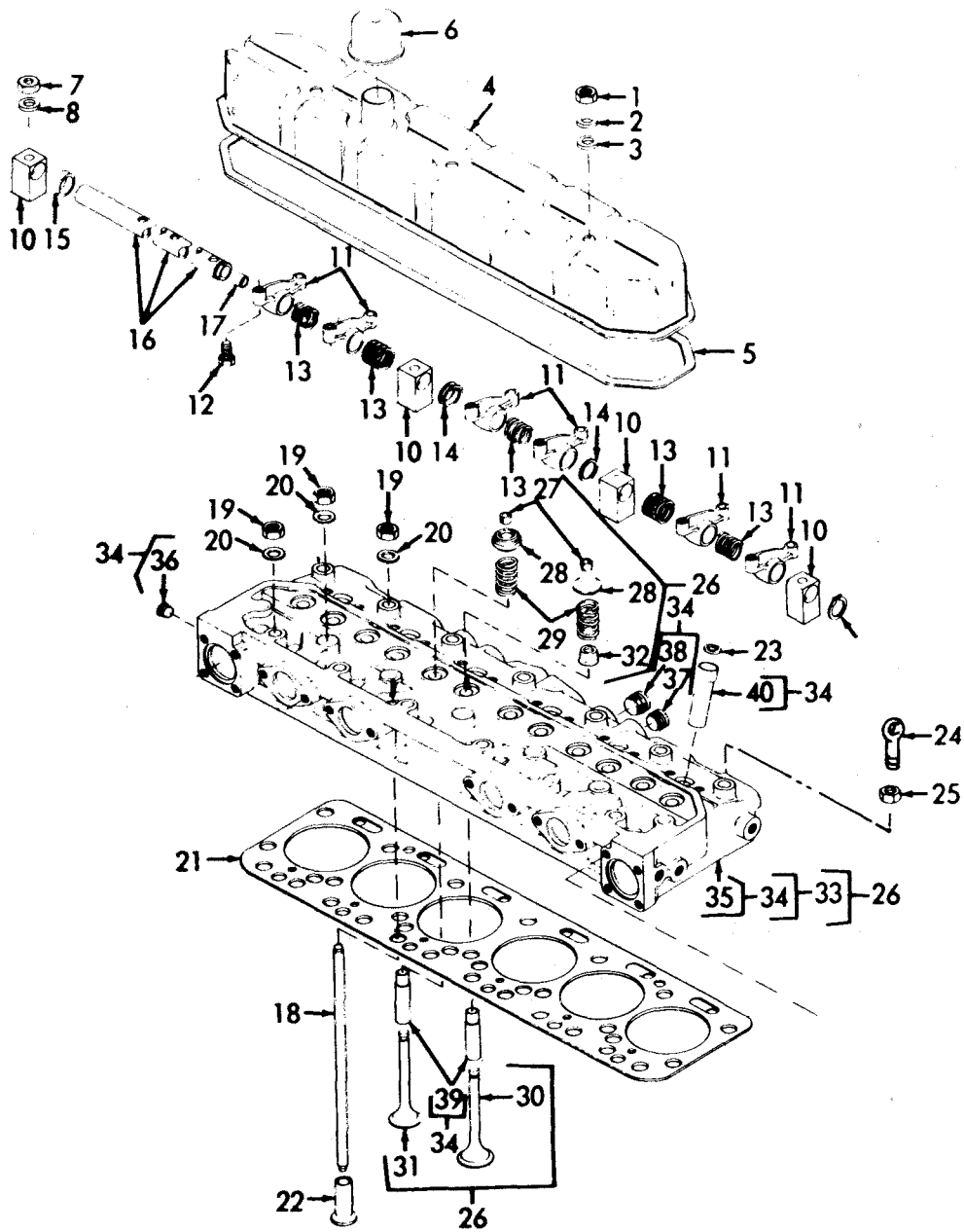


Figure 12-4. Cylinder Head and Valve Mechanism.

## LEGEND FOR FIGURE 12-4:

ITEM	NSN	P/N	FSCM	QTY
1. Nut, Self-Locking	5310-00-925-9642	40-0001720A	28265	3
2. Washer, Flat	5310-00-050-2241	4023A	28265	3
3. Washer, Flat	5310-00-987-6365	206432A	28265	3
4. Cover, Rocker Arm		285203E	28265	1
5. Gasket	5330-00-678-3823	285213C	28265	1
6. Cap, Breather	4940-01-096-8591	206963B	28265	1
7. Nut, Plain	5310-01-056-1107	1500-02325	28265	6
8. Washer, Flat	5310-00-703-8213	203077A	28265	6
9. Ring, Snap		203480A	28265	2
10. Support, Shaft		40-3005201C	28265	7
11. Arm Rocker Special	2815-00-961-1660	288077BS	28265	12
12. Screw,	5305-00-630-4811	40-0017301B	28265	12
13. Spring, Shaft		255080A	28265	6
14. Spacer		40-0003820A	28265	22
15. Spacer, Center		40-0003821A	28265	2
16. Shaft		40-3005101C	28265	2
17. Plug, Cup		13132A	28265	2
18. Rod, Push	2815-00-678-6083	2550138	28265	12
19. Nut, Plain	5310-01-028-9989	1500-02326	28265	14
20. Washer	5310-00-483-2266	203078A	28265	14
21. Gasket	5330-00-133-0811	287218D	28265	1
22. Valve, Tappet	2815-00-678-6082	255012A	28265	12
23. Gasket	5330-00-167-9009	206752A	28265	2
24. Eye, Lifting		206425A	28265	2
25. Nut, Plain, Hex	5310-00-010-3030	1124A	28265	2
26. Cylinder Head w/ Valves		40-3020280A	28265	1
27. Lock, Valve	2815-00-270-3435	77019A	28265	24
28. Retainer		255023A	28265	12
29. Spring, Helical	5360-00-871-6756	288021A	28265	12
30. Valve, Poppet	2815-00-903-3566	291010B	28265	6
31. Valve, Poppet	2815-00-928-8867	293011B	28265	6
32. Seal, Valve	2815-00-961-4573	288020A	28265	6
33. Cylinder Head Assy.		40-3020279A	28265	1
34. Cylinder Head Subassy.		40-3020370A	28265	1
35. Cylinder Head		293200E	28265	1
36. Plug, Pipe		206515E	28265	1
37. Plug, Pipe	4730-00-801-8186	1075A	28265	2
38. Plug, Pipe	4730-00-364-1171	4746A	28265	2
39. Guide, Valve	2815-00-961-1674	256019B	28265	12
40. Sleeve		293517A	28265	6

**NOTE**

Record position and quantity of spacers (14 and 15) to facilitate assembly.

- (2) Remove adjustment screws (12).
- (3) Separate shafts (10) and bushings (15) from center mounting block (20).
- (4) Do not remove plugs.
- (5) Using a valve spring depressor, depress valve springs and remove locks (27).
- (6) Release valve springs and remove spring seats (28), valve springs (29), exhaust valves (31), and intake valves (30).
- (7) Remove and discard seals (32).
- (8) Do not remove valve guides (39), plugs (36, 37, and 38), studs, fuel injector sleeves (40), and seal unless inspection reveals damage.
- (9) Remove side plates from cylinder block (3).
- (10) Remove valve tappets (22).

c. Cleaning, Inspection, and Repair.

- (1) Clean all parts in cleaning solvent and dry thoroughly with filtered compressed air.
- (2) Scrape carbon deposits from valves and cylinder head.
- (3) Visually inspect rocker arms for cracks, corrosion, and excessive wear. Check that oil holes are open.
- (4) Inspect rocker arm shafts for cracks, deep wear patterns, nicks, and burrs. Remove minor nicks and burrs with oil soaked crocus cloth. Clean polished shaft in dry cleaning solvent to remove abrasive particles.
- (5) Inspect blocks for cracks, nicks, burrs, and excessive wear. Remove nicks and burrs from outer surfaces with fine abrasive paper or stone.
- (6) Inspect springs for cracks, breaks, chaffing and distortion.
- (7) Inspect push rods for cracks, bends, excessive wear, nicks and scratches. Polish push rods with crocus cloth to remove minor defects.

- (8) Inspect valve guides for excessive wear. Bore diameter of exhaust valve guide shall be 0.3750 to 0.3790 inch. Bore diameter of intake valve guide shall be 0.3740 to 0.3780 inch.
- (9) Replace worn valve guides as follows:
  - (a) Use a 5/8-inch drift with a 3/8-inch pilot and drive out valve guides.
  - (b) Drive replacement valve guides to depth of 1.3700 to 1.3800 inches below cylinder head deck.
  - (c) Ream bore diameter of intake valve guides to 0.3740 to 0.3750 inch.
  - (d) Ream bore diameter of exhaust valve guides to 0.3750 to 0.3760 inch.
- (10) Inspect valve springs for cracks, breaks, and distortion. Using a spring tester, compress valve spring to a length of 1.4920 inches. Test load shall be 72 to 82 pounds. Compress spring to a length of 1.0820 inches. Test load shall be 80 to 86 pounds.
- (11) Inspect cylinder head for cracks, breaks, and broken studs. Remove broken studs by center punching, drilling, and using an easy out.
- (12) Check cylinder head for warpage using a straight edge and feeler gauge. Check lengthwise and between each cylinder crosswise. Warpage shall not exceed 0.003 inch laterally and 0.005 inch longitudinally. Cylinder head may be milled to remove minor warpage.
- (13) Perform magnetic particle inspection in accordance with established procedures.
- (14) Inspect valve seats of cylinder head. If they are pitted or if new valve guides were installed, the valve seats must be refinished, using a tool with a 3/8-inch pilot. Both intake and exhaust valve seats should be refinished on an angle of 30 degrees for intake valves and 45 degrees for exhaust valves.

#### NOTE

Use a vibrating angle grinder type tool. The large diameter and surface area of the valve seats makes obtaining a proper finish with a reamer type tool extremely difficult.

- (15) Inspect valve for bent or broken stems, cracks, and pitting of sealing surface. Using a micrometer, check valve stem diameter to determine wear. Stem diameter of intake valves shall be

0.3725 to 0.3735 inch. Stem diameter of exhaust valves shall be 0.3740 to 0.3750 inch.

(16) Check all threads for crossing, stripping, and peening. Repair minor thread damage with a thread chaser.

(17) Repair slightly damaged valves as follows:

(a) Polish stems with crocus cloth to remove minor nicks and scratches.

(b) Reface slightly pitted valves on a valve grinding machine. See table 1-1 for valve seat width.

(18) If valves and valve seats have been refinished or if contact surfaces are only slightly pitted, lap each valve into its seat as follows:

(a) Install a light coil spring with enough tension to hold valve off its seat.

(b) Lubricate valve stem and guide.

(c) Apply a thin coating of coarse grinding compound to the valve face.

(d) Insert valve into valve guide and attach a hand grinding tool .

**CAUTION**

Avoid continuous round and round motion which could cut grooves in valve face and seat.

(e) Rotate valve back and forth while applying firm pressure on the grinding tool.

(f) Release pressure on grinding tool, allowing coil spring to lift valve from its seat.

(g) Rotate valve 15° to 20° and repeat the grinding process.

(h) Periodically clean valve and seat to check progress.

(i) Replenish grinding compound and continue grinding until the valve seat and valve surfaces are in contact.

(j) Remove valve. Clean valve and valve seat to remove all traces of coarse grinding compound.

(k) Apply a thin coating of fine grinding compound to face of valve.

- (l) Install valve into cylinder head and repeat grinding process until a bright, silver-like band of uniform width appears on both valve and seat.
- (m) Remove valve. Clean valve and valve seat to remove all traces of grinding compound. Dry valve and valve seat thoroughly.
- (n) Make ten or twelve pencil marks, equally spaced, across valve seat.
- (o) Install valve, press firmly, and rotate approximately one quarter of a turn.
- (p) Remove valve and observe pencil marks. If marks are rubbed out, valve is seating properly. If all pencil marks are not rubbed out, repeat grinding process.

**CAUTION**

Mark each valve to insure that it will be installed in the seat into which it was ground.

- (q) Repeat grinding process for each valve.

d. Assembly.

- (1) Lubricate stem of intake valves (30) and exhaust valves (31) and insert into valve guides (39).
- (2) Install seals (32), valve springs (29), spring seats (28) and locks (27).

**NOTE**

Seals are installed on intake valves only.

- (3) Assemble rocker arm assembly as follows:
  - (a) Install adjusting screws (12) into rocker arms (11).
  - (b) Assemble springs (13), rocker arms (11), spacers (14 and 15) and mounting blocks (10) onto rocker arm shaft (16). Make sure that mounting blocks and spacers are correctly installed (fig. 12-5) and that oil holes in rocker arm shaft are correctly positioned (fig. 12-6).
  - (c) Install retaining rings (9, figure 12-4).



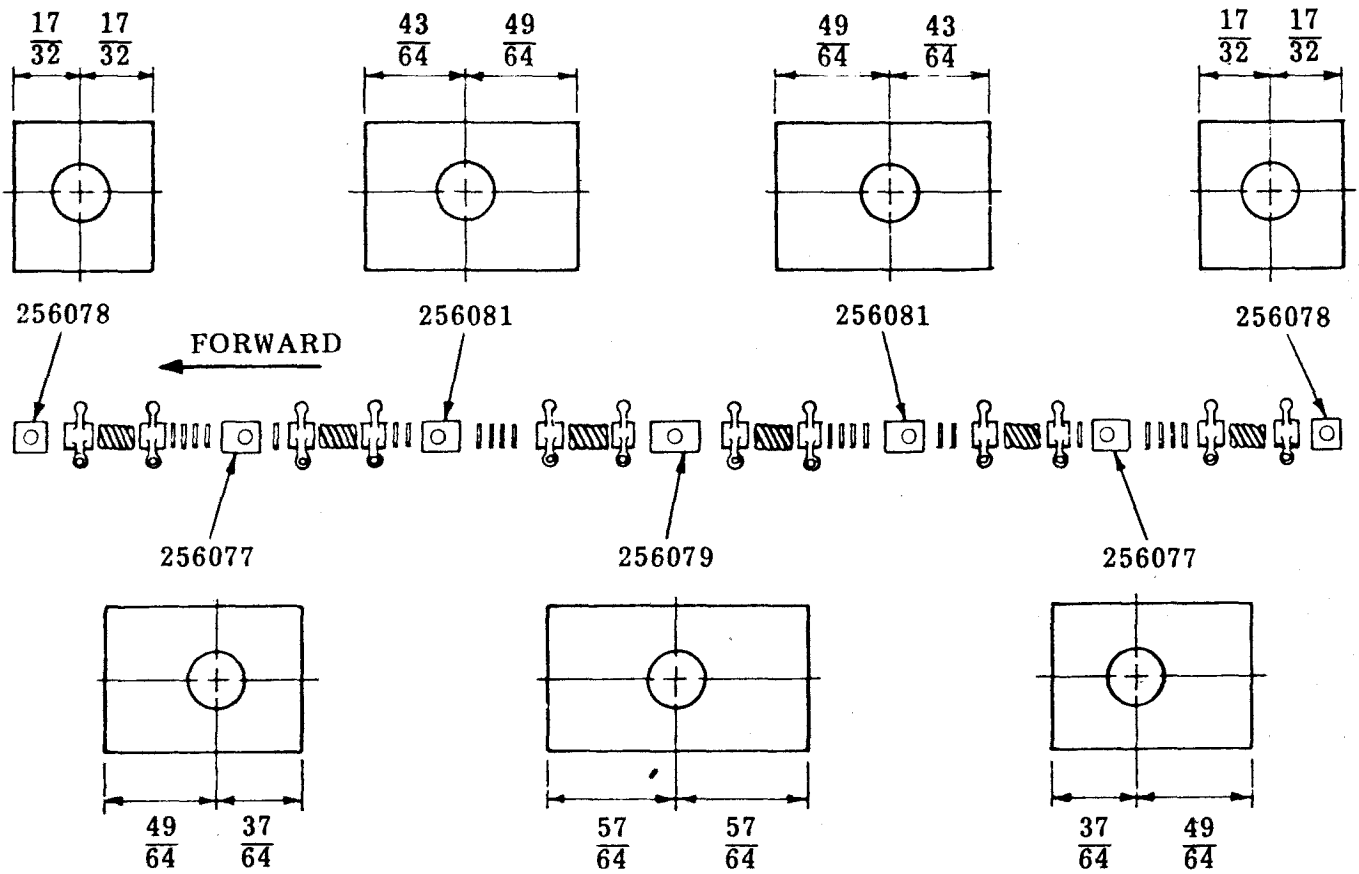


Figure 12-5. Rocker Arm Mounting Blocks Installation.

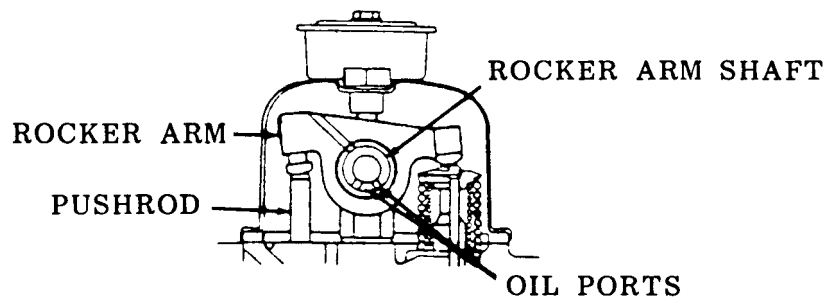


Figure 12-6. Rocker Arm Shaft Positioning.

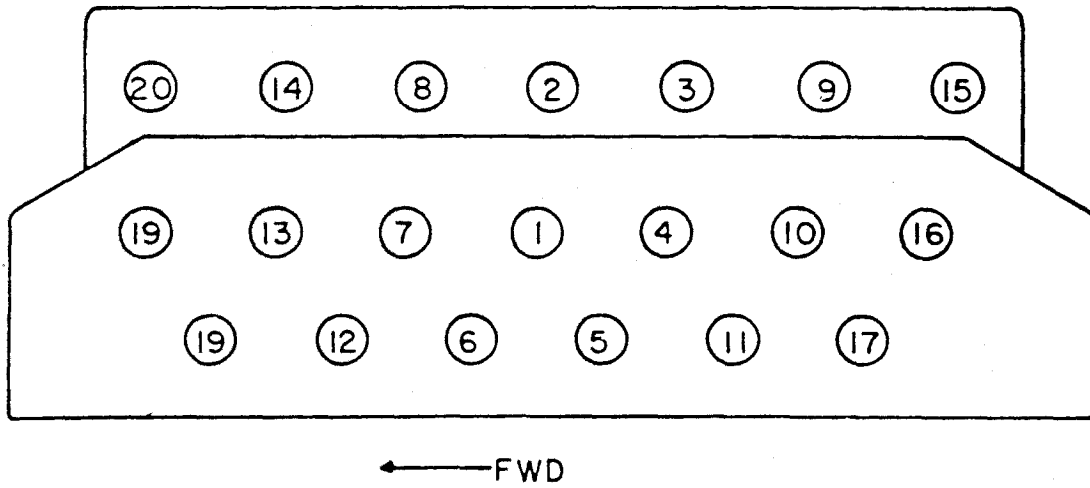


Figure 12-7. Cylinder Head Nut Tightening Sequence.

e. Installation.

- (1) Install cylinder head and rocker arm assembly in reverse order of removal procedures.
- (2) Torque nuts to 75 lb-ft following the sequence of figure 12-7.
- (3) Repeat the sequence, torque each nut 125 lb-ft.
- (4) Again repeat the sequence, torque each nut as specified in paragraph 1-7b.

**NOTE**

Nuts must be retorqued after 1 hour operation.

- (5) Refer to f and adjust the valve tappet clearance.

**NOTE**

After engine warm-up, readjust valves to a "hot" setting of 0.012 inch.

f. Valve Adjustment.

- (1) Operate the engine until the coolant temperature gauge indicates normal operating temperature.
- (2) Remove the valve cover.
- (3) Bar the engine over by hand until both the intake and exhaust valves on No. 1 cylinder are completely closed.
- (4) Using a feeler gauge, check clearance between the valve stem and the rocker arm on both intake and exhaust valves (fig. 12-8). Clearance should be 0.007 to 0.012 inch.
- (5) If the clearance is not specified, use a suitable wrench to rotate adjusting screw until proper clearance is obtained.
- (6) Check and, if necessary, adjust the clearance of the valves on the remaining cylinders as outlined in paragraph (3) , (4), and (5) above, following the firing order of 1, 5, 3, 6, 2, and 4.
- (7) When all valves are properly adjusted install the valve cover.

**12-5. CAMSHAFT.**

a. Removal.

- (1) Remove oil pan (para. 10-3).

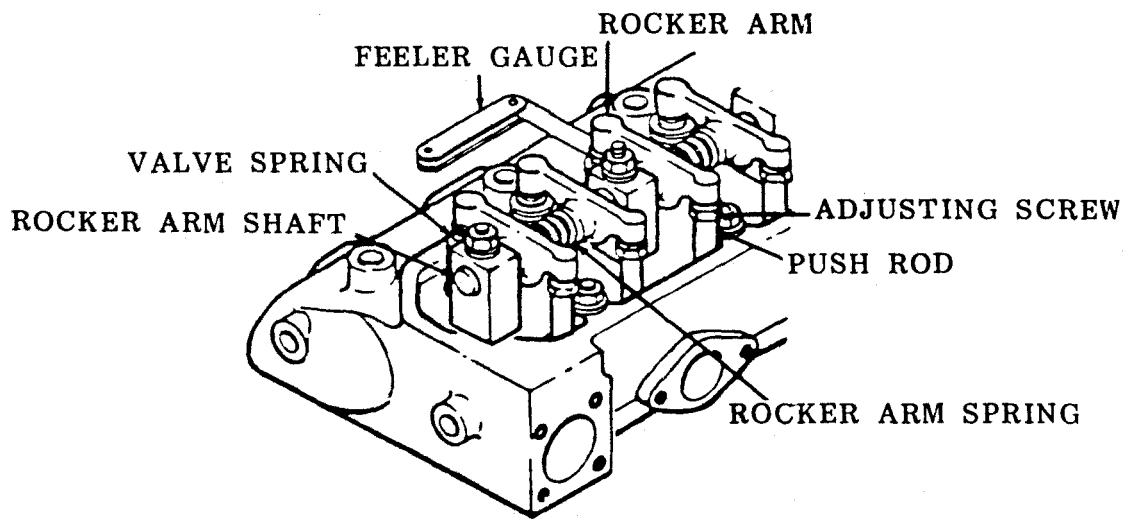
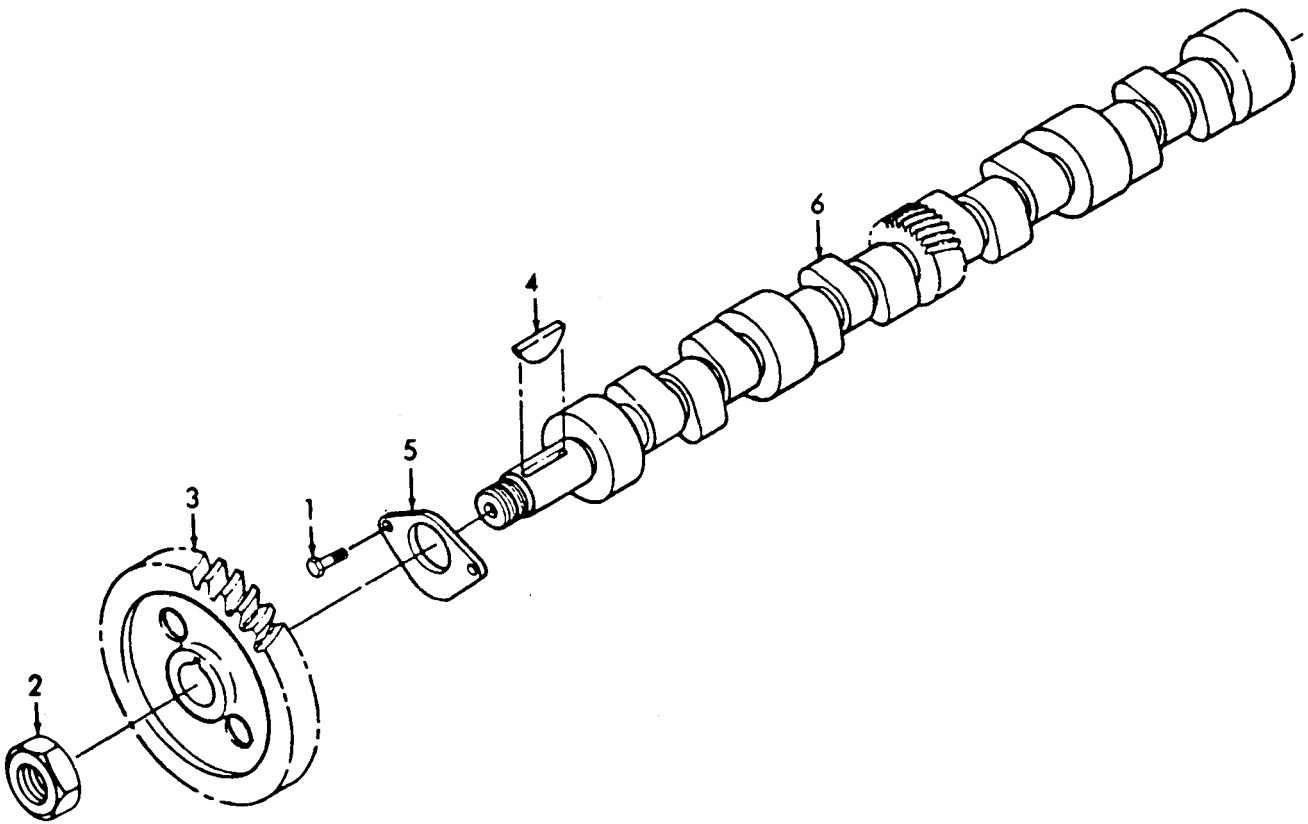


Figure 12-8. Valve Tappet Clearance Adjustment.



LEGEND FOR FIGURE 12-9:

ITEM	NSN	P/N	FSCM	QTY
1. Bolt Assembled	5306-00-786-4021	201991A	28265	2
2. Nut		25510A	28265	1
3. Gear	3020-00-614-6480	256070C	28265	1
4. Key		4265A	28265	1
5. Plate		255072A	28265	1
6. Camshaft	2815-00-133-0815	287060B	28265	1

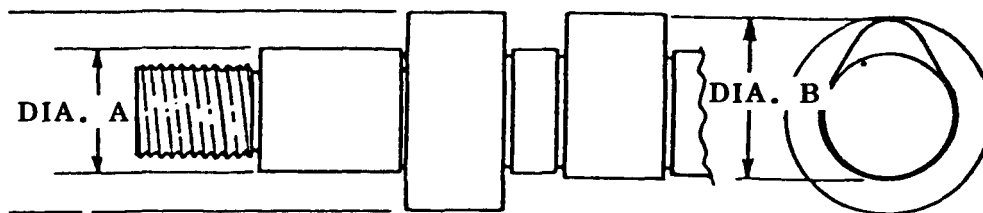
Figure 12-9. Camshaft, Exploded View.

- (2) Remove oil pump assembly (para. 10-4).
- (3) Remove timing gear cover (para. 12-3).
- (4) Remove rocker arm assembly and push rods (para. 12-4).
- (5) Rotate engine crankshaft until screws (1, figure 12-9) are visible through holes in camshaft drive gear.
- (6) Remove the fuel filter assemblies.

#### NOTE

Rotate crankshaft as necessary to lift valve tappets. Use tapered wooden dowels or magnets to hold tappets in topmost position.

- (7) Remove screws (1) and lockwashers (2) to remove camshaft.
  - (8) Remove valve tappets.
- b. Disassembly.
- (1) Remove nut (3, figure 12-9) and support drive gear (4) on arbor press.
  - (2) Press shaft (5) out of gear and remove key (6) and thrust plate (7).
- c. Cleaning, Inspection, and Repair.
- (1) Clean all parts in cleaning solvent and dry thoroughly with filtered compressed air.
  - (2) Visually inspect drive gear for cracks and chipped, broken, or worn teeth.
  - (3) Check thrust plate for cracks, breaks, and excessive wear.
  - (4) Use a micrometer to determine camshaft bearing journal diameter and lobe diameter in accordance with figure 12-10.
  - (5) Inspect camshaft lobes and bearing journals for wear, scoring, and scratching. Polish minor nicks, scores, and scratches with crocus cloth. Clean to remove abrasive residue.
  - (6) Check camshaft bearing runout as follows:
    - (a) Place camshaft in a set of vee blocks.
    - (b) Position a dial indicator so that the foot rides on one of the bearing journals.



**DIAMETER A: BEARING JOURNAL  
2.0530 TO 2.0540 INCH.**

**DIAMETER B: LOBE DIAMETER-BASE-TO-TIP.  
1.7200 TO 1.7250**

Figure 12-10. Dimensional Inspection of Camshaft.



- (c) Set indicator pointer to "zero" position.
  - (d) Slowly rotate camshaft one complete revolution while observing dial indicator.
  - (e) Runout shall not exceed 0.0040 inch total indicator reading.
  - (f) Repeat the check for each bearing journal.
- (7) If runout of any bearing exceeds limit specified total (step 6 (e) above), replace camshaft and bearings.
  - (8) Perform magnetic particle inspection on camshaft and drive gear in accordance with established procedures.
  - (9) Check all threads for crossing, stripping, and peening. Repair minor thread damage using a thread chaser.
  - (10) Measure and record diameter of camshaft bearings in cylinder block. Subtract camshaft bearing journals dimensions from the corresponding bearing inner diameter. The difference shall not be less than 0.0015 inch or greater than 0.0035 inch.
  - (11) If dimension obtained in step (8) indicates excessive wear, replace camshaft bearings as follows:
    - (a) Using a suitable press, remove camshaft bearings from cylinder block.

**CAUTION**

Make sure that the replacement bearings are installed so that oil holes match with oil ports in cylinder block.

- (b) Press replacement bearings into cylinder block.

d. Assembly.

- (1) Assemble camshaft in reverse order of removal procedures.
- (2) Torque nut (3, figure 12-9) to 130 lb-ft.

e. Installation.

**NOTE**

Valve tappets must be in the UP position to install camshaft.

**CAUTION**

Make sure that timing mark on camshaft drive gear mates with timing mark on crankshaft gear.

- (1) Install camshaft in reverse order of removal procedures,
- (2) Check camshaft end thrust as follows:
  - (a) Attach a dial indicator to the cylinder block and position so that the foot contacts the end of the camshaft.
  - (b) Press camshaft as far into the cylinder block as it will go.
  - (c) Set dial indicator to "zero" position.
  - (d) Move camshaft as far forward as it will go.
  - (e) Check indicator reading. Reading shall not exceed 0.0120.
  - (f) If reading exceeds specified limit, remove camshaft and replace thrust plate.
- (3) Check backlash between camshaft drive gear and crankshaft gear. Backlash shall be 0.0010 to 0.0030. If backlash is not within specified limits, both camshaft drive gear and crankshaft gear must be replaced.

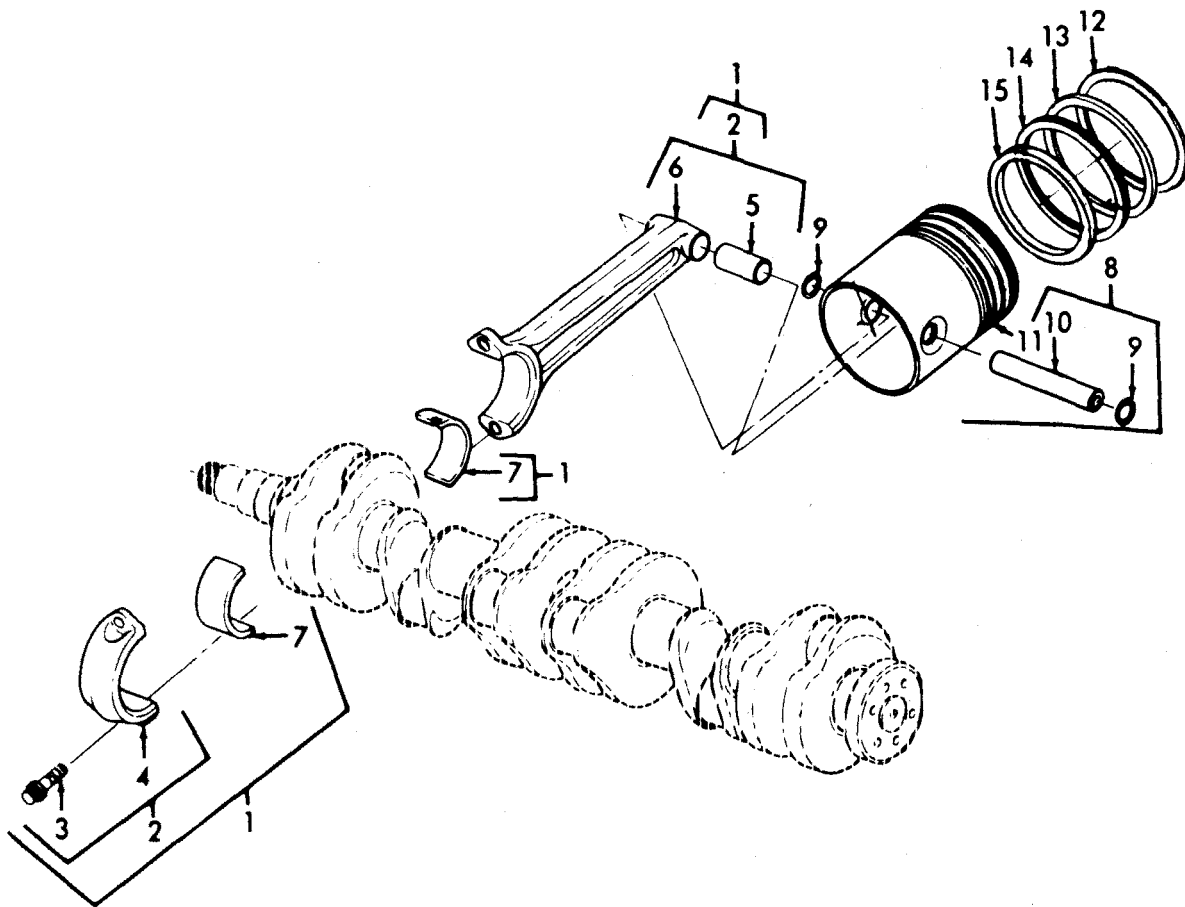
**12-6. CRANKSHAFT, CONNECTING RODS, AND PISTONS.**

a. Removal.

- (1) Remove oil pump assembly (para. 10-4).
- (2) Remove flywheel and flywheel housing (para. 12-2).
- (3) Remove cylinder head and rocker arm assembly (para. 12-4).
- (4) Using a ridge cutter, remove the ridge from the top of each cylinder.
- (5) Remove screws (3, figure 12-11) and connecting rod bearing caps (4) and lower half of connecting rod bearing (7).
- (6) Using a wooden dowel, push pistons and connecting rods out top of cylinder block.

**NOTE**

Remove crankshaft to simplify removal if necessary.



LEGEND FOR FIGURE 12-11:

ITEM	NSN	P/N	FSCM	QTY
1. Rod Assy.		288290AS	28265	6
2. Rod Assy.		288291AS	28265	6
3. Bolt, Rod Cap		40-3093301A	28265	12
4. Cap, Rod		288198B	28265	6
5. Bushing, Sleeve	3210-00-917-1858	288199A	28265	6
6. Rod, Connecting		2881970	28265	6
7. Bearing Sleeve	3120-00-909-6148	288092A	28265	12
8. Piston Assy.	2815-00-904-7478	291160AS	28265	6
9. Retainer, Piston	5365-00-230-3493	40-0000706A	28265	12
10. Pin, Piston	2815-00-898-4887	286116A	28265	6
11. Piston, Engine		291159C	28265	6
12. Ring, Compression		77112B	28265	6
13. Ring, Compression		291161B	28265	6
14. Ring, Compression		291162B	28265	6
15. Ring, Oil		291163B	28265	6
16. Ring Set (Contains #12, 13, 14, 15)	2815-00-133-0816	291168AS	28265	6

Figure 12-11. Piston and Connecting Rods.

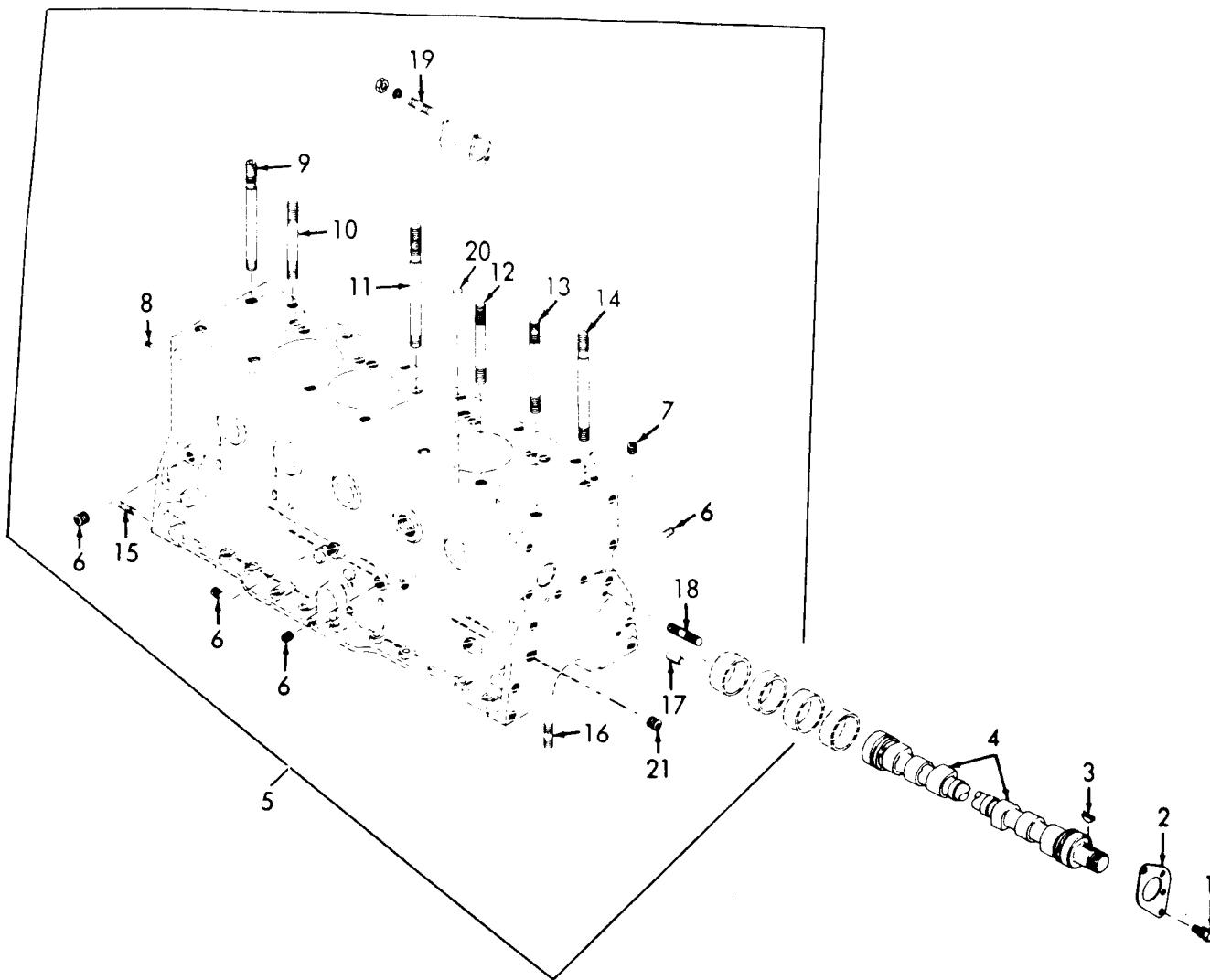


Figure 12-12. Cylinder Block Assembly (Sheet 1 of 2).

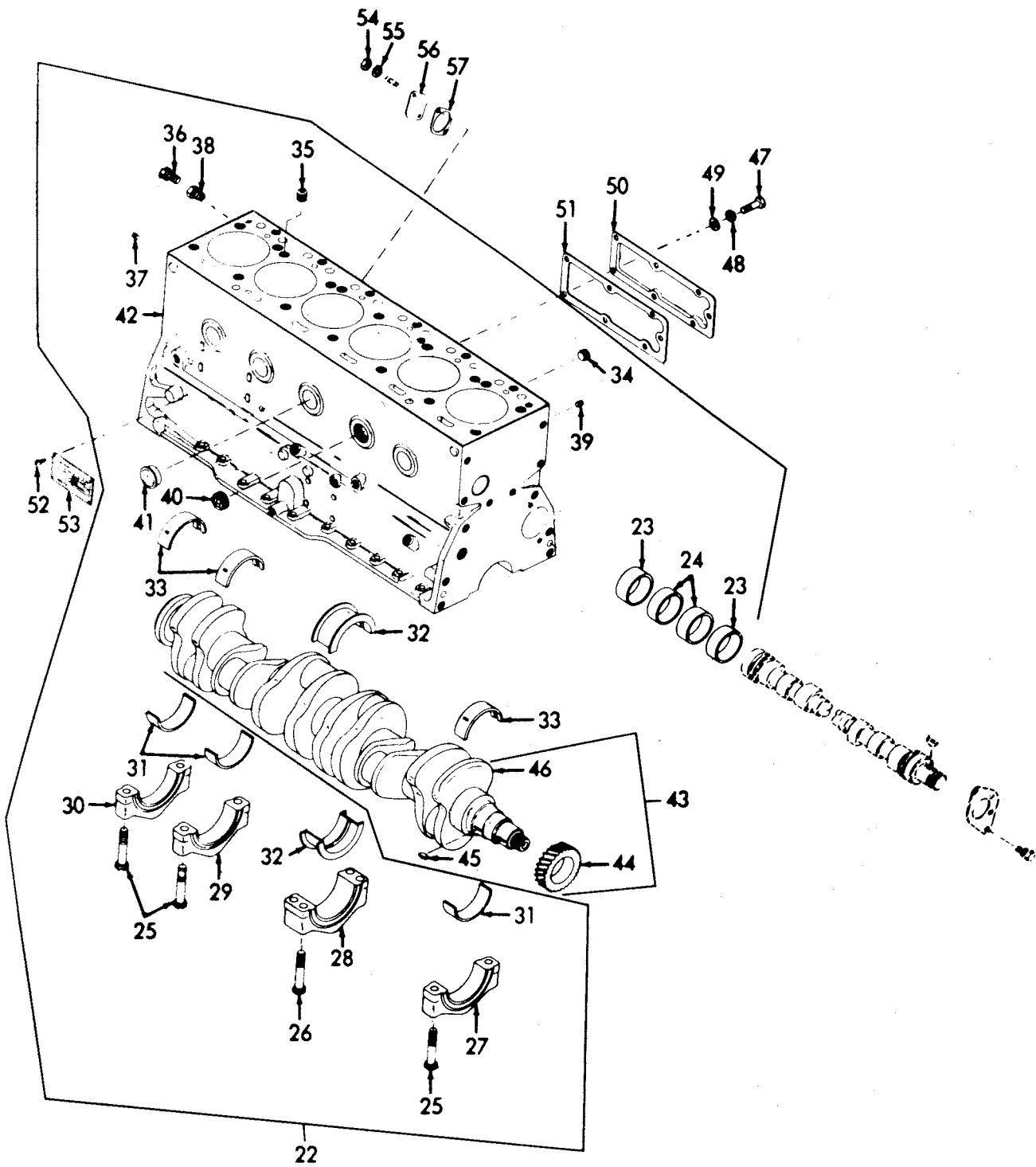


Figure 12-12. Cylinder Block Assembly (Sheet 2 of 2).

## LEGEND FOR FIGURE 12-12:

ITEM	NSN	P/N	FSCM	QTY
1. Bolt Assembled	5306-00-786-4021	201991A	28265	2
2. Plate, Camshaft		255072A	28265	1
3. Key, Woodruff	5315-00-021-8211	4265A	28265	1
4. Camshaft	2815-00-133-0815	287060B	28265	1
5. Cylinder, Block		40-3001772B	28265	1
6. Plug, Pipe	4730-00-278-3397	59A	28265	4
7. Plug, Pipe		48-6	76894	2
8. Setscrew		205317A	28265	1
9. Stud, Plain	5307-00-616-7216	40-0001619B	28265	1
10. Stud, Plain	5307-00-677-8889	13814B	28265	6
11. Stud, Stepped	5307-00-616-7206	40-0001618B	28265	3
12. Stud, Recessed	5307-00-616-7203	40-0001617B	28265	3
13. Stud, Plain	5307-00-623-1802	203986B	28265	5
14. Stud, Plain	5307-00-630-4836	204591B	28265	2
15. Stud, Plain	5307-00-464-7215	14907A	28265	2
16. Stud, Plain	5307-00-616-6016	11833A	28265	4
17. Dowel		11557A	28265	4
18. Stud	5307-00-429-0140	12293A	28265	1
19. Stud, Plain	5307-00-261-0408	204601A	28265	2
20. Dowel		204601A	28265	2
21. Plug, Pipe		40-0000104A	28265	1
22. Cylinder Block Sub-Assy.		40-3001771A	28265	1
23. Bearing, Sleeve	3120-00-678-6087	255073B	28265	2
24. Bearing, Sleeve	3120-00-973-5966	40065A	28265	2
25. Screw, Machine	5305-00-987-1132	288105A	28265	12
26. Bolt, Self-Locking	5306-00-843-8563	205351A	28265	4
27. Cap, Main Brg.		288100C	28265	1
28. Cap, Main Brg.		288101C	28265	4
29. Cap, Main Brg.		285123C	28265	1
30. Cap, Main Brg.		288102C	28265	1
31. Bearing, Half		285129A	28265	6
32. Bearing, Half		285111A	28265	2
33. Bearing, Half		288104A	28265	6
34. Plug, Pipe	4730-00-364-1171	4746A	28265	4
35. Plug, Pipe		205377A	28265	4
36. Bushing, Pipe	4730-00-193-0883	203359A	28265	2
37. Plug, Pipe	4730-00-834-6187	MS51884-7H	96906	1
38. Bushing, Reducing	4730-00-277-1840	11813-A	28265	2
39. Plug, Pipe	4730-00-801-8186	1075A	28265	1
40. Plug, Pipe	4730-00-010-3876	7165A	28265	1
41. Plug, Cup		11683A	28265	3
42. Cylinder, Block		40-3001704J	28265	1
43. Crank and Gear	2815-00-133-4828	288026AS	28265	1
44. Gear, Crankshaft		1550288	28265	1
45. Key, Woodruff		MS05756-35	96906	1
46. Crankshaft		288025E	28265	1
47. Screw, Cap	5305-00-115-9526	MS90725-58	96906	10

## LEGEND FOR FIGURE 12-12:

ITEM	NSN	P/N	FSCM	QTY
48. Washer, Lock	5310-00-637-9541	MS35338-46	96906	12
49. Washer, Flat	5310-00-684-3463	MS51092-1	96906	2
50. Cover, Plate		2860138	28265	2
51. Gasket	5330-00-435-6130	2860148	28265	4
52. Screw, Drive	5305-00-363-9695	2189A	28265	4
53. Plate, Instruction		2045098	28265	1
54. Nut, Plain	5310-00-268-6093	28A	28265	4
55. Washer, Lock	5310-00-407-9566	MS35338-45	96906	4
56. Cover, Plate		255761A	28265	1
57. Gasket	5330-00-842-0363	255772A	28265	1
58. Bearing Set (Contains #31, 32, 33)	3120-00-842-0630	288106AS	28265	1

- (7) Remove upper half of connecting rod bearing insert.

**CAUTION**

Keep connecting rod bearing caps with the connecting rod from which they were removed.

- (8) Remove screws (25, figure 12-12) to remove main bearing caps (27, 28, and 29) and lower half of main bearing inserts (31).
- (9) Remove screws (26) to remove main bearing cap (28) and lower half of center main bearing insert (32).
- (10) Lift crankshaft (43) from cylinder block and remove upper half of main bearing inserts.

**CAUTION**

Conspicuously mark each main bearing cap as to position to aid at assembly.

b. Disassembly.

- (1) Do not remove crankshaft gear (44) and woodruff key (45) unless inspection reveals damage and replacement is necessary.
- (2) Remove retaining ring (9, figure 12-11) and piston pin (10) to remove piston assembly (11) from connecting rod (6).
- (3) Do not remove bushing (5) unless inspection reveals damage and replacement is necessary.
- (4) Remove compression rings (12 and 13), scraper rings (14) and oil control ring (15 ) from piston (11). Discard piston rings.

c. Cleaning, Inspection, and Repair.

- (1) Clean all parts in cleaning solvent and dry with filtered compressed air.
- (2) Clean all oil passages in crankshaft and connecting rods with a wire brush.

**CAUTION**

Use care to avoid damaging ring grooves in pistons.

- (3) Scrape carbon deposits from top and ring groove of piston.



- (4) Inspect crankshaft for cracks, nicks, and scratches on bearing journals or other damage. Remove minor nicks and scratches from bearing journals with crocus cloth. Clean to remove abrasive residue.
- (5) Perform magnetic particle inspection of crankshaft in accordance with established procedures.
- (6) Remove minor nicks, burrs, and scratches from crankshaft bearing journals by polishing with crocus cloth.

**CAUTION**

When regrinding crankshaft, it is imperative that the 5/32-inch radius from journal to cheek be maintained. Crankshaft breakage may result from improper grinding of this fillet.

- (7) If necessary, regrind crankshaft bearing journals to accept undersized bearings in accordance with table 12-1.
- (8) Inspect crankshaft gear for cracks and chipped, broken, or excessively worn teeth.
- (9) If replacement of crankshaft gear is necessary, proceed as follows :
  - (a) Support crankshaft gear in arbor press and press crankshaft and woodruff key from gear.
  - (b) Heat replacement gear in an oven at 450°F (232.2°C) for approximately one hour.
  - (c) Install woodruff key into crankshaft.

**CAUTION**

Wear asbestos gloves to avoid serious burns when handling heated gear.

- (d) Remove gear from oven and assemble onto crankshaft.
- (e) Using a driver with an inside diameter of 2-inches, quickly drive gear into position.
- (f) Allow crankshaft and gear to cool.
- (10) Inspect connecting rod for cracks, breaks, and excessively worn or damaged bushing.
- (11) Check piston pin for nicks, burrs, cracks, and excessive wear.

Table 12-1. Undersized Bearing Journals

Bearing size	Crankshaft journal diameter (IN. )	
	Main bearing	Connecting Rod
Standard	2.8734/2.8744	2.3730/2.3740
0.020 inch	2.8534/2.8544	2.3530/2.3540
0.040 inch	2.8334/2.8344	2.3330/2.3340
0.060 inch	2.8134/2.8144	2.3130/2.3140

- (12) Remove minor nicks and burrs from piston by polishing with crocus cloth. Clean to remove abrasive residue.
- (13) If necessary, replace both piston pin and bushing.

#### NOTE

If new piston pin and bushing are used, check connecting rod alignment on a standard aligning fixture.

- (14) Inspect piston for deep scores and scratches and other damage.
- (15) Insert each piston into its cylinder bore with a piece of 1/2 x 0.0050 feeler ribbon. A force of 5 to 8 pounds should be required to remove each ribbon. Replace all pistons if any are not within the required limits.

#### NOTE

Cylinder bores may be rebored to accept oversized pistons.

- (16) Fit each piston ring into place in its cylinder bore and using a feeler gauge, measure gap dimension. Gap shall be 0.0100 to 0.0200 inch. If gap is under 0.0100 inch, file as follows:
  - (a) Hold a file in a vise.
  - (b) Grasp piston ring in both hands.
  - (c) Insert file into ring gap and move ring down the entire length of the file. Be sure to apply equal pressure on the ring.
- (17) Roll each ring all the way around its piston groove to check clearance. If clearance is insufficient, lap the sides of the ring on a piece of No. 000 grit emery cloth laid on the flat surface.

#### d. Assembly.

- (1) Using a piston ring expander install oil control ring (15, figure 12-11), scraper ring (14), and compression rings (12 and 13), onto pistons (24).

#### NOTE

If replacement piston rings have dots on the rings, the rings should be installed with the dots toward the piston head.

- (2) Apply a light coat of engine oil to the bushing (5), and connecting rod (6), and press the bushing into the connecting rod.
- (3) Fit piston assemblies (11), onto connecting rods (6), and insert piston pins (10). Install retaining rings (9).

e. Installation.

**NOTE**

Prior to installation of piston assemblies inspect cylinder block, camshaft and cylinder head prior to installation of the piston, connecting rods and crankshaft .

- (1) Install upper half of main bearing inserts (32 and 33, figure 12-12) into cylinder block.

**NOTE**

Some of the bearings partially cover oil holes.

- (2) Carefully place crankshaft (43) into position.
- (3) Place a short strip of plastic gauge on each main bearing journal.
- (4) Install lower half of main bearings, main bearing caps (27, 28, 29, and 30), and screws (25 and 26).
- (5) Tighten screws (25) to 100 lb-ft torque. Tighten screws (26) to 130 lb-ft torque.
- (6) Remove main bearing caps and lower half of main bearings. Check plastic gauge against standard to determine main bearing clearance. Clearance shall be 0.0009 to 0.0034 inch.
- (7) If clearance is not within specified limits, grind crankshaft and install with undersized bearings (para. c(7) above).
- (8) When bearing clearances have been established, install lower half of main bearings and main bearing caps (step (4) above).

**NOTE**

Apply a liberal coating of engine lubricating oil to inner surface of main bearings prior to installation.

- (9) Use a feeler gauge to check crankshaft end thrust clearance on center main bearing. End thrust clearance shall be 0.0050 to 0.0100 inch.
- (10) If end thrust clearance is not as specified, remove center main bearing and polish sides on a piece of crocus cloth. Clean to remove abrasive residue and apply a liberal coating of engine lubricating oil before installation.
- (11) Apply a liberal coating of engine lubricating oil to cylinder bores, pistons, piston rings and piston pins.

### NOTE

Proper position of the oil ring gap is with the gap aligned with either piston pin hole.

- (12) Position piston rings so that no two gaps are aligned.

### CAUTION

Use care to insure that connecting rod is properly aligned with crankshaft connecting rod bearing journal and that the precombustion chamber is away from the camshaft side of the engine.

- (13) With piston rings compressed, use a hammer handle or wooden dowel to force piston down into cylinder bore.
- (14) When entire piston is in cylinder bore, insert upper half of connecting rod bearing (7, figure 12-11) and pull connecting rod down to crankshaft.
- (15) Place a short strip of plastic gauge on crankshaft and install lower half of connecting rod bearing, connecting rod cap (4) and screws (3). Torque screws to 70 lb-ft.
- (16) Remove screws and connecting rod bearing cap to remove plastic gauge.
- (17) Check plastic gauge against standard to determine bearing clearance. Clearance shall be 0.0010 to 0.0030 inch.
- (18) When clearance is established, install lower bearing half, bearing cap and screws (step 16, above).
- (19) Install timing gear housing and assembly.
- (20) Install cylinder head and rocker arm assembly.
- (21) Install fly wheel and flywheel housing.

(22) Install oil pump assembly.

## 12-7. CYLINDER BLOCK ASSEMBLY.

- (1) Remove engine assembly (para. 5-2).
  - (2) Remove timing gears and cover (para. 12-3).
  - (3) Remove flywheel and flywheel housing (para. 12-2).
  - (4) Remove cylinder head and rocker arm assembly (para. 12-4).
  - (5) Remove camshaft and bearings (para. 12-5).
  - (6) Remove crankshaft, connecting rods, and pistons (para. 12-6).
  - (7) Remove plugs (6 and 7, figure 12-12).
  - (8) Do not remove oil filler neck and captive cap assembly or stud unless inspection reveals damage.
  - (9) Do not remove studs (17 and 18) or guide pin (21) unless inspection reveals damage.
  - (10) Do not remove studs (15) and guide pin (6) unless inspection reveals damage.
  - (11) Do not remove studs (9, 10, 11, 12, 13, and 14) or guide pin (20) unless inspection reveals damage.
  - (12) Remove screws (47), flat washers (48), and lockwashers (49) to remove cover plate (50) and gasket (51) from cylinder block (42).
  - (13) Do not remove plugs (6 or 7) from cylinder block (42) unless replacement is necessary.
- b. Cleaning, Inspection, and Repair.
- (1) Clean sludge and dirt deposits from cylinder block with dry cleaning solvent. If necessary, block can be steam cleaned.
  - (2) Clean all oil and water passages.
  - (3) Scrape carbon deposits from top of block.
  - (4) Remove gasket remains from all mating surfaces.
  - (5) Perform magnetic particle inspection of cylinder block in accordance with MIL-I-6868.
  - (6) Inspect cylinder bores for scores and scratches. Minor scratches and scores may be removed by honing. If necessary, cylinder bores may be rebored to accept up to 0.060 inch oversized pistons.

- (7) Check cylinder bores for excessive wear. Diameter shall be 3.7490 to 3.7510 inches.
  - (8) Inspect cylinder bores for out-of-roundness. Each cylinder shall not be out-of-round by more than 0.0005 inch.
  - (9) Check cylinder bore taper. Taper shall be 0.0005 inch maximum.
  - (10) Non conformity to dimension specified in steps (7) through (9) above requires that cylinders be bored to accept oversized pistons.
  - (11) Temporarily install main bearing caps and check main bearing bore diameter. Diameter shall be 3.0665 to 3.0670 inches.
  - (12) Check camshaft bearing bore diameter. Diameter shall be 2.1870 to 2.1880 inches.
  - (13) Visually inspect main bearing and camshaft bearing bore diameters for nicks and scratches. Remove nicks and scratches with oil-soaked abrasive paper.
  - (14) Check oil pump bore diameter. Diameter shall be 2.0000 to 2.0005 inches.
  - (15) Inspect oil pump bore for nicks and scratches. Remove minor nicks and scratches by polishing with crocus cloth.
  - (16) Inspect for broken or damaged studs. If any studs are broken too short to allow removal, center punch, drill and use an easy out.
  - (17) Inspect all gasket surfaces for nicks, burrs, and scratches. Remove nicks, burrs, and scratches with oil soaked abrasive paper.
  - (18) Use a straight edge and check the block lengthwise, across each end and between cylinder bores for warpage. Warpage shall not exceed 0.003 inch. Remove studs and guide pins and mill to a maximum of 0.005 inch off top of block to correct slight warpage. If cylinder block is warped sufficiently that milling would radically affect engine performance, replace block.
  - (19) Check all internal threads for crossing, stripping, and peening. Clean or repair minor thread damage. Repair extensively damaged threads by reaming, tapping and installing inserts.
- c. Assembly and Installation. Assemble and install cylinder block in reverse order of removal and disassembly instructions.

## 12-8. CLUTCH.

- a. Removal and Disassembly.

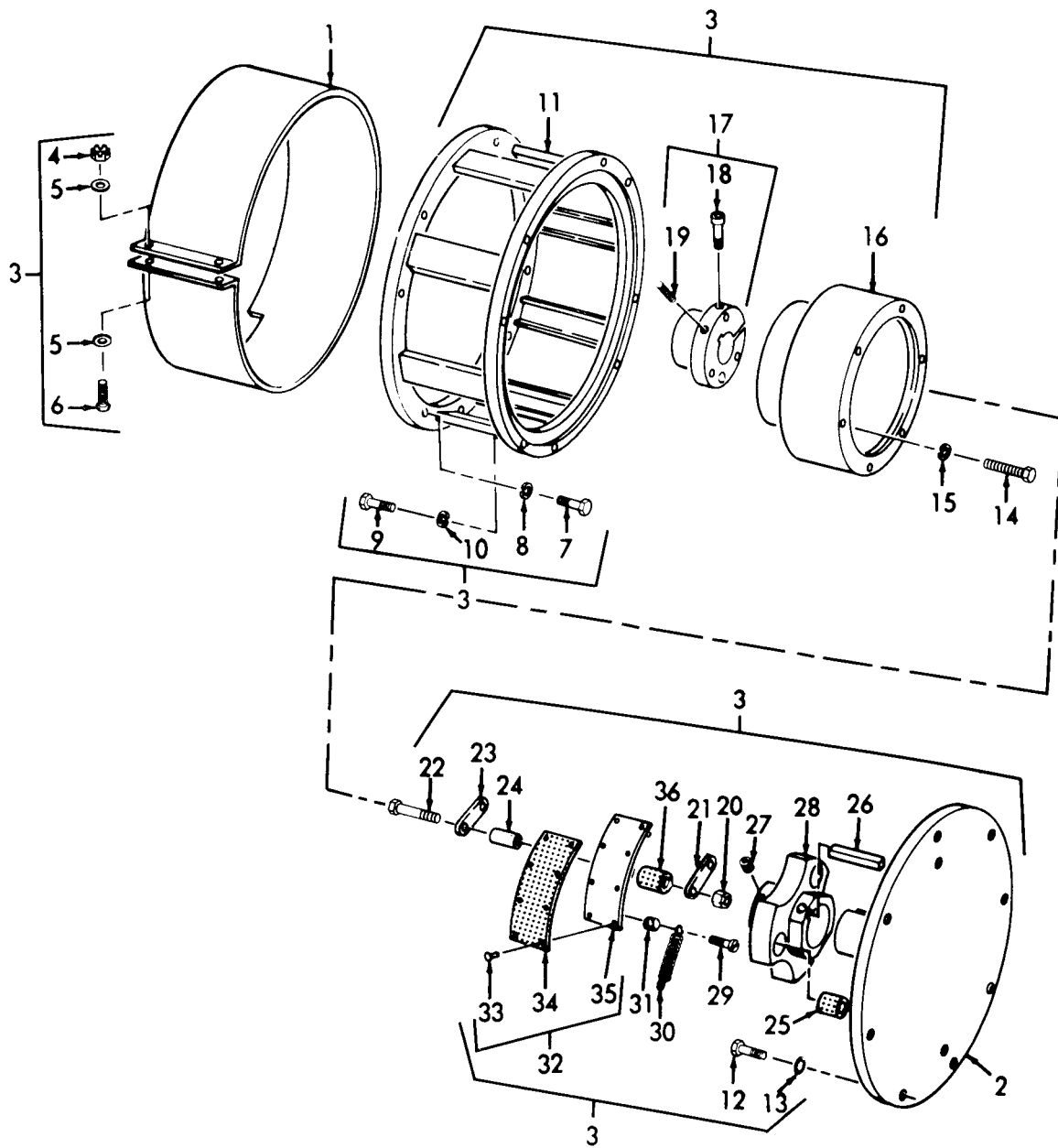


Figure 12-13. Clutch and Cover.



## LEGEND FOR FIGURE 12-13:

ITEM	NSN	P/N	FSCM	QTY
1. Resistor, Fixed	5905-01-099-0178	358744	28835	1
2. Plate, Drive		351564-1	28835	1
3. Clutch Friction	3010-01-080-5938	358087	28835	1
4. Nut, Plain	5310-00-834-8736	MS35691-2	96906	2
5. Washer, Flat	5310-00-809-4058	MS27183-10	96906	4
6. Screw, Machine	5305-00-988-1728	MS35206-287	96906	2
7. Screw, Cap	5305-00-725-2317	MS90728-64	96906	8
8. Washer, Lock	5310-00-637-9541	MS35338-46	96906	8
9. Screw, Cap	5305-00-725-2317	MS90728-44	96906	8
10. Washer, Lock	5310-00-637-9541	MS35338-46	96906	8
11. Spacer		358473	28835	1
12. Screw, Cap	5305-00-688-2111	MS90728-63	96906	8
13. Washer, Lock	5310-00-637-9541	MS35338-46	96906	8
14. Screw, Cap	5305-00-638-8920	MS90728-67	96906	3
15. Washer, Lock	5310-00-637-9541	MS35338-46	96906	3
16. Housing, Clutch		73-13-410	28718	1
17. Hub Assembly		73-904610	28718	1
18. Screw, Cap	5305-00-978-9381	MS16997-63	96906	1
19. Setscrew	5305-00-724-5886	MS51963-106	96906	1
20. Nut, Self-Locking	5310-00-959-1488	MS51922-21	96906	6
21. Link		73-32-410	28718	1
22. Bolt, Cap		73-48-410	28718	3
23. Link		73-32-410	28718	3
24. Spacer		73-37-410	28718	6
25. Bushing, Rubber		73-89-410	28718	3
Key, Woodruff		MS20066-543	96906	1
27. Setscrew	5305-00-724-6810	MS51963-101	96906	1
28. Hub, Clutch		73-23-410	28718	1
29. Screw, Machine	5305-00-969-6487	MS35266-59	96906	12
30. Spring		73-35-410G2	28718	6
31. Spacer, Clutch		73-22-410G	28718	12
32. Shoe Assy.		73H31A410G	28718	3
33. Rivet	5320-00-995-8256	MS16535-140	96906	24
34. Lining	2010-00-768-5381	73-64-410	28718	3
35. Shoe, Clutch		73H31-410G	28718	3
36. Bushing		73-89-410	28718	3

- (1) Remove the engine (para. 5-2).
- (2) Remove eight screws that secure the clutch drive plate to the flywheel, and remove the clutch drive plate.
- (3) Loosen setscrew and remove drive hub (17, figure 12-13) from clutch drive plate. Remove key.
- (4) Remove safety wire from twelve studs (29) and remove the six springs (30).
- (5) Remove six nuts (22) and remove the six bolts (20) and the six links (21 and 23).
- (6) Remove the six spacers (24) and remove the six rubber bushings (36).
- (7) Remove twenty-four rivets (33) that secure the three linings (34) to the three shoes (35).
- (8) Loosen setscrew in hub (19) and remove the clutch housing (3) with the hub (16) attached.
- (9) Remove the three screws (14) that secure the housing (3) to the hub (16). Two withdrawal holes with 3/8-16 thread 180° apart are located in the housing to push the hub (16) out of the housing.

b. Cleaning, Inspection, and Repair.

- (1) Clean parts with approved cleaning solvent and dry thoroughly.
- (2) Inspect for damaged or defective parts and replace defective or missing parts as necessary.
- (3) To replace the rubber bushings (36), use a circular plug slightly smaller than the outside diameter of the bushing outer sleeve, and preferably recessed, so that pressure is applied to the outer sleeve only and not to the inner sleeve.

c. Assembly and Installation.

- (1) Reassemble and install in reverse order.
- (2) Install links on the hub loosely with the serrated part of the links facing the hub. Refer to figure 12-14.
- (3) Install the links in the direction of rotation as shown in figure 12-14.
- (4) Press each shoe hard inward with the seating pads against the hub; torque hub and show bolts to 25 lb-ft.
- (5) Torque the three screws (14, figure 12-13) to 30 lb-ft.

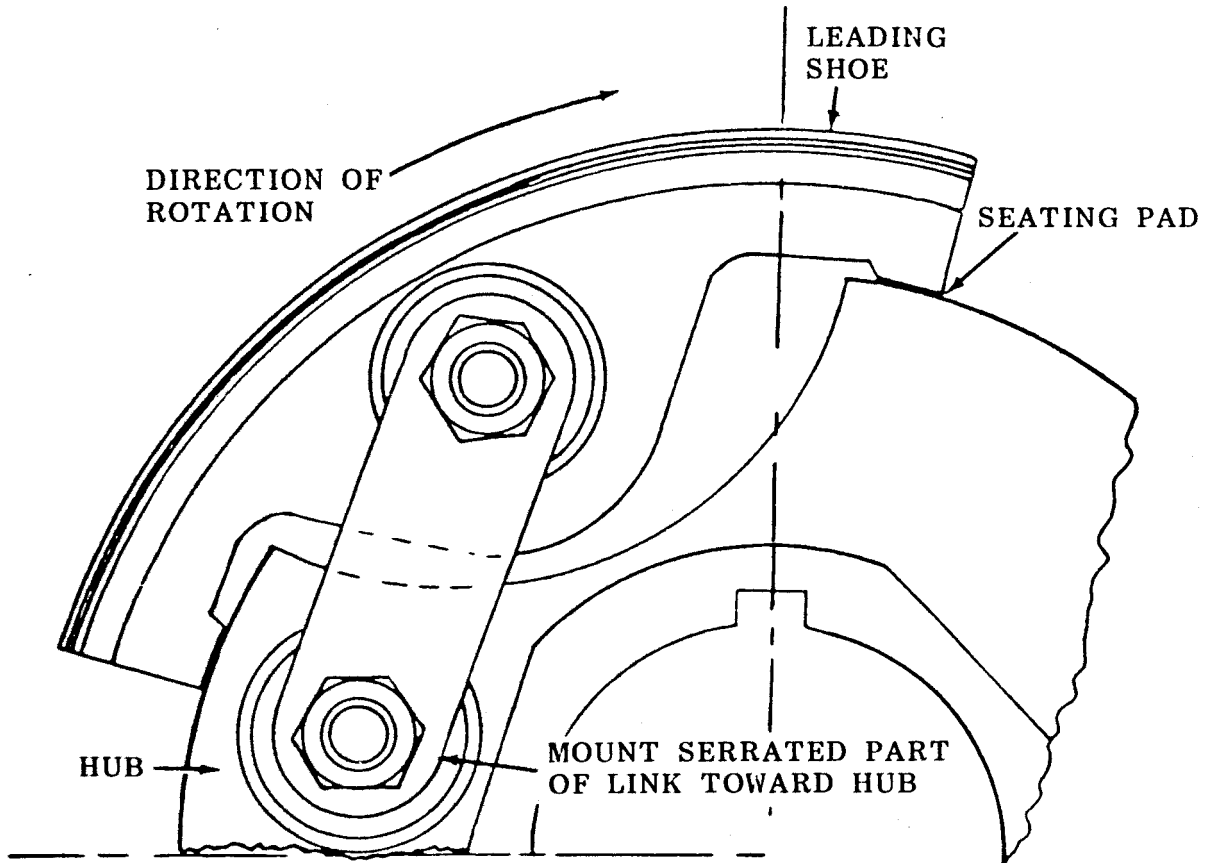


Figure 12-14. Clutch Assembly, Removal, Disassembly, Reassembly and Installation.



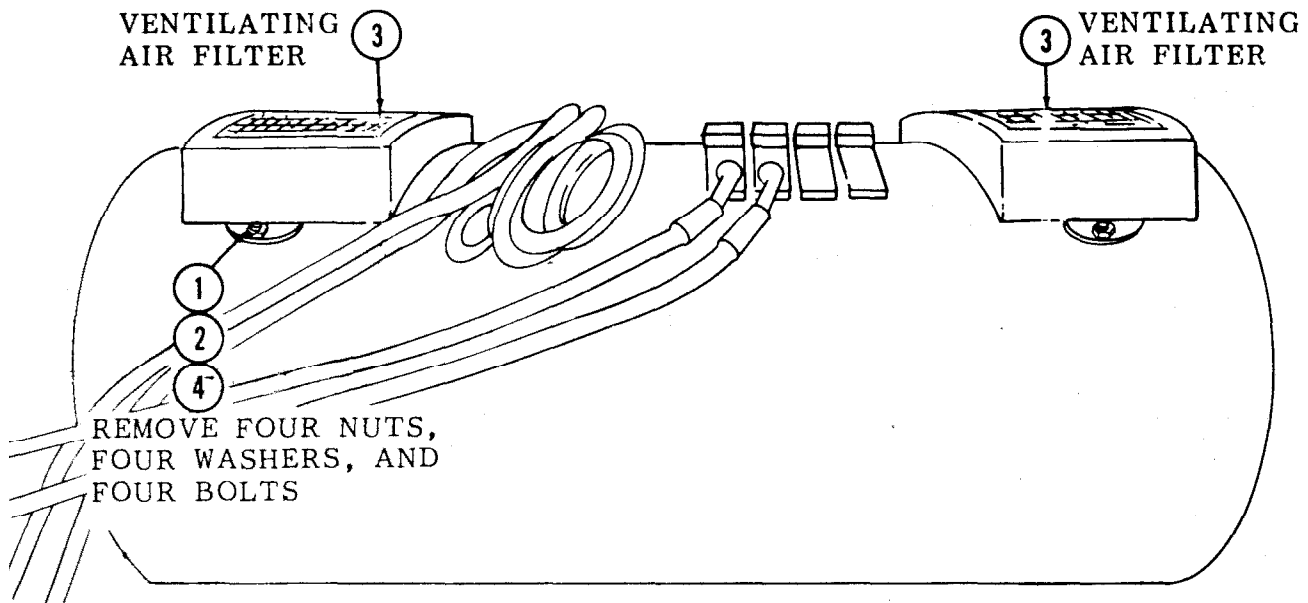
## CHAPTER 13

### MAINTENANCE OF DYNAMOTOR-WELDER

13-1. **GENERAL.** The dynamotor-welder and control cubicle comprise a unit capable of producing 9.6 KW of power for DC welding; and producing 12 KW of AC 3-phase, 60 hertz, power at 0.8 power factor when driven by either the shop set engine or energized by external power. All power received by the various components and outlets of the shop, set, with the exception of the 24-volt DC system, is received from, and controlled by, the control cubicle.

13-2. **VENTILATING AIR FILTERS.**

- a. **Removal.** Remove the nuts and bolts and ventilating air filters as illustrated in figure 13-1.



LEGEND FOR FIGURE 13-1:

ITEM	NSN	P/N	FSCM	QTY
1. Nut, Plain	5310-00-577-2686	50 MS732-0	28835	4
2. Washer, Flat	5310-00-476-5240	W11242-4	28835	4
3. Filter	6125-00-796-8741	16 DW680	28835	2
4. Bolt	5305-00-988-1170	MS35206-284	96906	4

Figure 13-1. Ventilating Air Filters, Removal and Installation.

b. Cleaning and Inspection.

- (1) Clean the air filters with cleaning solvent and blow dry with low-pressure compressed air.
- (2) Inspect filters for breaks, holes, cracks, and other defects and replace a defective filter.
- (3) Inspect filter gasket for defects and replace if defective.

c. Installation. Install the ventilating air filters and secure with nuts and washers as illustrated in figure 13-1.

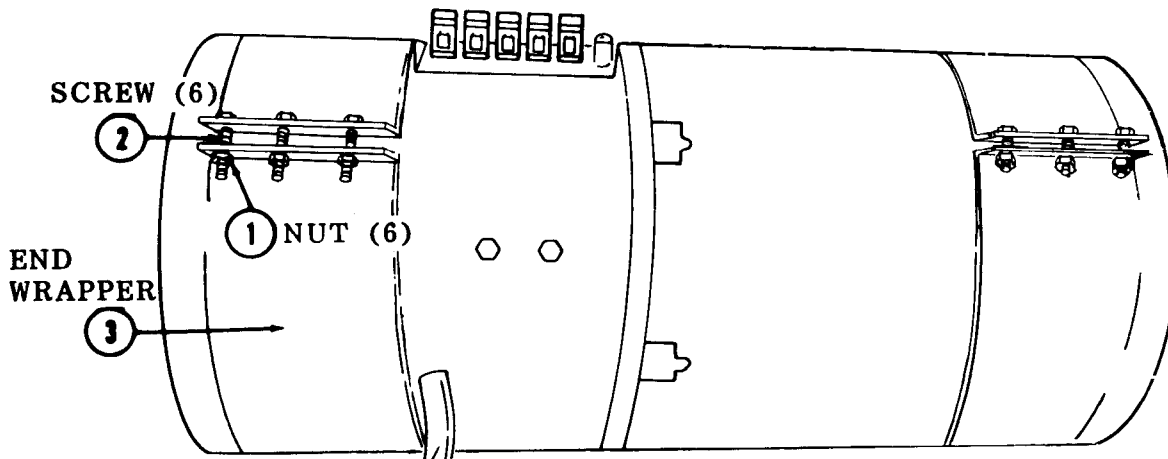
**13-3. END WRAPPERS.**

a. Removal. Remove the screws and nuts and end wrappers as illustrated we 13-2.

b. Cleaning and Inspection.

- (1) Clean end wrappers in cleaning solvent and dry thoroughly.
- (2) Inspect for defects, damage, and for loose or defective hardware.

c. Installation. Install the end wrappers and screws and nuts as illustrated in figure 13-2.



**LEGEND FOR FIGURE 13-2:**

ITEM	NSN	P/N	FSCM	QTY
1. Nut	5310-00-577-2686	50 MS732-0	28835	6
2. Screw	5305-00-990-1347	MS35190-292	96906	6
3. End Wrapper		16 DW679	28835	2

Figure 13-2. Dynamotor-Welder End Wrappers, Removal and Installation.

**13-4. DYNAMOTOR-WELDER BRUSH REPLACEMENT.**

- a. Replacement. Replace and adjust brushes as illustrated in figure 13-3.
- b. Cleaning and Inspection.
  - (1) Clean brushes with a clean, dry lint-free cloth.
  - (2) Inspect for cracks, chips and excessive wear. Replace brushes that are worn to less than 3/4-inch.
- c. Installation. Install the brushes and adjust spring tension as illustrated in figure 13-3.
- d. Seating Brushes. All brushes must be properly seated on the rotating surfaces to insure maximum operating efficiency of the dynamotor-welder. The following contouring procedure applies to all dynamotor-welder brushes.
  - (1) Place a commutator-wide strip of No. 100 sand paper (NSN 5350-00-559-7781) under the brush, abrasive side outward.

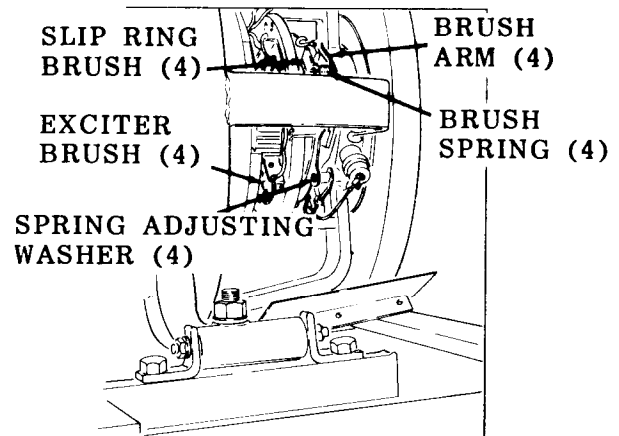
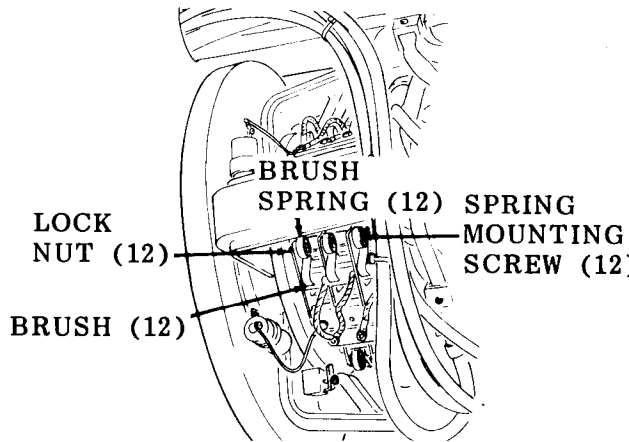
**CAUTION**

Do not use emery cloth when seating brushes as this will short circuit the commutator.

- (2) With the brush in place, press down on the brush and draw the sand paper back and forth until the brush has the same contour as the commutator. Repeat for each brush.
- (3) Test the brush seat by operating the dynamotor-welder for a few minutes, stopping it, and examining the brush set. The seat area should show at least 80 percent highly polished by contact with the rotating surface.

**13-5. OVERSPEED SAFETY SWITCH.**

- a. On-Equipment Testing.
  - (1) Tag and disconnect all electrical leads at the resistor and solenoid coil lead at the terminal.
  - (2) Use a multimeter and test the resistor for smooth increments in resistance from 0 to 1,000 ohms. Replace a defective resistor.
  - (3) Use a multimeter to measure the resistance of the 300 ohm coil. If resistance varies more than plus or minus 2 percent, replace the coil.



NOTE: ALL DIRECT CURRENT WELDER BRUSHES ARE REPLACED IN A SIMILAR MANNER.

NOTE: EXCITER BRUSHES ARE REPLACED IN A SIMILAR MANNER.

A. DIRECT CURRENT WELDER BRUSHES.

B. ALTERNATOR SLIP RING AND EXCITER BRUSHES.

STEP 1. TAG AND DISCONNECT BRUSH AND ELECTRICAL LEADS AS NECESSARY .

STEP 1. TAG AND DISCONNECT BRUSH AND ELECTRICAL LEADS AS NECESSARY.

STEP 2. LIFT BRUSH SPRING AND REMOVE BRUSH FROM HOLDER. REPLACE BRUSHES THAT ARE WORN TO LESS THAN THREE-QUARTERS OF AN INCH.

STEP 2. LIFT BRUSH SPRING AND REMOVE BRUSH FROM HOLDER. REPLACE BRUSHES THAT ARE WORN TO LESS THAN THREE-QUARTERS OF AN INCH.

STEP 3. LIFT BRUSH SPRING AND PLACE BRUSH IN HOLDER.

STEP 3. LIFT BRUSH SPRING AND PLACE BRUSH IN HOLDER.

STEP 4. CONNECT AND SECURE TAGGED BRUSH AND ELECTRICAL LEADS.

STEP 4. CONNECT AND SECURE TAGGED BRUSH AND ELECTRICAL LEADS.

STEP 5. SEAT BRUSHES AS PRESCRIBED IN PARAGRAPH 10-4d.

STEP 5. SEAT BRUSHES AS PRESCRIBED IN PARAGRAPH 10-4d.

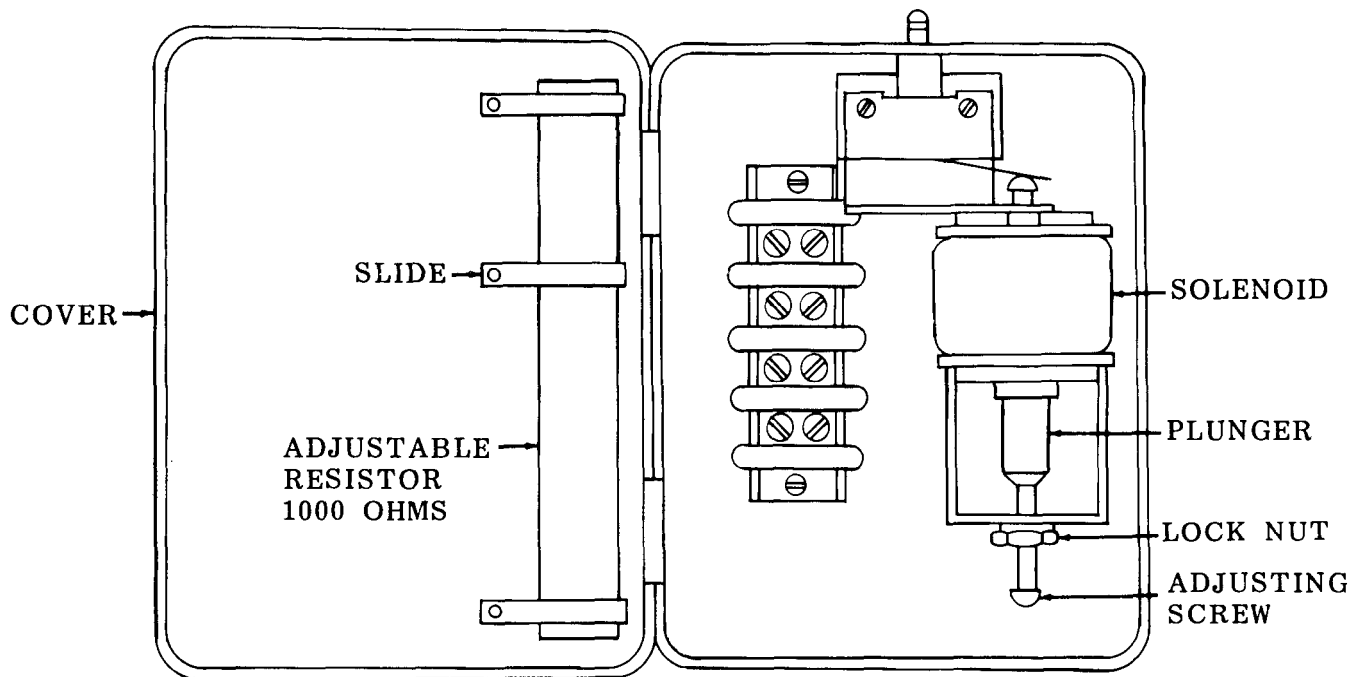
STEP 6. MEASURE BRUSH SPRING TENSION AT FREE END OF BRUSH SPRING. PROPER BRUSH SPRING TENSION IS 24 TO 32 OUNCES. ADJUST BRUSH SPRING TENSION BY LOOSENING LOCK NUT AND TURNING SPRING MOUNTING SCREW. AFTER PROPER BRUSH TENSION IS OBTAINED, TIGHTEN LOCK NUT.

STEP 6. MEASURE BRUSH SPRING TENSION AT FREE END OF BRUSH ARM. PROPER EXCITER BRUSH SPRING TENSION IS 8 TO 12 OUNCES. ADJUST BRUSH SPRING TENSION BY MOVING FREE END OF BRUSH SPRING FROM NOTCH TO NOTCH OF SPRING ADJUSTING WASHER.

Figure 13-3. Dynamotor-Welder Brush Replacement and Tension Adjustment.



- (4) Connect a multimeter to circuits 115 and 116:, continuity should not be indicated. Activate the overspeed switch by hand, if continuity is not indicated, replace the microswitch.
  - (5) Connect previously tagged leads as necessary.
- b. Adjustment. Refer to figure 13-4, and adjust the overspeed safety switch as necessary.
- c. Removal.
- (1) Tag and disconnect the electrical leads.
  - (2) Remove attaching hardware and remove the switch and box.
- d. **Disassembly.** Refer to figure 13-5, and disassemble the overspeed safety switch assembly.
- e. Cleaning and Inspection.
- (1) Clean all electrical components with a clean, dry brush.
  - (2) Clean all parts in an approved cleaning solvent and dry thoroughly.
  - (3) Inspect all Darts for excessive wear. Check the coil for continuity, the solenoid for free movement, and the microswitch for no continuity until switched by hand, then continuity should be indicated.
  - (4) Replace all defective parts.
- f. Reassembly and Installation.
- (1) Reassemble in reverse order of paragraph 13-3.
  - (2) Install safety switch in reverse order of paragraph 13-3.
  - (3) Refer to figure 13-4 and adjust the switch after installation.



STEP 1. USE OHMMETER TO SET SLIDE OF ADJUSTABLE RESISTOR TO GIVE RESISTANCE OF 900 OHMS.

STEP 2. LOOSEN LOCKING NUT. TURN ADJUSTING SCREW COUNTERCLOCKWISE UNTIL SOLENOID PLUNGER BOTTOMS. TIGHTEN LOCKING NUT.

STEP 3. START AND WARM UP THE ENGINE.

STEP 4. START THE DYNAMOTOR-WELDER.

STEP 5. INCREASE ENGINE SPEED UNTIL TACHOMETER READS 1,350 RPM. OVERSPEED SAFETY SWITCH SHOULD SHUT ENGINE DOWN. IF IT FAILS TO DO SO LOOSEN LOCKING NUT. TURN ADJUSTING SCREW CLOCKWISE UNTIL ENGINE STOPS. TIGHTEN LOCKING NUT.

STEP 6. CLOSE AND LATCH OVER SPEED SAFETY SWITCH-COVER.

STEP 7. STOP THE DYNAMOTOR-WELDER.

Figure 13-4. Overspeed Safety Switch Adjustment.

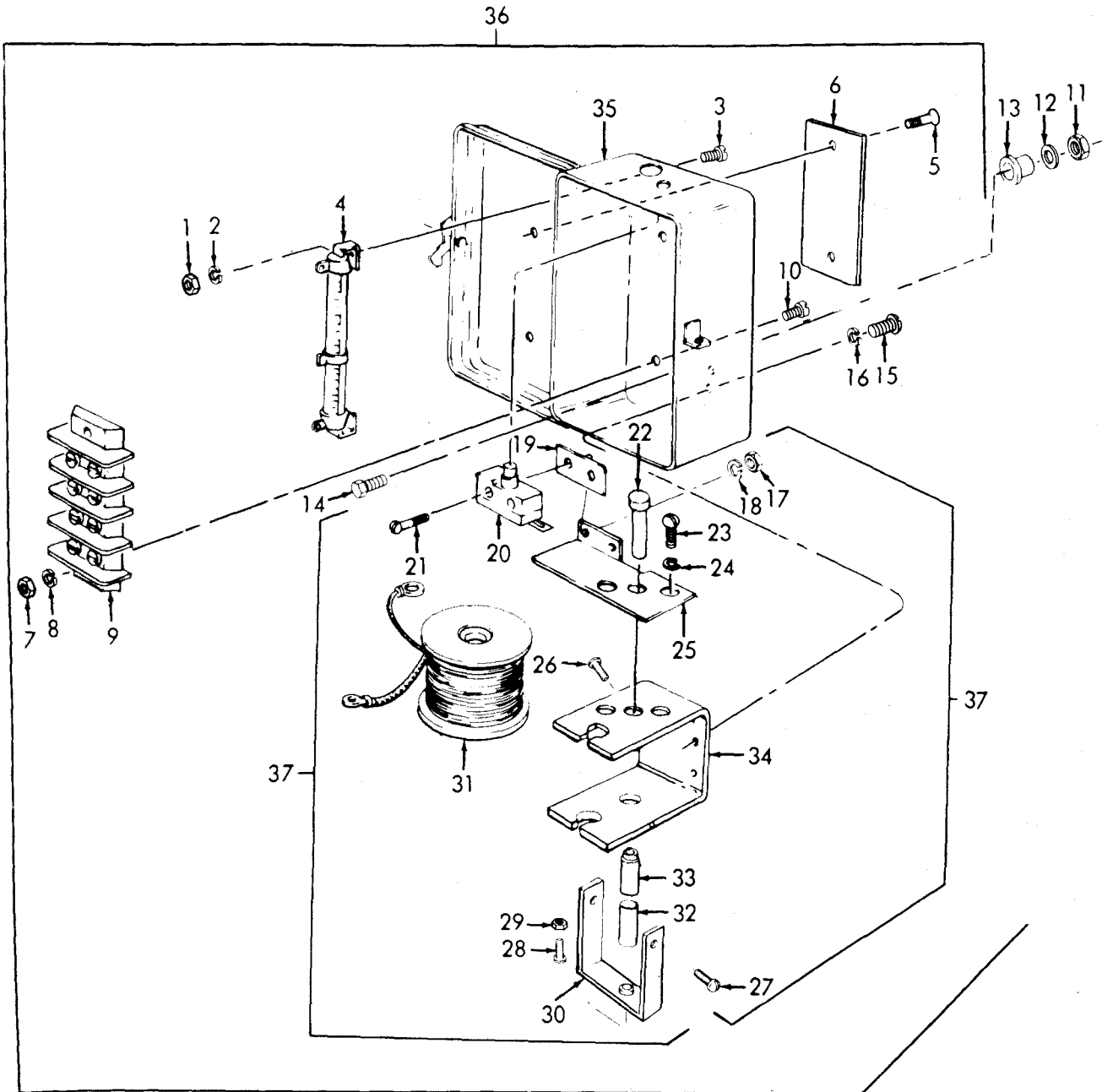


Figure 13-5. Overspeed Safety Switch, Exploded View.

## LEGEND FOR FIGURE 13-5:

ITEM	NSN	P/N	FSCM	QTY
1. Nut	5310-00-934-9747	MS35649-262	96906	2
2. Washer	5310-00-045-4007	MS35338-41	96906	2
3. Screw	5305-00-984-4989	MS35206-229	96906	2
4. Resistor	5905-00-107-8909	C962	44655	1
5. Screw		W11234-1	28835	2
6. Plate		DW5027	28835	1
7. Nut		T0632005	77122	2
8. Washer	5310-00-889-2708	MS45904-54	96906	2
9. Terminal Board	5940-00-949-8313	404	38151	1
10. Screw	5305-01-039-2497	W11110-6	28835	2
11. Nut		MS51967-2	96906	4
12. Washer	5310-00-045-3296	MS35338-43	96906	4
13. Spacer		13217E1210	59678	4
14. Screw	5305-00-071-2240	MS90725-11	96906	4
15. Screw		5CW1308-1	28835	2
16. Washer	5310-00-889-2527	MS45904-72	96906	2
17. Nut	5310-00-934-9747	MS35649-262	96906	2
18. Washer	5310-00-045-4007	MS35338-41	96906	2
19. Insulation		50MS586	28835	1
20. Switch		B ZRLX2	91929	1
21. Screw	5305-00-984-6221	MS24584-31	96906	2
22. Pin		DW6608	28835	1
23. Screw	5305-00-988-1720	MS35206-276	96906	2
24. Washer	5310-00-582-5965	MS35338-44	96906	2
25. Bracket		DW5018	28835	1
26. Screw	5305-00-889-3001	MS35206-231	96906	1
27. Screw	5305-00-984-4983	MS35260-226	96906	2
28. Screw	5305-00-531-0202	MS35214-73	96906	1
29. Nut	5310-00-924-4218	MS51970-1	96906	1
30. Relay Core		X188481	01121	1
31. Coil	5950-00-966-2086	DATA1355	28835	1
32. Plunger		5CW3546	28835	1
33. Support Plunger	5945-00-420-1278	5CW3547	28835	1
34. Frame		5CW3545	28835	1
35. Box		DW5C19	28835	1
36. Relay, Overspeed		13217E1432	59678	1
37. Relay, Overspeed	3431-00-803-3507	DW5017A	28835	2

**13-6. ON-EQUIPMENT ELECTRICAL TESTS.**a. Alternating Current Stator.

- (1) Tag and disconnect motor leads at terminal board 5CW5063.
- (2) Use a multimeter to test continuity between stator leads B and 1B, 2B and 3B, A and 1A, 2A and 3A, C and 1C, 2C and 3C. If continuity is not indicated, the alternating current stator must be replaced.
- (3) Use a multimeter to test insulation resistance between the dynamotor-welder frame and motor leads A and 2A, B and 2B, C and 2C. If any reading on the multimeter is less than 0.5 megohm, faulty insulation is indicated, and dynamotor-welder must be removed for further testing.
- (4) Use a multimeter to test insulation resistance between stator lead 1B and leads 3B, C, 2C, A, 2C, 2A; between stator lead 3B and leads C, 2C, A, 2A; between stator lead C and leads 2C, A, 2A; between stator lead 2C and leads A, 2A; between stator leads A and 2A. A reading of less than 0.5 megohm indicates faulty insulation and the dynamotor-welder must be removed for further testing.

b. Revolving Fields.

- (1) Raise the revolving field brushes from the sliprings.
- (2) Use a multimeter to test resistance between the two slip rings. A resistance greater than 10 percent above or below 45 ohms indicates faulty winding and the rotor must be removed for further testing.
- (3) Use a multimeter to test resistance between either slipring and the rotor shaft. A resistance reading of less than 0.5 megohm indicates faulty insulation and rotor must be removed for further testing.

c. Exciter Armature.

- (1) Raise the exciter brushes from the exciter armature.
- (2) Use a multimeter to test insulation resistance between the rotor shaft and one of the exciter commutator bars; repeat this using at least two other bars around the commutator. If any reading is less than 0.5 megohm, faulty insulation is indicated and the dynamotor-welder must be removed for further testing.

d. Exciter Field.

- (1) Tag and disconnect exciter field leads at terminal board 5CW5063.

- (2) Raise the brushes from both sliprings and the exciter commutator.
- (3) Use a multimeter to test the resistance between exciter leads 104 and 105. If the resistance is greater than 10% above or over 65 ohms, the field winding is faulty and the field frame must be removed for further testing.
- (4) Use a multimeter to test insulation resistance between the field and any one of the field leads. A resistance reading of less than 0.5 megohm indicates faulty insulation and the field frame must be removed for further testing.

e. Shunt Field (Welder-Generator).

- (1) Tag and disconnect shunt field leads at terminal boards DW4004 and DW4005.
- (2) Use a multimeter to test resistance between leads 101 and 102. A resistance reading of more than 5% above 27.5 ohms indicates a faulty winding and the field frame must be removed for further testing.
- (3) Use a multimeter to test insulation resistance between the field frame and any one of the field leads. A resistance reading of less than 0.5 megohm indicates faulty insulation and the field frame must be removed for further testing.

**13-7. DYNAMOTOR-WELDER WORK TABLE.**

- a. Removal. Remove seven bolts, lockwashers, and nuts, that secures the work table to lathe table and van body.
- b. Cleaning, Inspection, and Repair.
  - (1) Clean the table and all parts with an approved cleaning solvent and dry thoroughly.
  - (2) Inspect for cracks, breaks, warpage, and other damage.
  - (3) Weld minor breaks and straighten warpage and bent table supports if feasible.
  - (4) Replace defective parts or table that is damaged beyond repair.
- c. Installation. Install in reverse order of paragraph 13-8a.

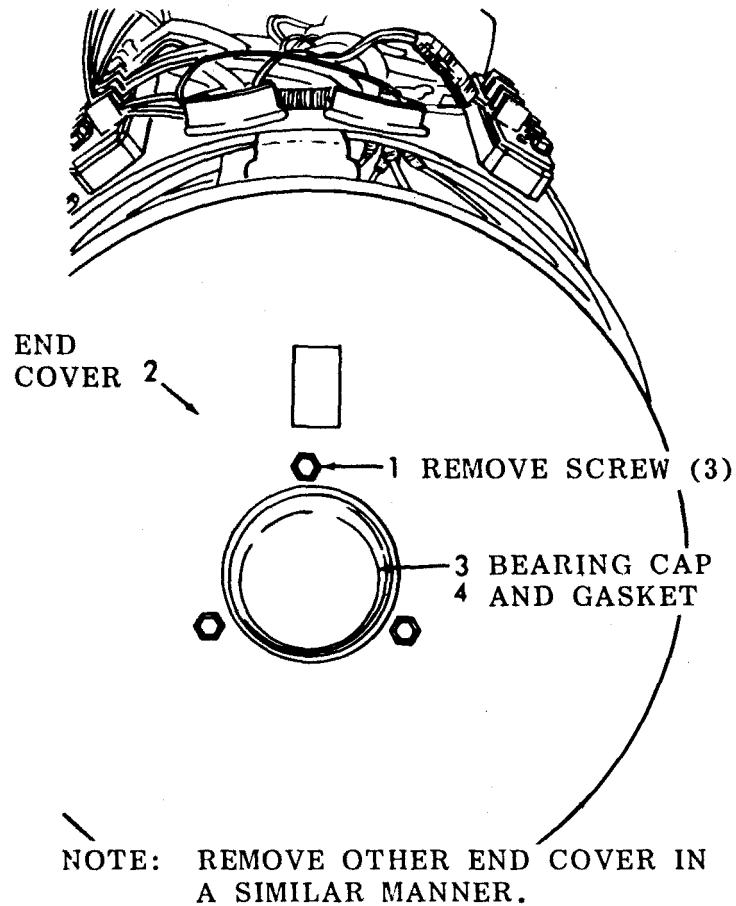
**13-8. END COVERING AND BEARING CAP.**

- a. Removal.
  - (1) Remove dynamotor-welder end wrappers.
  - (2) Remove end cover and bearing cap as illustrated in figure 13-6.

b. Installation.

(1) Install the end cover and bearing cap as illustrated in figure 13-6.

(2) Install dynamotor-welder end wrappers.



LEGEND FOR FIGURE 13-6:

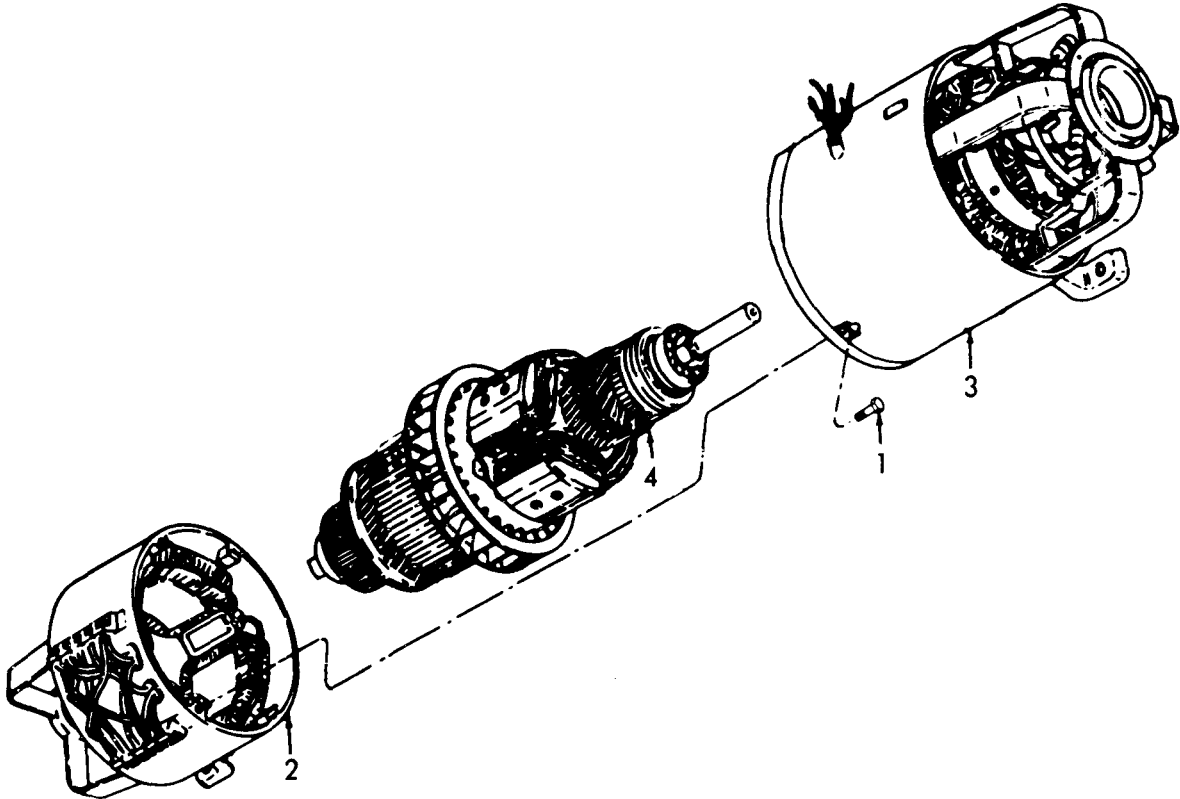
ITEM	NSN	P/N	FSCM	QTY
1. Screw	5305-00-004-1569	50 W1308-3	28835	3
2. Cover, End	6115 -00-794-1040	160W681	28835	1
3. Cap	3110-00-447-4249	DW-882-A	28835	1
4. Gasket	5330-00-447-4250	DW883	28835	1

Figure 13-6. End Cover and Bearing Cap, Removal and Installation.

13-9. ARMATURE AND BEARINGS.

a. Removal.

- (1) Remove dynamotor-welder brushes (para. 13-4).
- (2) Remove the armature as illustrated in figure 13-7.



LEGEND FOR FIGURE 13-7:

ITEM	NSN	P/N	FSCM	QTY
1. Screw	5305-01-038-8651	W11097-4	28835	4
2. Motor Housing		16 DW69A3	28835	1
3. Motor Housing		16 DW731-2	28835	1
4. Armature	6125-00-735-9065	16 DW736	28835	1

Figure 13-7. Dynamotor-Welder Armature, Removal and Installation.



b. Testing.

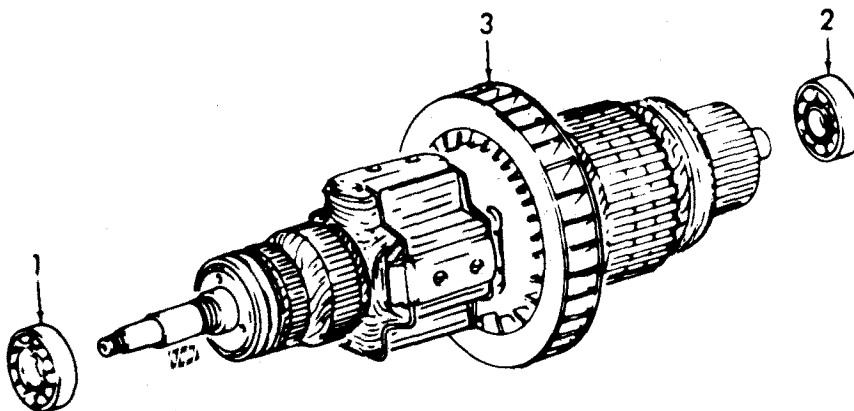
- (1) Test the windings of the exciter and direct current welder portions of the armature for insulation resistance, open circuits, and short circuits, as directed in TM 5-764. Resistance between any two commutator bars of either exciter or welder portion should be 0.25 ohm.
- (2) Tag and disconnect the wiring leads from the armature sliprings and test the windings of the alternator portion of the armature for insulation resistance of 10 ohms, plus or minus 10 percent, open circuits, and short circuits as directed in TM 5-764.

c. Disassembly. Refer to figure 13-8 and disassemble the armature in numerical sequence.

d. Reassembly. Refer to figure 13-8 and reassemble armature in reverse numerical sequence and manner. Before reassembly, clean and repack bearings with grease, automotive and artillery (GAA).

e. Installation.

- (1) Install the armature as illustrated in figure 13-7.
- (2) Install the dynamotor-welder brushes (para. 13-4).



LEGEND FOR FIGURE 13-8:

ITEM	NSN	P/N	FSCM	QTY
1. Bearing	3110-00-227-3618	FW2502	28835	1
2. Bearing	3110-00-227-3618	FW2502	28835	1
3. Armature		351557	28835	1

Figure 13-8. Dynamotor-Welder Armature, Disassembly and Assembly.

**13-10. FIELD COILS, POLE SHOES, BRUSH HOLDERS, AND MOUNTING RINGS.**

- a. Testing. Test the exciter field coils, alternator stator, and direct current field and interpole poles as directed in TM 5-764.
- b. Removal and Installation, Disassembly and Reassembly.
  - (1) Refer to paragraph 13-9 for removal and installation of the dynamotor-welder armature.
  - (2) Refer to figure 13-9 and disassemble dynamotor-welder frames, field coils, pole shoes, brush holders, and mounting rings in numerical sequence.
  - (3) Refer to figure 13-9, and reassemble dynamotor-welder frames, field coils, pole shoes, brush holders, and mounting rings in reverse numerical sequence and manner.

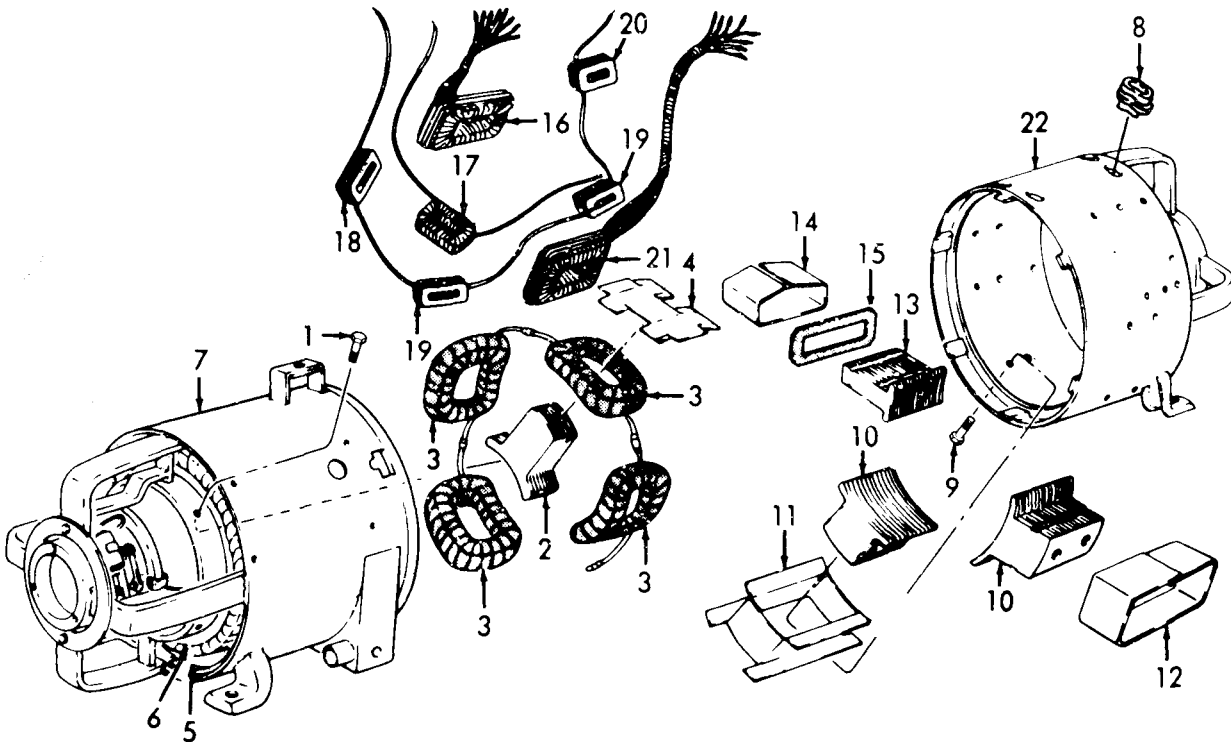
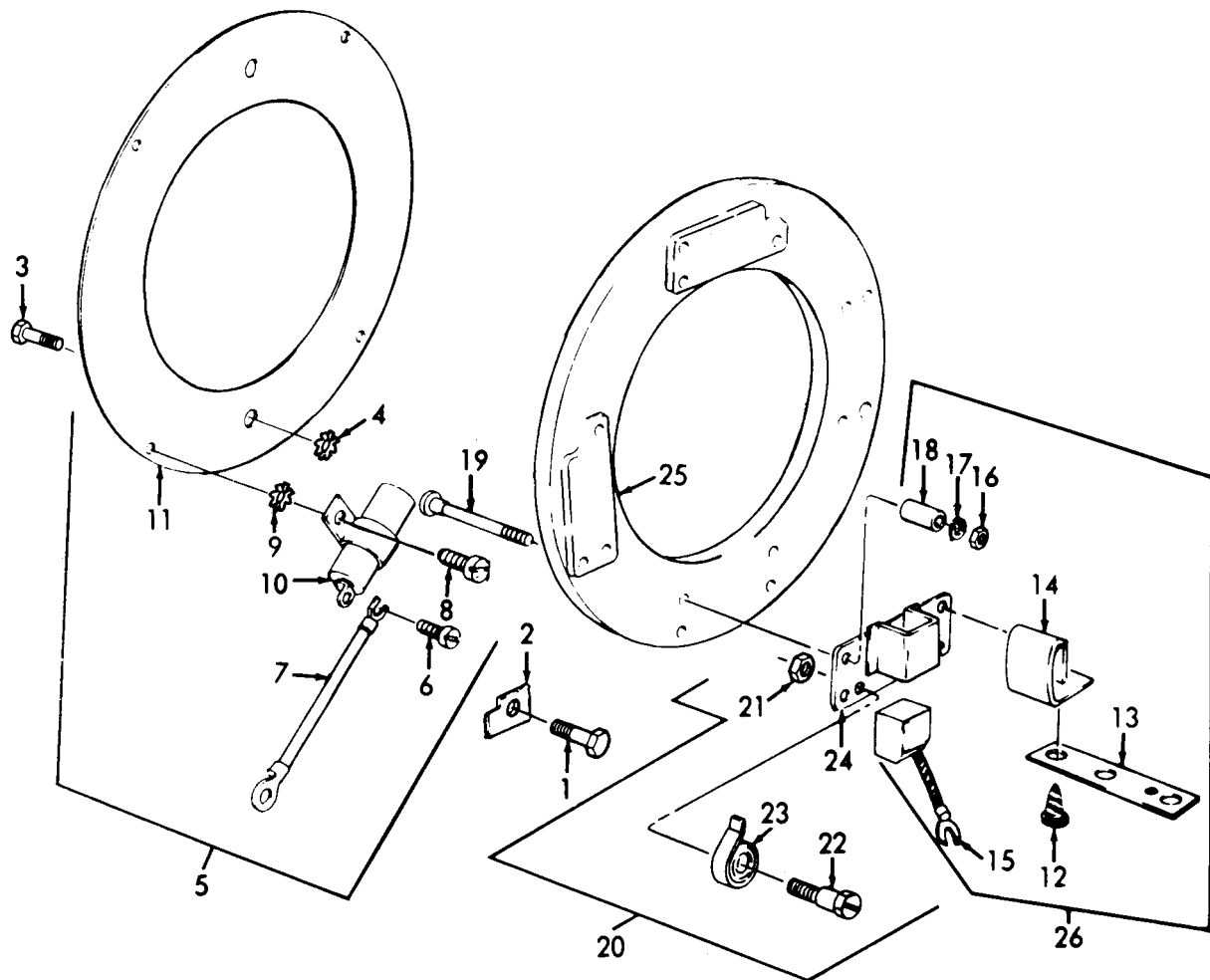


Figure 13-9. Dynamotor-Welder Frames, Field Coils, Pole Shoes, Brush Holders and Mounting Rings, Exploded View (Sheet 1 of 3).

## LEGEND FOR FIGURE 13-9 (Sheet 1 of 3):

ITEM	NSN	P/N	FSCM	QTY
1. Screw		W11097-3	28835	4
2. Pole Piece	5999-00-458-7905	BW97	28835	4
3. Winding	6115-00-354-2313	DATA1512	28835	1
4. Insulator	5970-00-698-7184	AW720B	28835	4
5. Stator		4DW536	28835	1
6. Winding	6105-00-186-6535	DATA2414	28835	1
7. Housing		16DW731-2	28835	1
8. Bushing	5970-00-371-5455	FW793B	28835	6
9. Screw		W11097-6	28835	16
10. Magnet Permanent	5999-00-427-0806	DW1045	28835	6
11. Insulator Plate	5970-00-447-4193	AW106	28835	8
12. Wrapper		DW424	28835	4
13. Pole Piece	5999-00-213-1216	DW1077A	28835	4
14. Insulator Plate	5970-00-295-9611	S8192-3B010	28835	4
15. Collar		DW6373	28835	12
16. Compound		DW6734	28835	1
17. Winding	6115-00-242-8063	DATA1065	28835	1
18. Coil		16DW255	28835	1
19. Winding Generator	6115-00-354-2316	DW1079A	28835	2
20. Coil	6115-00-433-5950	DW6725	28835	1
21. Compound		DW6735	28835	1
22. Housing		16DW69A3	28835	1



DIRECT CURRENT BRUSH HOLDERS AND MOUNTING RING

Figure 13-9. Dynamotor-Welder Frames, Field Coils, Pole Shoes, Brush Holders, and Mounting Rings, Exploded View (Sheet 2 of 3).

## LEGEND FOR FIGURE 13-9 (Sheet 2 of 3):

ITEM	NSN	P/N	FSCM	QTY
1. Screw	5305-00-890-4790	W11236-5	28835	2
2. Clamp		12CW74A	28835	2
3. Screw	5305-01-038-6358	W11236-4	28835	2
4. Washer	5310-00-637-9575	4014-20-00	78189	2
5. Shield		8BW758	28835	1
6. Screw	5305-00-285-5282	451626	24617	7
7. Lead		8BW804-5	28835	2
7. Lead		8BW804-6	28835	1
7. Lead	6150-00-437-6601	8BW804-1	28835	4
8. Screw	5305-01-040-0997	W11224-2	28835	7
9. Washer	5310-00-261-6192	4008-14-00	78189	7
10. Capacitor	5910-00-882-0556	B206143	90201	3
10. Capacitor	5910-00-367-7862	CA37KFW254	81349	4
11. Ring		12CW64	28835	2
12. Screw	5305-00-869-4614	W11236-2	28835	8
13. Bus Conductor	6150-01-045-0507	16DW200	28835	4
14. Bracket Busbar	5977-01-055-5225	AW1683	28835	8
15. Brush	5977-00-655-2555	AW1470	28835	12
16. Nut	5310-00-850-4770	AW640	28835	12
17. Washer	5310-00-487-1289	W11254-4	28835	12
18. Spacer	5365-01-046-1096	AW740	28835	8
19. Bolt	5306-00-005-0496	8BW12-2	28835	12
20. Holder	5977-00-038-8676	AW1156	28835	12
21. Nut	5310-00-850-4770	AW640	28835	12
22. Adapter		AW1719	28835	12
23. Spring	5360-00-431-8923	W799H173	28835	12
24. Guide	5977-00-019-8676	AW734A	28835	12
25. Ring	5877-00-922-0875	12CW962	28835	1
26. Brush Holder Assy.		16DW77B	28834	1

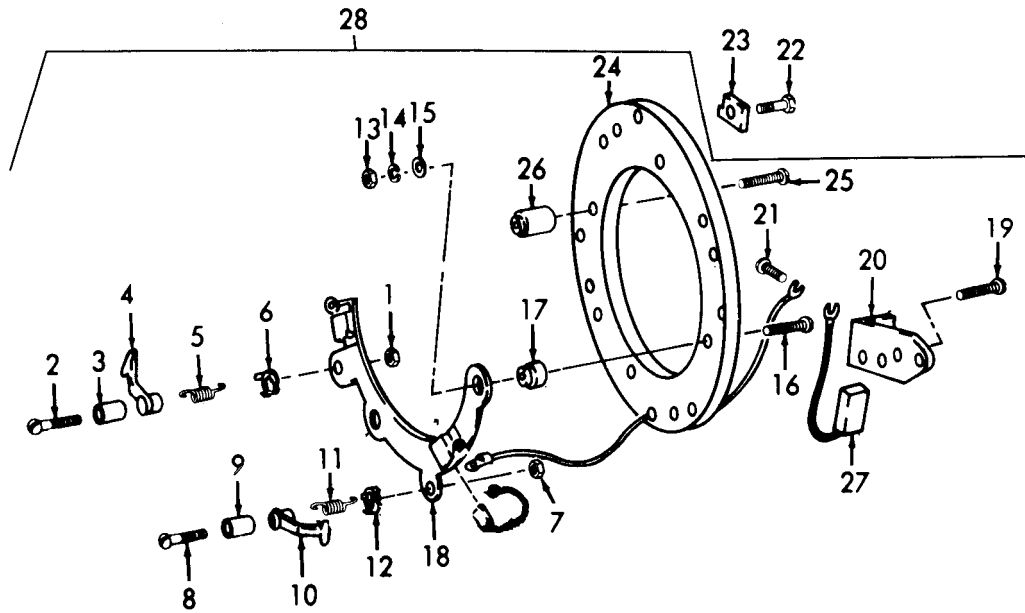


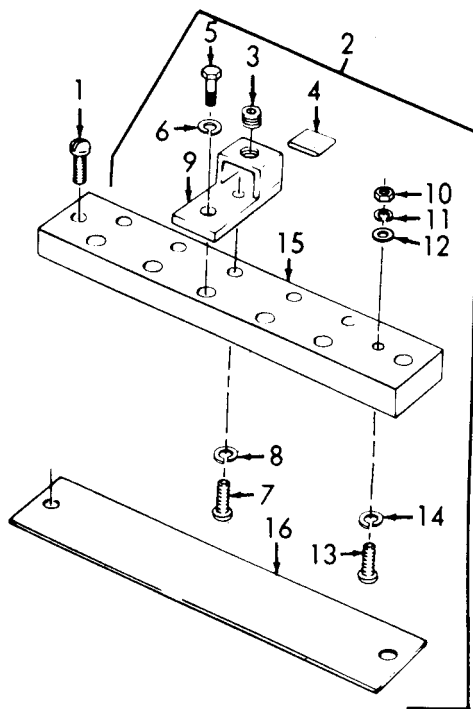
Figure 13-9. Dynamotor-Welder Frames, Field Coils, Pole Shoes, Brush Holders, and Mounting Rings, Exploded View (Sheet 3 of 3).

## LEGEND FOR FIGURE 13-9 (Sheet 3 of 3):

ITEM	NSN	P/N	FSCM	QTY
1. Nut	5310-00-850-4770	AW640	28835	4
2. Screw	5305-00-004-1553	W11114-4	28835	4
3. Bushing, Sleeve	3120-00-447-4202	AW667A	28835	4
4. Arm	5977-00-234-7463	AW634	28835	4
5. Spring	5360-00-817-1119	W799D92B	28835	4
6. Washer	5977-00-735-6143	AW638C	28835	4
7. Nut	5310-00-850-4770	AW640	28835	4
8. Scre w	5305-00-004-1553	W11114-4	28835	4
9. Bushing, Sleeve	3120-00-447-4202	AW667A	28835	4
10. Arm	5977-00-234-7643	AW634	28835	4
11. Spring	5360-00-817-1119	W799092B	28835	4
12. Washer	5977-00-735-6143	AW638C	28835	4
13. Nut	5310-00-851-2674	MS35691-1	96906	4
14. Washer	5310-00-487-1289	W11254-4	28835	4
15. Washer	5310-00-480-4143	W11242-5	28835	4
16. Screw	5305-00-988-1170	MS35206-284	96906	2
17. Spacer		12CW1369	28835	2
18. Retainer	5977-00-374-5132	J392A	28835	2
19. Screw	5305-01-059-0169	W11225-2	28835	8
20. Plate and Guide	5977-00-429-0936	AW696	28835	4
21. Screw		W11224-1	28835	4
22. Screw	5305-00-890-4790	W11236-5	28835	2
23. Clamp		12CW74A	28835	2
24. Ring		12CW81A	28835	1
25. Screw	5305-00-988-9265	MS35206-286	96906	2
26. Spacer		12CW1370	28835	2
27. Brush	5977-00-361-7784	DW825	28835	4
28. Holder Assy, Brush	5977-00-841-5204	12DW1371	28835	1

13-11. TERMINAL BOARDS.

- a. Removal. Remove the terminal boards as illustrated in figures 13-10 and 13-11.
- b. Installation. Install the terminal boards as illustrated in figures 13-10 and 13-11.

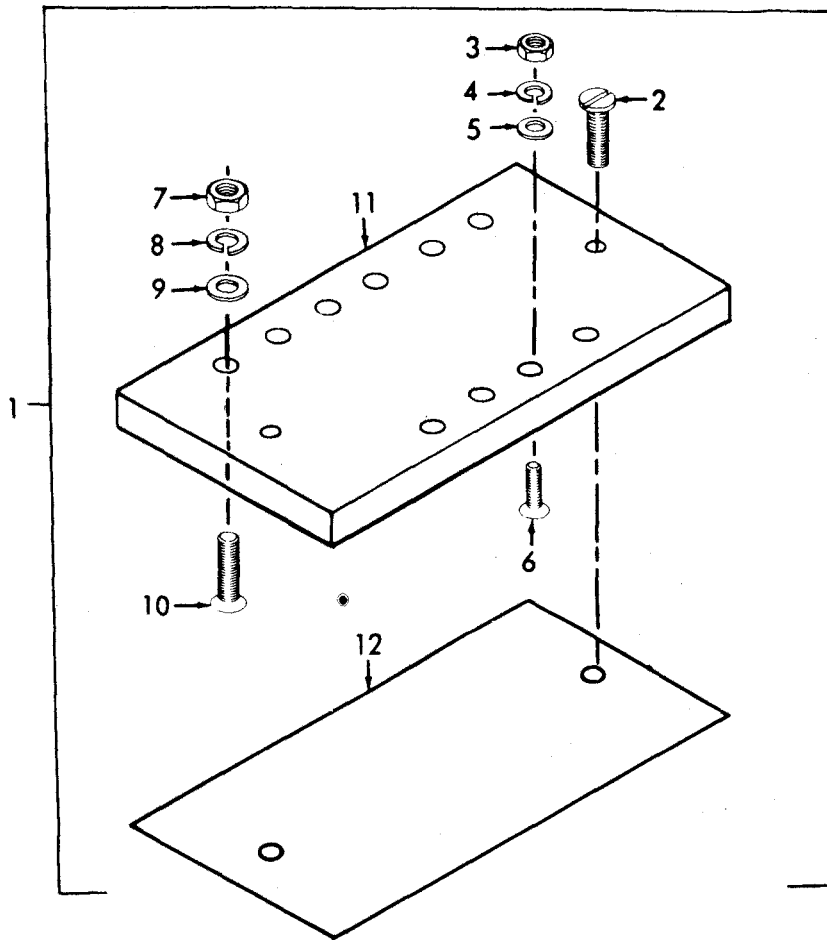


LEGEND FOR FIGURE 13-10:

ITEM	NSN	P/N	FSCM	QTY
1. Screw, Machine	5305-01-056-1485	W11112-8	28835	4
2. Terminal Block	5940-00-798-7558	<del>DW4014</del>	28835	1
2. Terminal Block		DW4016	28835	1
3. Setscrew	5305-01-057-8128	W11137-1	28835	15
4. Plate		DW4453	28835	18
5. Screw	5305-00-869-5008	5CW1308-2	28835	10
6. Washer, Lock	5310-00-707-0690	W11254-5	28835	10
7. Screw	5305-01-057-3040	88W824-C	28835	10
8. Washer, Lock	5310-00-982-5965	MS35338-44	96906	10
9. Terminal, Lug	5940-01-045-0689	DW4026	28835	10
10. Nut, Lock	5310-00-206-1918	22804	72962	4
11. Washer, Lock	5310-00-487-1296	W11254-3	28835	4
12. Washer, Flat	5310-00-763-0253	W11245-3	28835	4
13. Screw, Machine	5305-00-720-7945	88W823-0	28835	2
14. Washer, Lock	5310-00-045-3296	MS35338-43	96906	2
15. Block, Terminal		DW4004	28835	1
16. Insulator	5970-00-434-4844	DW6724	28835	2

Figure 13-10. Terminal Board, Removal and Installation.





LEGEND FOR FIGURE 13-11:

ITEM	NSN	P/N	FSCM	QTY
1. Terminal Board	5940-01-048-5380	5DW40WC	28835	1
2. Screw, Machine	5305-01-056-1485	W11112-8	28835	2
3. Nut, Plain	5310-01-037-9265	W11287-4	28835	8
4. Washer, Lock	5310-00-487-1296	W11254-3	28835	8
5. Washer, Flat	5310-00-476-5230	W11242-3	28835	8
6. Screw, Hex, Jam	5305-00-851-2675	MS35691-1	96906	4
7. Nut, Plain	5310-00-492-3145	W11280-2	28835	12
8. Washer, Lock	5310-00-487-1289	W11254-4	28835	12
9. Washer, Flat	5310-00-620-4143	W11242-5	28835	12
10. Screw, Machine	5310-00-720-4632	88W824-2	28835	6
11. Block, Terminal	5970-00-434-4844	5DW5063-1	28835	1
12. Insulator, Plate	5970-00-434-4844	DW6724	28835	1

Figure 13-11. Motor Terminal Board, Removal and Installation.

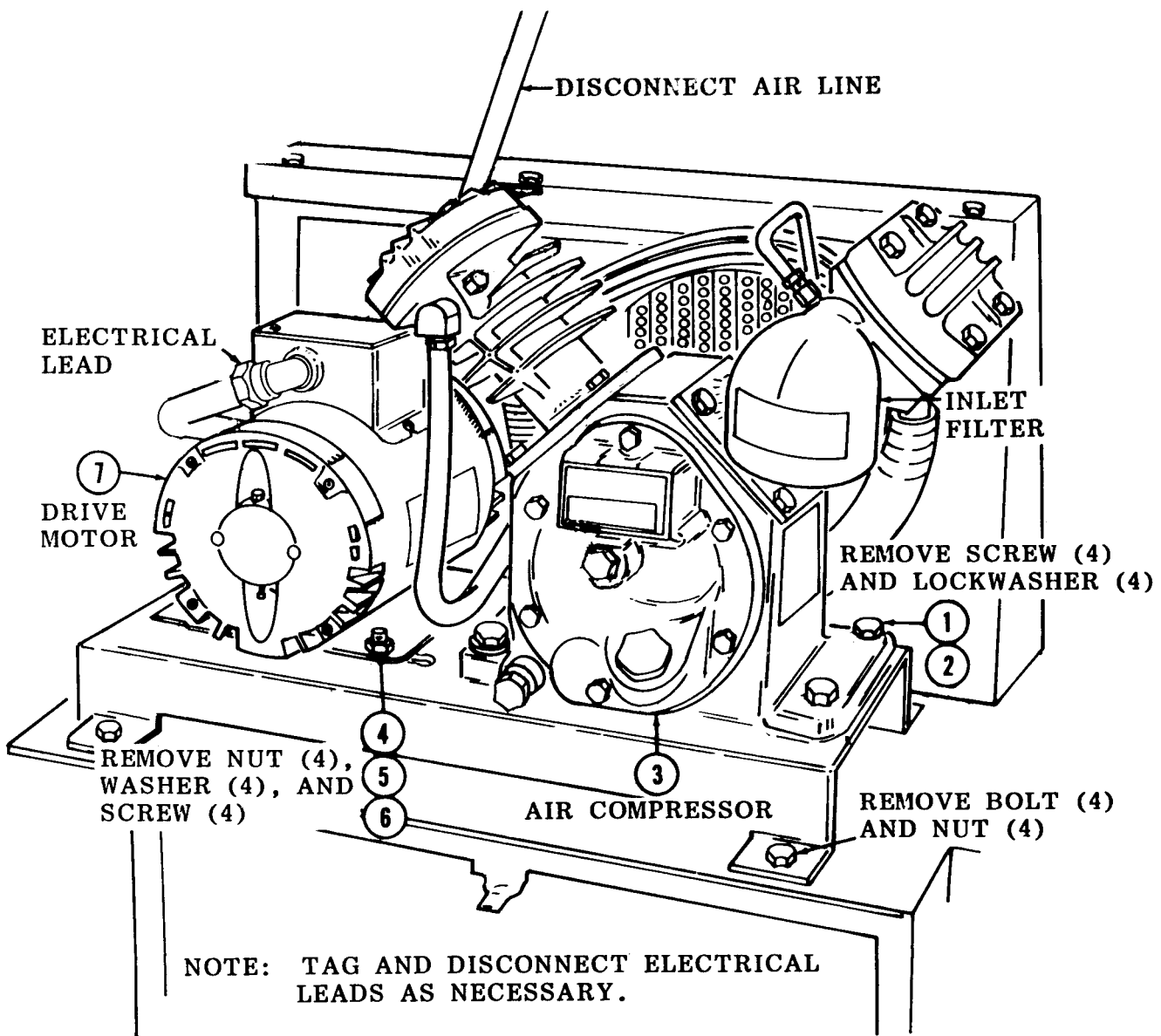


## CHAPTER 14

### MAINTENANCE OF AIR COMPRESSOR AND RELATED PARTS

---

- 14-1. GENERAL.** The two-stage air compressor is driven by a 2-horse-power motor. The items comprise a self-contained unit delivering an adequate volume of air to the air receiver tank to maintain an air pressure differential of 125 to 150 psi. The air receiver tank is an integral part of the shop set roof. The air receiver tank pressure gage indicates the pressure in the tank. A pop-off valve set at 175 psi prevents the system from becoming overloaded. A draincock beneath the tank provides a means of draining the condensation out of the system before usage. This should be done daily, before the compressor is put into use.
- 14-2. AIR COMPRESSOR.**
- a. Removal (Refer to figure 14-1).
    - (1) Disconnect and tag electrical leads at motor.
    - (2) Disconnect air line to receiver.
    - (3) Remove four bolts and four lockwashers securing air compressor base to cabinet.
  - b. Installation. Install the air compressor and drive motor in reverse order of removal.
- 14.3. AIR COMPRESSOR DRIVE MOTOR ASSEMBLY.**
- a. Removal. Tag and disconnect electrical lead (fig. 14-1). Remove four bolts and nuts and remove drive motor assembly.
  - b. Installation. Install the drive motor assembly in reverse order of paragraph a. Adjust fan belt to a  $\frac{1}{2}$ -inch deflection between pulleys.
- 14-4. AIR COMPRESSOR PRESSURE SWITCH.**
- a. Adjustment.
    - (1) To raise CUT-IN and CUT-OUT pressure, turn pressure adjusting screw clockwise.
    - (2) To lower DIFFERENTIAL (namely the difference between CUT-IN and CUT-OUT pressure), turn differential screw at edge counterclockwise. When adjusting this screw, do not turn it further than it will turn easily.
    - (3) To increase DIFFERENTIAL and maintain same CUT-OUT pressure, turn differential screw at edge clockwise and at the same time turn center screw counterclockwise.



LEGEND FOR FIGURE 14-1:

ITEM	NSN	P/N	FSCM	QTY
1. Screw	5305-00-782-9495	MS9C725-111	96906	4
2. Washer, Lock	5310-00-584-5272	MS35338-48	96906	4
3. Compressor, Air	4310-00-255-0434	L49780	51436	1
4. Nut	5310-00-880-7744	MS51967-5	96906	4
5. Washer	5310-00-407-9566	MS35338-45	96906	4
6. Screw	5305-00-225-9081	MS90725-36	96906	4
7. Motor		145TTDR8 350AA	38151	1

Figure 14-1. Air Compressor and Drive Motor Assembly, Removal and Installation.

**NOTE**

If differential is increased only by turning screw at edge clockwise, the CUT-IN pressure changes only slightly and the CUT-OUT pressure rises.

**14-5. INLET AIR FILTER.**

- a. General. The inlet air filter is designed to filter the air entering the first stage cylinder. Should the operating area be exceptionally dusty, it must be serviced more frequently so the pads will collect more dust and minimize cylinder wear. A clogged intake filter reduces the efficiency of the compressor.
- b. Removal. Remove the inlet filter as illustrated in figure 14-2.
- c. Installation. Install the inlet filter in reverse order of removal (fig. 14-2).

**14-6. AIR RECEIVER TANK POP-OFF VALVE.**

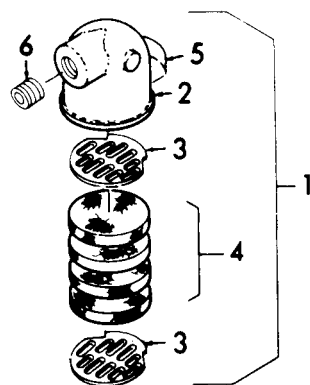
- a. Removal.
  - (1) Remove the air receiver tank pop-off valve as illustrated in figure 14-3.
  - (2) Remove bushing from pop-off valve.

**NOTE**

No further disassembly is required for cleaning.

- b. Cleaning and Inspection.
  - (1) Clean all parts with cleaning solvent and dry thoroughly.
  - (2) Inspect for defects and replace a defective pop-off valve, as necessary.
- c. Adjustment.
  - (1) Loosen locknut and turn adjustment nut clockwise to raise pop-off valve pressure and counterclockwise to lower pop-off valve pressure.
  - (2) Tighten locknut.

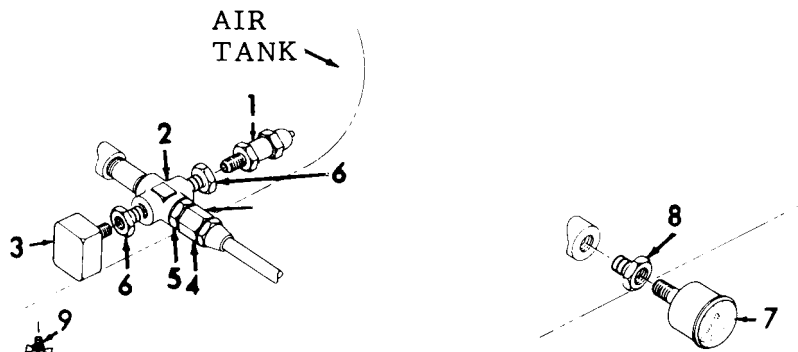
Bolt, Machine



LEGEND FOR FIGURE 14-2:

ITEM	NSN	P/N	FSCM	QTY
1. Filter Complete	4310-00-386-6549	3W75298T4C	30760	1
2. Body	4310-00-025-2355	3W11558	30760	1
3. Disc	4310-00-405-9732	3W6C504	88663	2
4. Pad	4310-00-253-0871	3W6C506	88663	4
5. Decal		3W75251	51436	1
6. Nipple		18A7W5	30760	1

Figure 14-2. Inlet Filter, Exploded View.



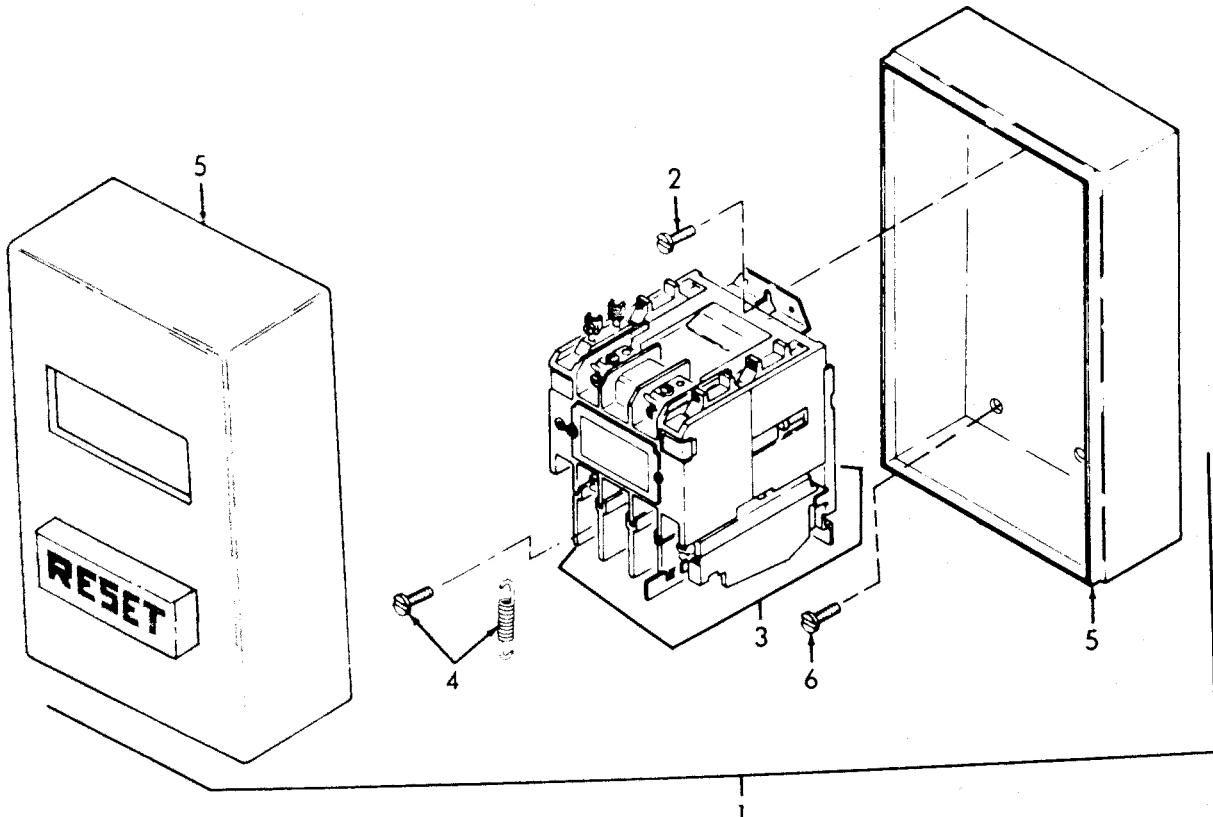
LEGEND FOR FIGURE 14-3:

ITEM	NSN	P/N	FSCM	QTY
1. Valve	4820-00-452-9304	13217E1085	59678	1
2. Cross Pipe		MS14303-5BSU	96906	1
3. Switch, Pressure		13217E8321-1	59678	1
4. Valve, Check	4820-01-099-9567	CA-12	58818	
5. Bushing, Pipe	4730-00-202-6663	MS51887-15	96906	1
6. Bushing, Pipe		MS51887-14	96906	2
7. Gage, Pressure	6685-01-064-6516	13217E1084	59678	1
8. Bushing		13218E0112-5	97403	1
9. Valve, Needle		13217E1065-1	19204	1

Figure 14-3. Air Receiver Tank Pop-Off Valve.

14-7. COMPRESSOR STARTER CONTROL BOX.

- a. Removal. Remove three screws (6, figure 14-4) and remove the starter control box.
- b. Disassembly. Disassemble the starter control box as illustrated in figure 14-4.



LEGEND FOR FIGURE 14-4:

ITEM	NSN	P/N	FSCM	QTY
1. Starter Control Box		11021091	59678	1
2. Screw	Part of # 1			2
3. Starter		14 CF34BA71	23826	1
4. Heater Element		E51	23826	1
5. Enclosure	Part of # 3		2382 <sup>c</sup>	1
6. Screw	Part of # 3			3

Figure 14-4. Compressor Starter Control Box, Exploded View.

- c. Cleaning, Inspection, and Repair.
  - (1) Clean parts with cleaning solvent and wipe dry.
  - (2) Inspect the movable and stationary contacts for burns, pitting and corrosion. Inspect all parts for burns and for brittle condition. Inspect for-frayed insulation.
  - (3) Check selector switch for continuity with a multimeter.
  - (4) Replace defective parts as necessary.
- d. Reassembly. Reassemble the starter control box as illustrated in figure 14-4.
- e. Installation. Install the starter control box.

**14-8. PRESSURE SWITCH.**

- a. Removal.
  - (1) Remove cover on pressure switch (fig. 14-5).
  - (2) Disconnect air line.
  - (3) Tag and disconnect electrical leads from pressure switch.
  - (4) Remove conduit locknuts and remove pressure switch.
- b. Installation. Install in reverse order of removal.
- c. Adjustment. Refer to paragraph 14-4 for adjustment.

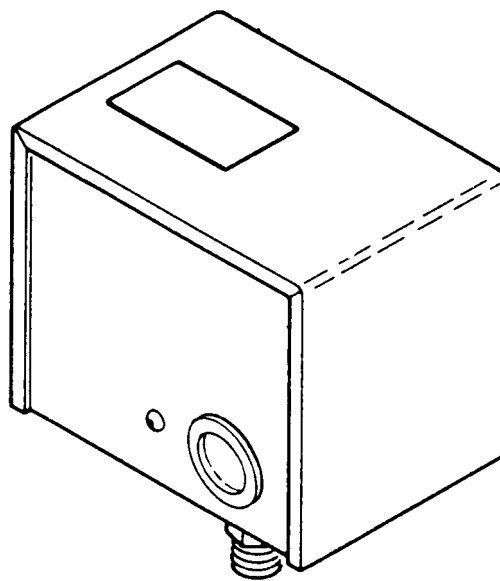
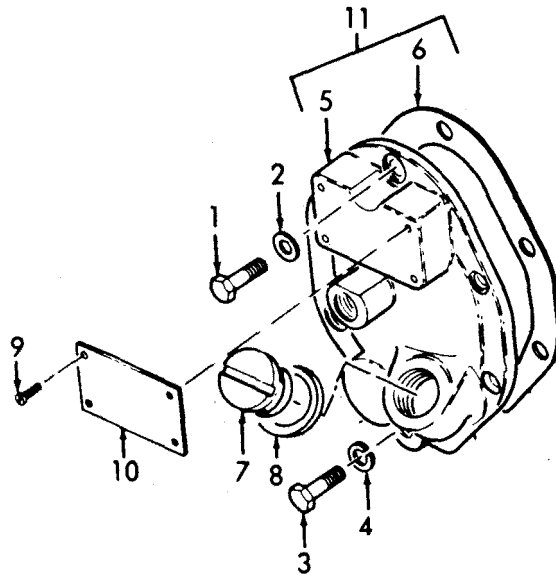


Figure 14-5. Pressure Switch.



14-9. FRAME END COVER.

- a. Removal. Refer to figure 14-6 and remove pilot valve, centrifugal unloader and frame end cover.



LEGEND FOR FIGURE 14-6:

ITEM	NSN	P/N	FSCM	QTY
1. Bolt, Machine	5306-00-225-8497	MS90725-32	96906	5
2. Washer	5310-00-637-2322	X1016T33	51436	5
3. Screw	5305-00-225-9081	MS90725-36	96906	1
4. Washer	5310-00-637-2322	X1016T33	51436	1
5. Cover		3H266703	51436	1
6. Gasket	5330-01-084-2415	3R40620	51436	1
7. Plug		3W82	51436	1
8. Packing	5330-00-250-0226	20A11CM212	30760	1
9. Stud, Drive	5307-00-047-4709	3W34427	30760	4
10. Plate, Identification		7A16X184	51436	1
11. Cover Assy.		3H26670P3	51436	1

Figure 14-6. Frame End Cover, Exploded View.

b. Cleaning and Inspection.

- (1) Clean all parts and wipe dry with a lint free cloth.
- (2) Check cover (5) for damaged threads.
- (3) Replace a deteriorated "O" ring (8).

c. Installation. Refer to figure 14-6 and install in reverse order of removal.

**14-10. AIR COMPRESSOR.**

a. Removal. Refer to paragraph 14-1 and remove the air compressor.

b. Disassembly.

- (1) Refer to figure 14-7 and remove fanwheel aftercooler and the intercooler in numerical sequence.
- (2) Refer to figure 14-6 and remove frame end cover.
- (3) Refer to figure 14-8 and remove the low-pressure cylinder, piston, rod, and rings in numerical sequence.

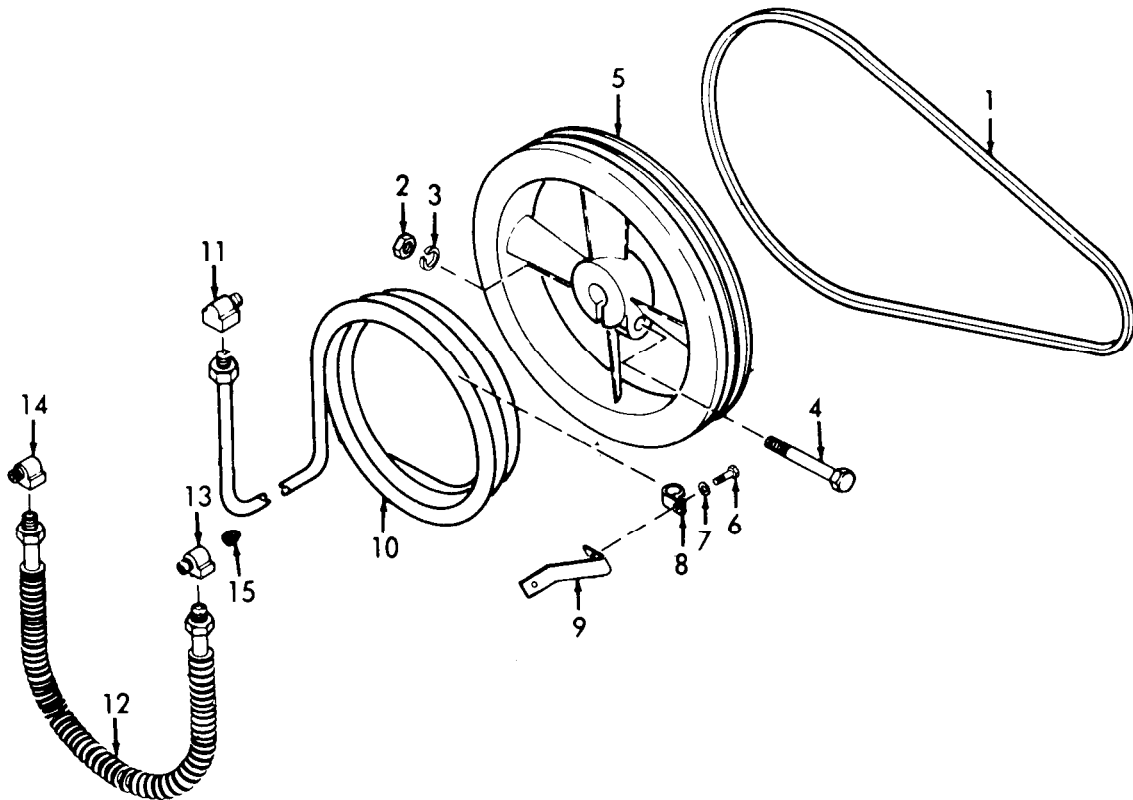


Figure 14-7. Fanwheel Aftercooler and Intercooler, Exploded View.

## LEGEND FOR FIGURE 14-7:

ITEM	NSN	P/N	FSCM	QTY
1. Belt	3030-00-215-2884	A53	24161	1
2. Nut	5310-00-768-0318	MS51967-14	96906	1
3. Washer, Lock	5310-00-543-2410	MS35338-40	96906	1
4. Screw	5305-00-071-1774	MS90725-121	96906	1
5. Fanwheel	4310-01-047-8397	3R8172	30760	1
6. Screw	5305-01-098-8943	83A2069	51436	2
7. Washer, Lock	5310-00-045-3299	MS35338-42	96906	2
8. Clamp		CW0805	51436	3
9. Brace		3R53561	51436	1
10. Tube, Aftercooler		3H48237	30760	1
11. Elbow		X15C61E8	51436	2
12. Tube, Intercooler		X1434T71	51436	1
13. Elbow		3W11282	51436	1
14. Elbow	4730-00-277-9166	402X12	79470	1
15. Plug		30A7M3	51346	1

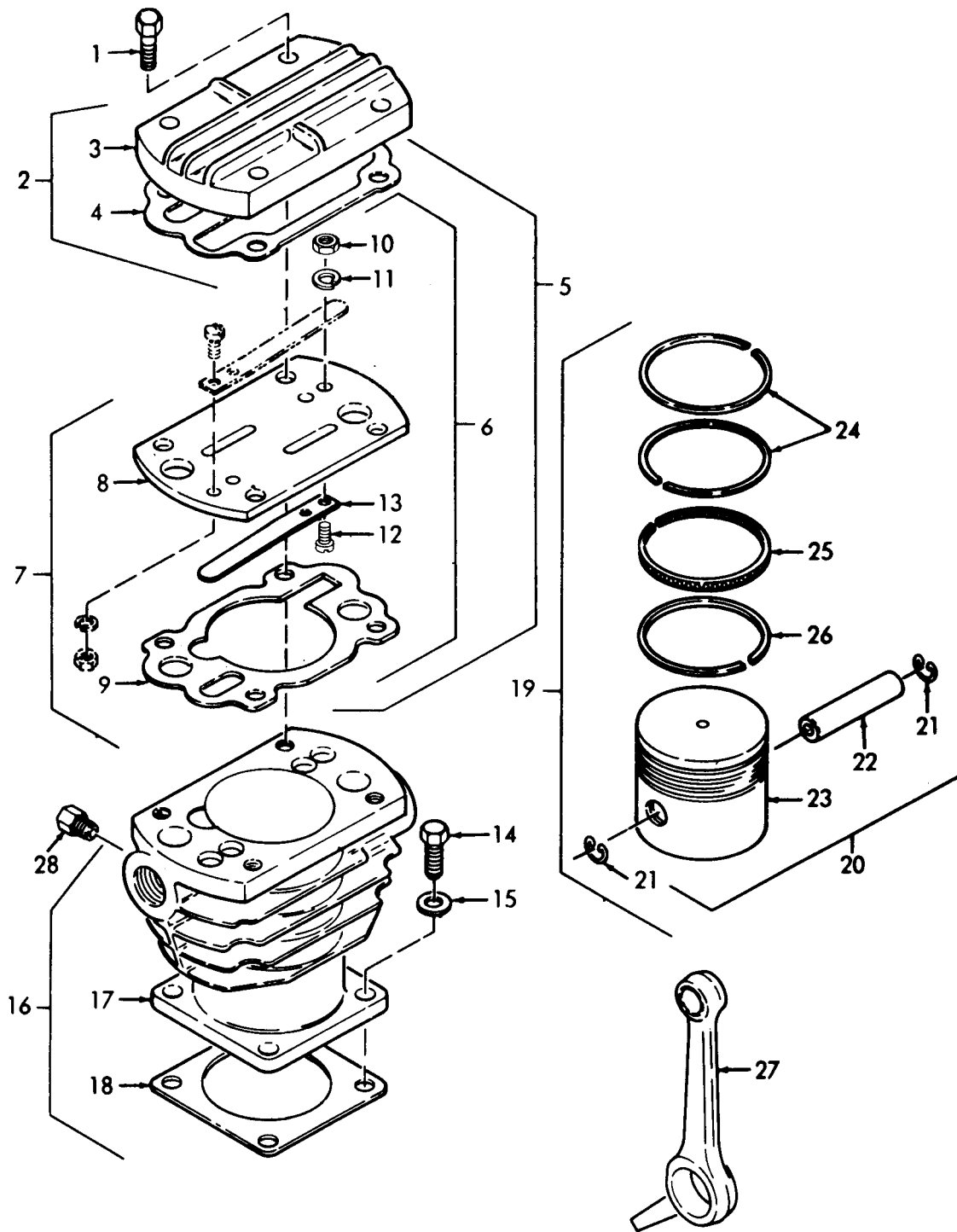


Figure 14-8. Low Pressure Cylinder Piston, Rod, and Rings, Exploded View.

(4) Refer to figure 14-9, and remove the high pressure cylinder, piston, rod, and rings in numerical sequence.

## LEGEND FOR FIGURE 14-8:

ITEM	NSN	P/N	FSCM	QTY
1.	5306-00-275-9781	35A21D117	51436	4
2. Air Head Complete		3W75302T30	51436	1
3. Head, Cylinder	4310-00-609-9199	3R4081	30760	1
4. Gasket		3W6870	51436	1
5. Spacer Valves, Gasket		3W75299T30	51436	1
6. Spacer and Valves		3W75299T30X	51436	1
7. Spacer Complete		3W75299T30S	51436	1
8. Spacer		3W6866	51436	1
9. Gasket		3W6869	51436	1
10. Nut	5310-00-761-6882	MS51967-2	96906	4
11. Washer, Lock	5310-00-582-5965	MS35338-44	96906	8
12. Screw	5305-01-015-6551	87A2X144P	51436	4
13. Valve		3W6874	51436	2
14. Screw	5305-00-269-3210	MS90725-59	96906	4
15. Washer	5310-00-205-9250	1016T34	51436	4
16. Cylinder Complete		3W75296T50	51436	1
17. Cylinder	4310-00-609-9198	3R4080	30760	1
18. Gasket		3W75330	51436	1
19. Piston and Rings	4310-00-255-0435	3W75295T20R	51436	1
20. Piston, Complete		3W75295T20	51436	1
21. Ring, Lock		3W11859	51436	1
22. Pin		3W11857	51436	1
23. Piston		D36903	51436	1
24. Piston & Ring	4310-00-869-2103	X1440TH46B	30760	2
25. Ring	4310-00-355-7685	X1440TH46M	30760	1
26. Ring	4310-00-277-2305	X1440TH46H	30760	1
27. Rod, Connecting		3H3655	51436	1
28. Connector, Tube	4730-00-091-5969	X15061C5	30760	1

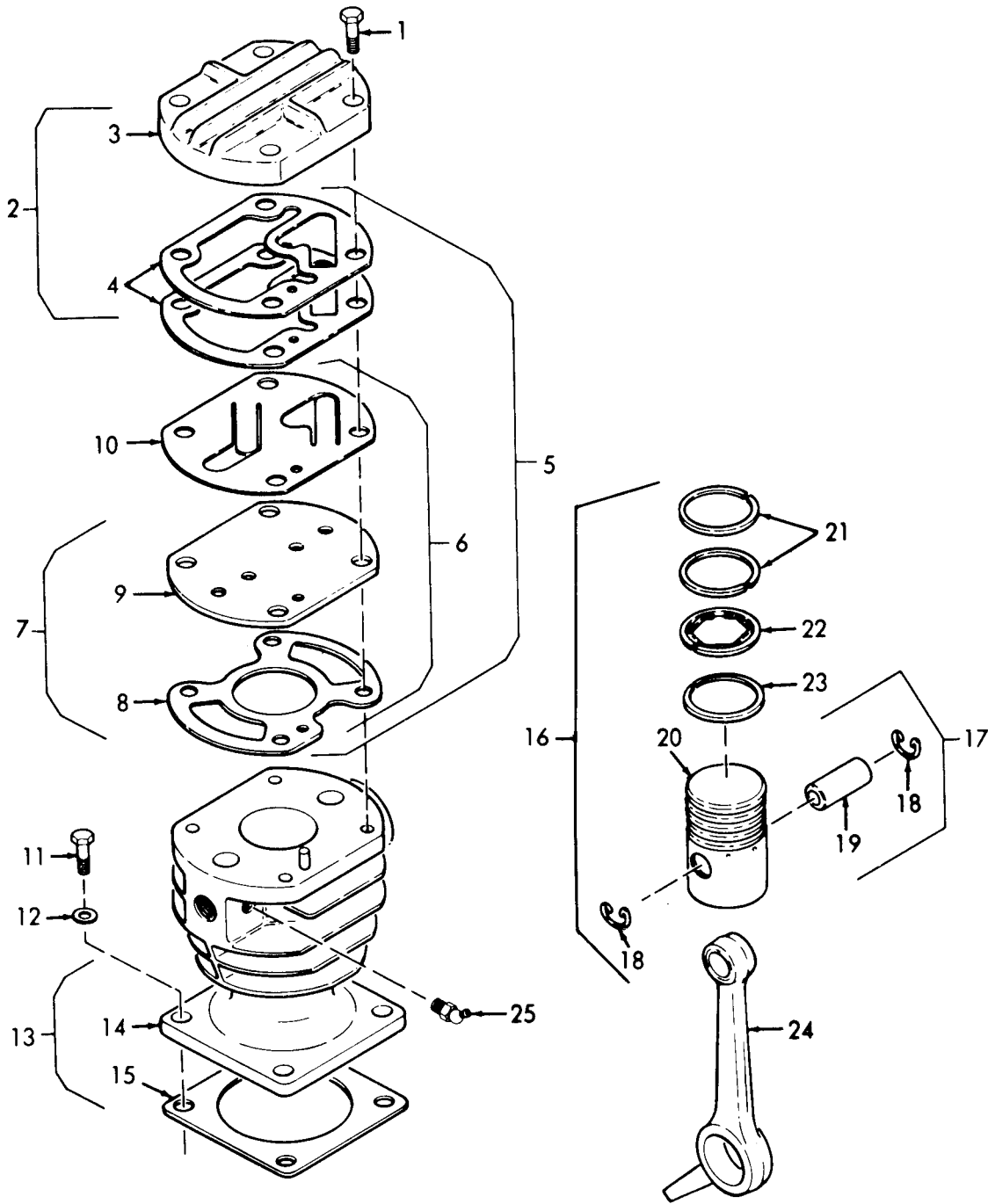


Figure 14-9. High Pressure Cylinder, Pistons, Rod, and Rings, Exploded View.

(5) Refer to figure 14-10, and remove the crankshaft assembly in numerical sequence. Do not remove decals.

## LEGEND FOR FIGURE 14-9:

ITEM	NSN	P/N	FSCM	QTY
1. Screw	5305-00-001-5115	35A2C115	51436	4
2. Air Head, Complete		3W75302T20	51436	1
3. Air Head		3W75319	51436	1
4. Gasket		3W11477	30760	2
5. Spacer, Valve, Head Gasket		3W75299T20	51436	1
6. Spacer and Valve		3W75299T20X	51436	1
7. Spacer, Complete		3W75299T20S	51436	1
8. Gasket		3W11478	51436	1
9. Spacer		3W75317	51436	1
10. Valve Plate		3W75318	51436	1
11. Screw	5305-00-269-3210	MS90725-59	96906	4
12. Washer	5310-00-205-9250	X1016T34	51436	1
13. Cylinder, Complete		3W75296T35	51436	1
14. Cylinder	4310-00-609-9197	3R4079	30760	1
15. Gasket	5330-01-023-2357	3W75330	51436	1
16. Piston and Rings	4310-00-255-0436	3W75295T10R	51436	1
17. Piston, Compress	4310-00-609-9183	3W75295T10	30760	1
18. Ring, Retaining	5365-00-448-8092	3W11859	30760	2
19. Pin, Pin	4130-00-142-0669	3W11858	30760	1
20. Piston		D36945	51436	1
21. Ring		X1440T28B	51436	2
22. Ring		X1440T28K	51436	1
23. Ring	4310-00-630-9274	X1440T28H	51436	1
24. Rod, Connecting		3H36355	51436	1
25. Plug	4730-00-288-8055	MS51884-1C	96906	1
26. Ring Set, Piston (Contains 24, 25, and 26 in Figure 14-9)		X1457T7A	51436	1

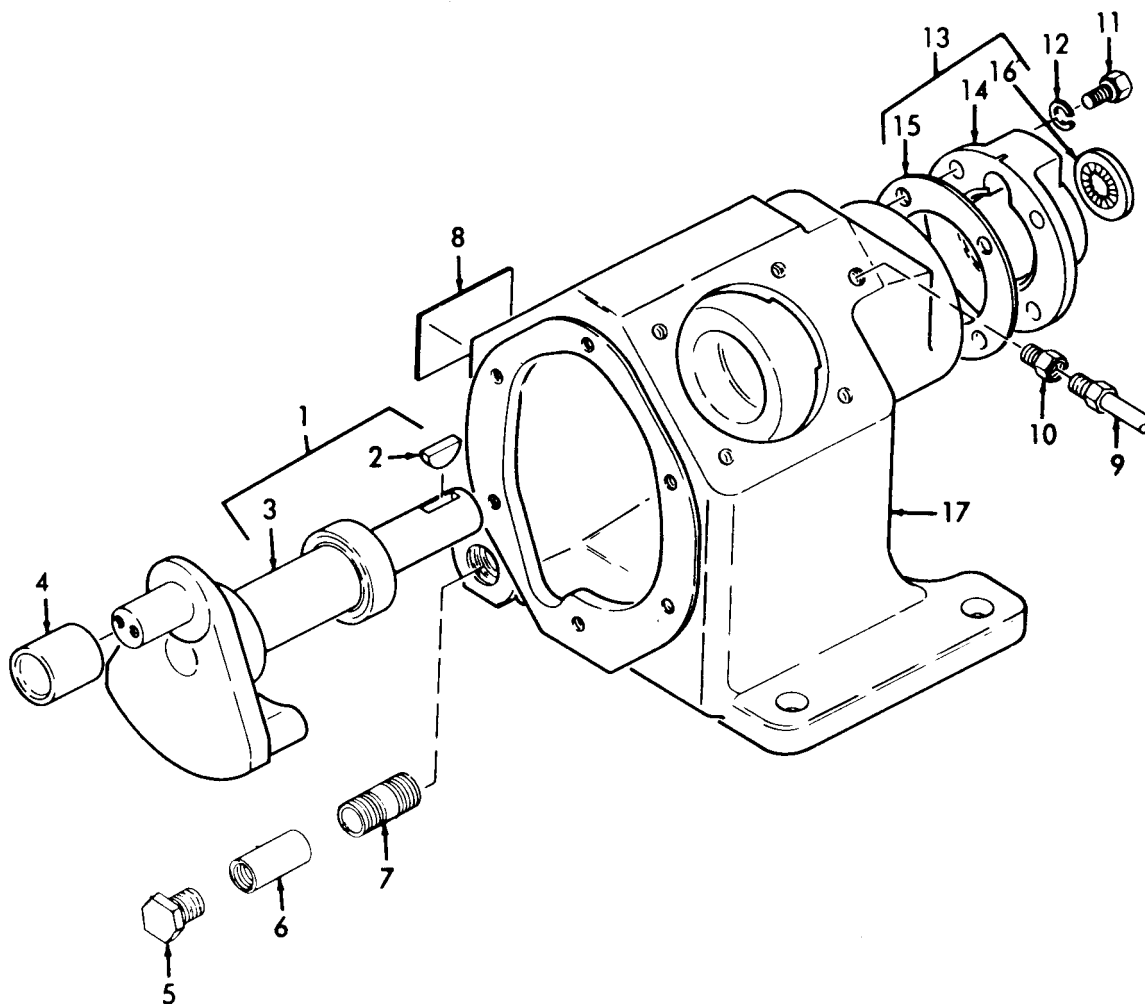


Figure 14-10. Crankshaft Assembly, Exploded View.



## LEGEND FOR FIGURE 14-10:

ITEM	NSN	P/N	FSCM	QTY
1. Crankshaft, Complete	4310-00-423-3496	3W75291T20	30760	1
2. Key	5315-00-043-1789	MS35756-38	51436	1
3. Crankshaft Assembly		3W7529DT20D	51436	1
4. Bushing, Sleeve	<del>3120-00-053-6991</del>	3W75326	88863	1
5. Plug	4730-00-091-5927	35A7B5-	30760	1
6. Coupling		11A7W4	51436	1
7. Nipple		18A7W22	51436	1
8. Decal		3W75251	51436	1
9. Breather Tube		3W75256T1	51436	1
10. Connector Tube	4730-00-091-5969	X15061C5	30760	1
11. Screw	5305-01-015-3279	35A2C56	51436	4
12. Washer	5310-00-193-9993	X1016T33	51436	4
13. Cover, Complete		3W75293T10	51436	1
14. Cover		3W6865P1	51436	1
15. Gasket	5330-00-297-5614	3W6868	30760	1
16. Seal	5330-00-240-1508	3W99622T1	51436	1
17. Frame		3F13643	30760	1

c. Cleaning, Inspection, and Repair.

- (1) Thoroughly clean the air heads by brushing or scraping lightly to remove accumulations of carbon deposits, being careful not to damage gasket surfaces. Be sure the gasket surface is free of all gasket particles.
- (2) Use solvent and wash away all accumulated oil. Be sure bore of cylinder is clean, and that all gasket particles are removed from surfaces.
- (3) Wash pistons in solvent and remove all accumulated oil or carbon. Pay particular attention to the ring grooves. Be sure that oil return holes in the oil control wiper ring grooves are open, and that grooves themselves are absolutely clean.
- (4) Inspect the cylinder bore for any signs of scoring or scuffing. If the cylinder bore shows signs of wear or scoring, as indicated by visible ridging at the end of ring travel, it must be replaced (see paragraph (6) ).
- (5) Inspect the piston for signs of scoring, or for any indication of cracked or broken lands. If these signs are found, replace the piston. If piston shows no signs of scoring, or cracked or broken lands, check the condition of ring grooves for signs of excessive wear. A tapered ring groove would result in excessive clearance, and that piston should be replaced.

**NOTE**

If new ring sets are to be installed on the pistons, and the old cylinder is going to be reused, the cylinder walls must be deglazed, or slightly roughened to provide a proper seating-in surface for the new piston rings.

- (6) Cylinders that passed inspection in paragraph (4), and are to be reused, must be deglazed as follows:
  - (a) Use a No. 80 grit abrasive cloth (NSN 5350-00-192-5047) dampened in petroleum spirits, or solvent, and move it over the surface of the bore in a rotating and reciprocating motion with a very light pressure.
  - (b) After deglazing, the cylinder wall should be thoroughly cleaned with a hot soapy solution, using a good stiff bristle (not wire) brush. Rinse thoroughly with hot water then check cleanliness of the bore by wiping with a soft white paper cloth. If the paper shows more than a slight discoloring, the cylinder has not been properly cleaned.

- (7) Wash the oil reservoir portion of the frame, being sure that accumulations of oil and sludge are removed. Clean gasket surfaces for cylinders and end covers. Be sure no particles of old gaskets remain on the surfaces.
  - (8) Clean the air valves in solvent, Clean both valve and seat by brushing with a stiff bristle (not wire) brush. Should it be necessary to scrape carbon or sludge, do so lightly, with something soft, like a square edge piece of hardwood. This will prevent marring of valve or seating surface.
  - (9) Clean thoroughly, then inspect bearings for signs of wear, or roughness. If bearings are worn, rough, or have other damage, replace the crankshaft assembly.
- d. Reassembly. Position the compressor frame (crankcase) on workbench. Fasten it down so it will not tip over when weight is added by assembly.

**NOTE**

Install new gaskets in all positions at reassembly, and a new oil seal in the shaft end cover.

**NOTE**

Refer to figure 14-10 for steps (1) through (3).

- (1) Install the crankshaft, complete (1, figure 14-10 ) from frame end as follows:
  - (a) Remove the retaining ring from groove at outer end bearing (near threaded end of shaft) then insert shaft into the frame.
  - (b) Guide threaded end through housing until bearings reach their position, then tap gently with a soft hammer on the journal end of shaft until the empty retaining ring groove extends approximately 1/16-inch out of housing.
  - (c) Insert retaining ring in its groove, then tap the threaded end of shaft gently with a soft hammer, until the retaining ring is tight against the housing.

**CAUTION**

Install oil seal with the sealing lip facing inside of the shaft end cover, then press into position. If a vise is used to press the seal, be sure serrated jaws, if any, are covered to protect seal from distortion.

- (2) Install the shaft end oil seal (16) in cover (14).

**CAUTION**

Protect lip of the seal from cutting by the threads on end of crankshaft by wrapping a sheet of 0.003 inch brass shim stock around threads, then slipping shaft end cover and seal into position on frame.

- (3) Place gasket (15) in position around shaft, then install shaft end cover and seal as described in caution above. Secure cover with four steel washers (12) and capscrews (11). Install connector tube (10) and breather tube (9) in frame (17), then install nipple (7), coupling (6), and plug (5).

**NOTE**

Refer to figure 14-9 for steps (4) through (9).

- (4) Install connector (25, figure 14-9) and connecting rod (24). Check clearance between crankpin bushing and connecting rod. It should be between 0.001 and 0.002 inch. If clearance is 0.0025 inch replace bushing and connecting rod.
- (5) Measure the clearance between piston pin (19) and piston (20). This is a very close tolerance. It should be between 0.0003 inch and 0.0009 inch. If clearance is as much as 0.0012 inch replace pin and piston. Install pin (19) through rod (24) and piston (20), and secure with the lockrings (18).

**NOTE**

Place piston rings in cylinder bore to measure end gap before installation in ring grooves. Also measure piston to bore clearance. If ring end gap is between 0.005 and 0.015 inch, they are satisfactory. If piston clearance in bore of high pressure cylinder (1-3/4 inch dia.) is between 0.0025 and 0.0035 inch the clearance is satisfactory. Piston pin to connecting rod clearance should be between 0.0002 and 0.0007 inch. If in range, they are satisfactory.

- (6) Before installing rings, see that all ring grooves are lubricated with compressor lubricating oil.
- (7) Install ring (23) in bottom groove of piston (20). Install the expander in groove first, before ring (22), in the second groove from bottom of piston, then install ring (21) in the second groove from top, and the top groove of piston (20). Turn end gaps of ring until they are staggered at 90° to each other.

- (8) Position cylinder gasket (15) on frame, then position cylinder (14) over piston (20) and press in on rings until they slip into the tapered bottom of the cylinder. It is recommended that a ring compressor be used at this time to avoid distorting or breaking the rings. Seat cylinder on gasket, then install steel washer (12) and capscrew (11).
- (9) Install gasket (8), spacer (9) and valve plate (10). Install two gaskets (4) and air head (3), then install capscrews (1) and tighten.

#### NOTE

Refer to figure 14-8 for steps (10) through (13).

- (10) Install connecting rod (27, figure 14-8) on crankshaft crank pin bushing. Check that clearance is between 0.001 and 0.002 inch. After checking clearance between pin (22 and rod 27), for a close tolerance of between 0.0002 and 0.0007 inch. If satisfactory install pin (22) through rod (27) and piston (23), then secure pin with lockrings (21).
- (11) Fill oil ring grooves of piston (23) with compressor lubricating oil. Place ring set in cylinder (17) bore, then measure end gap. It should measure between 0.005 and 0.015 inch. If satisfactory, install ring (26) in bottom groove of piston (23). Install ring (25) in the second groove from the bottom. Install one ring (24) in the second groove from the top, and the other ring (24) in the top groove. Turn end gaps of rings until they are staggered at 90° to each other.
- (12) Lubricate bore of cylinder (17); position gasket (18) over rod (27) to fit on frame. Position cylinder (17) over piston and rings, press in on rings until they slip into the tapered skirt of the bore. It is recommended that a ring compressor be used for this purpose to avoid distorting or breaking the rings. Install steel washers (15) and capscrews (14).
- (13) Install valves (13) and secure with fillister head screws (12), lockwashers (11), and nuts (10). Install gasket (9), spacer and valves complete (6), gasket (4), and air head (3). Secure with four capscrews (1). Install connector (28) in cylinder (17).

#### NOTE

Refer to figure 14-7 for steps (14, 15, and 16).

- (14) Install elbows (13 and 14, figure 14-7), in cylinders. Install pipe plug in elbow (14), then install intercooler tube (12) in elbows (13 and 14).
- (15) Install two elbows (11). Install aftercooler tube (10) in elbows (11). Install three clamps (8) and brace (9) on aftercooler (10) and secure with internal lockwashers (7) and capscrew (6).

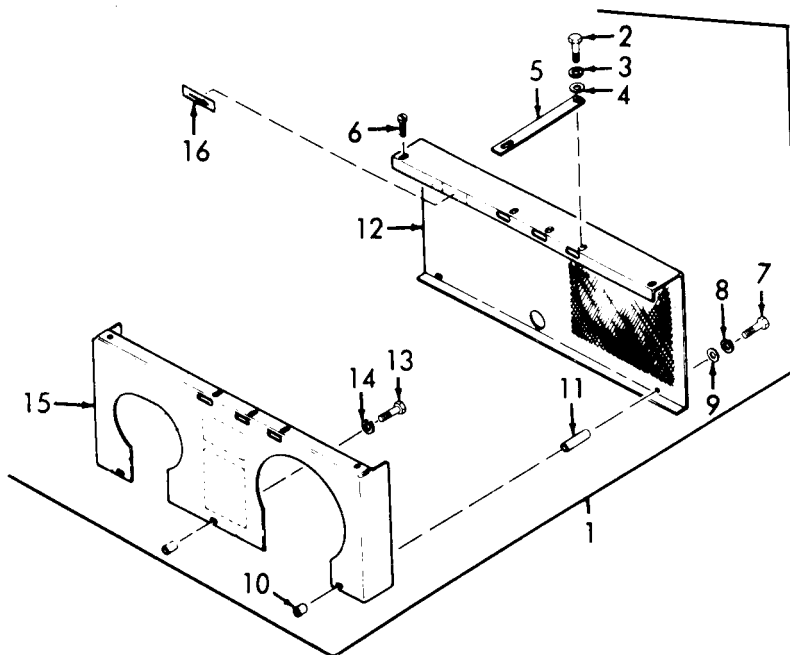
(16) Install fanwheel (5) on crankshaft and secure with capscrew (4), lockwasher (3), and nut (2).

e. Installation. Refer to paragraph 14-2 and install the air compressor.

**14-11. BELT GUARD ASSEMBLY.**

a. Removal. Remove the belt guard as illustrated in figure 14-11.

b. Installation. Install the belt guard as illustrated in figure 14-11.



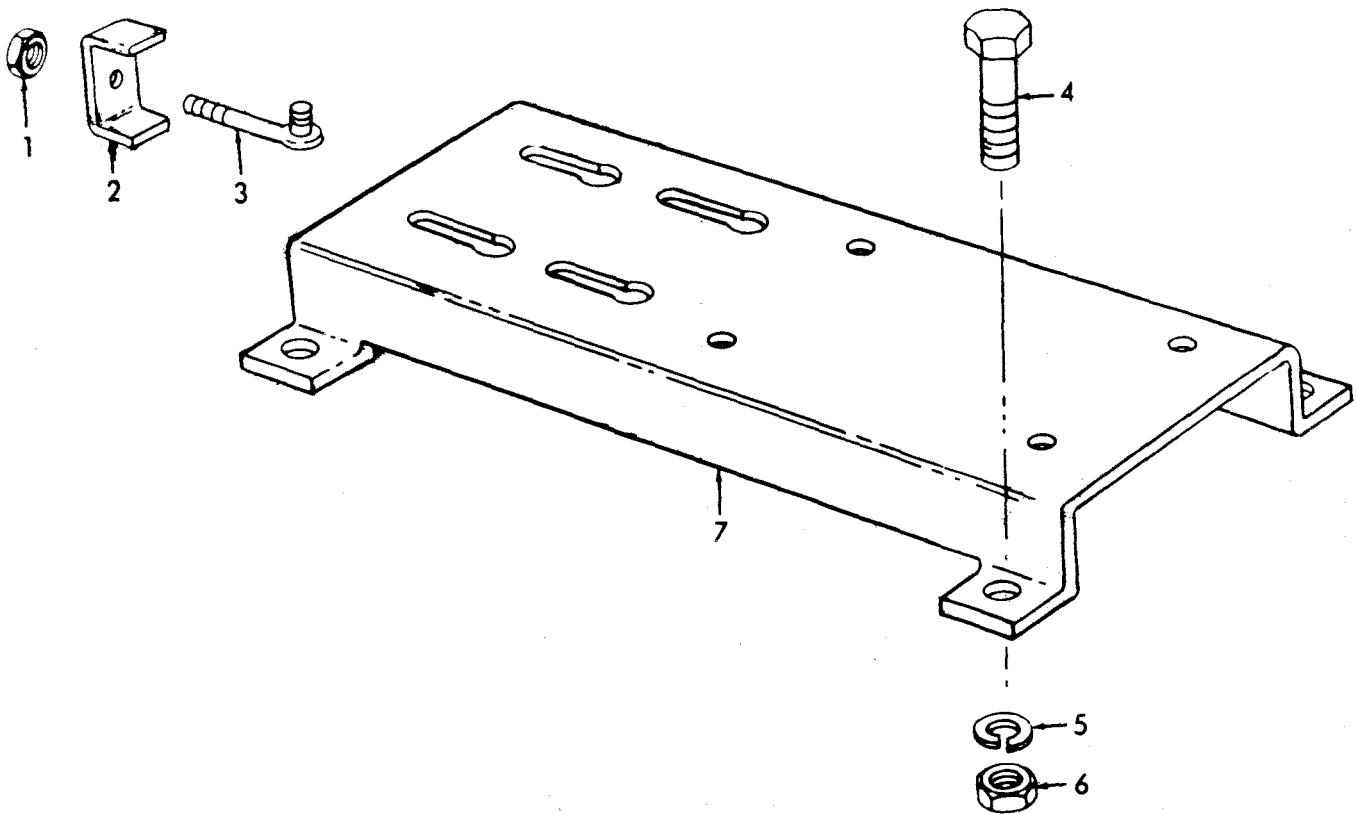
LEGEND FOR FIGURE 14-11:

ITEM	NSN	P/N	FSCM	QTY
1. Belt, Guard Assy.		3W75478T63E	51436	1
2. Screw, Cap	5305-00-269-3214	MS90725-64	96906	1
3. Washer, Lock	5310-00-637-9541	MS35338-46	96906	1
4. Washer, Flat	5310-00-950-1310	MS27183-4	96906	1
5. Brace		3W75424T3	51436	1
6. Screw, Thread	5305-00-052-6920	MS24629-56	96906	2
7. Screw, Cap	5305-01-065-6901	35A2C132	30760	2
8. Washer, Lock	5310-00-637-9541	14A5C76	10458	2
9. Washer, Flat	5310-00-080-6004	12A5C4	51436	2
10. Spacer	5365-01-062-3632	3W75479T4	51436	3
11. Spacer	5365-01-062-2840	3W75479T13	51436	2
12. Guard, Belt		R57114	51436	1
13. Screw, Cap	5305-00-001-5115	35A2C115	30760	1
14. Washer, Lock	5310-00-637-9541	14A5C76	10458	1
15. Guard, Belt, Back		H37745	51436	1
16. Arrow, Direction		3W45928	51436	1

Figure 14-11. Belt Guard Assembly, Removal and Installation.

**14-12. BELT TIGHTENER AND BASE ASSEMBLY.**

- a. Removal. Remove the belt tightener and base as illustrated in figure 14-12.
- b. Installation. Install the belt tightener and base as illustrated by figure 14-12.



**LEGEND FOR FIGURE 14-12:**

ITEM	NSN	P/N	FSCM	QTY
1. Nut, Bolt, Tight.	5310-01-015-0598	Y6A4C5	51436	1
2. Clamp, Belt Tight.	4310-00-216-7851	3W11261	30760	1
3. Tightener, Belt		X1429 TX520X6	51436	1
4. Screw, Cap	5305-00-269-3211	MS90725-60	96906	4
5. Washer, Lock	5310-00-543-5101	MS35338-27	96906	4
6. Nut, Plain	5310-00-768-0318	MS51967-14	96906	4
7. Base Assy.		3R57116	51436	1

Figure 14-12. Belt Tightener and Base Assembly, Removal and Installation.





## CHAPTER 15

### MAINTENANCE OF BODY COMPONENTS

---

#### 15-1. DOORS AND HINGES.

- a. General. The side and rear doors should not be removed unless absolutely necessary. In most cases, repairs can be made with the doors installed.
- b. Removal. Support the door to prevent damage prior to removing hardware. Remove the doors as illustrated by figures 15-1 and 15-2.
- c. Cleaning, Inspection, and Repair.
  - (1) Clean doors with approved cleaning solvent and dry thoroughly.
  - (2) Inspect doors for cracks, breaks, dust, rust, and other damage or defects,
  - (3) Break rivets if necessary to make repairs. Straighten bends, weld cracks and breaks. Replace defective hinges.
- d. Installation. Install the doors as illustrated by figures 15-1 and 15-2.

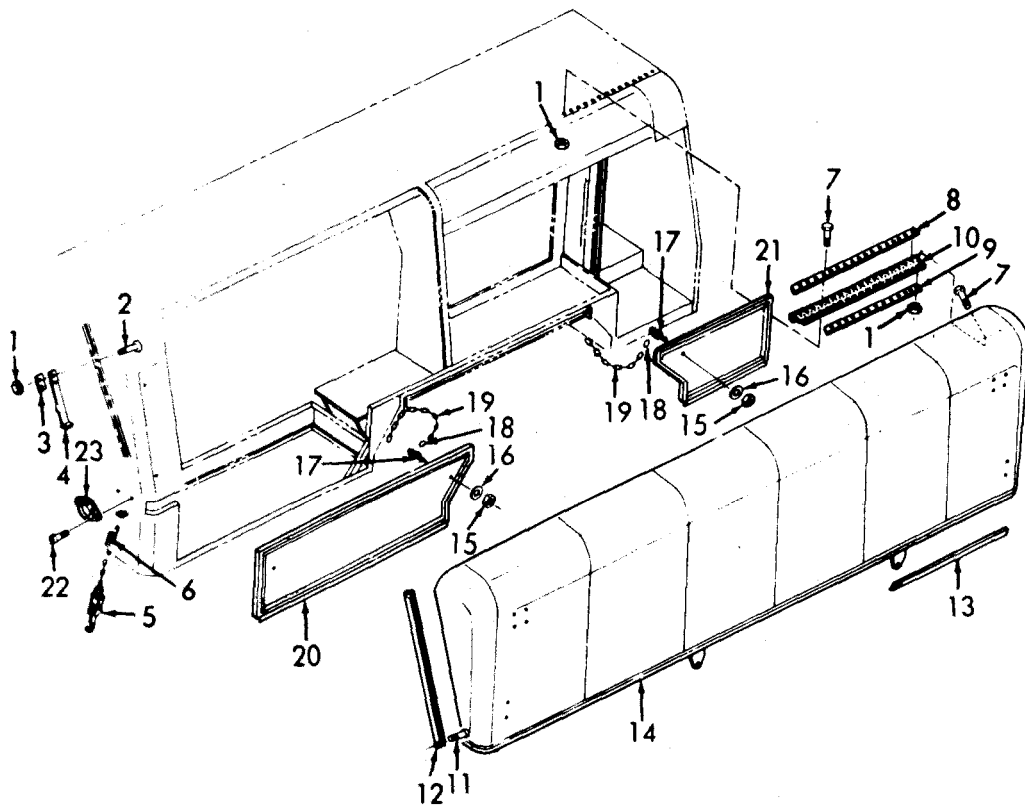


Figure 15-1. Side Doors, Removal and Installation,

LEGEND FOR FIGURE 15-1:

ITEM	NSN	P/N	FSCM	QTY
1. Nut, Self-Locking	5310-00-088-1251	MS51922-1	96906	311
2. Screw, Cap	5305-00-068-0500	MS90725-3	96906	2
3. Retainer, Clip		13217E1149	59678	4
4. Bracket, Dble Angle	5340-00-223-3899	13217E1150	59678	2
5. Clamp, Toggle Van		13217E1021	97403	6
6. Spring, Helical	5360-00-223-3864	13217E1174	59678	6
7. Screw, Cap	5305-00-068-0502	MS90725-6	96906	295
8. Retainer, Gasket	2510-00-349-8937	13217E1044-2	59678	2
9. Retainer, Gasket	2510-00-349-8900	13217E1044-3	59678	2
10. Gasket	5330-00-250-9598	13217E1151-2	59678	38
11. Rivet	5320-00-003-6954	13217E1157	59678	4
12. Support, Canopy		13217E1048	59678	4
13. Gasket		13217E1045	59678	1
14. Canopy, Assy, LH		13217E0992	59678	1
14. Canopy, Assy, RH		13217E0993	59678	1
15. Nut, Self-Locking	5310-00-087-4652	MS51922-17	96906	9
16. Washer, Flat	5310-00-080-6004	MS27183-14	96906	4
17. Connector, Rod		13217E1173	59678	11
18. Link, Chain	4010-00-543-4559	13218E0010-6	97403	5
19. Chain		13218E0028-2	97403	104
20. Door, Bottom, LH		13217E0982	59678	1
20. Door, Fwd, RH		13217E0981	59678	1
21. Door, Rear, LH		13217E0984	59678	1
21. Door, Rear, RH		13217E0983	59678	1
22. Rivet	5320-00-824-5908	MS20470AD7-7	59678	4
23. Reflector, Amber	5905-00-202-3639	MS353870-2	96906	2

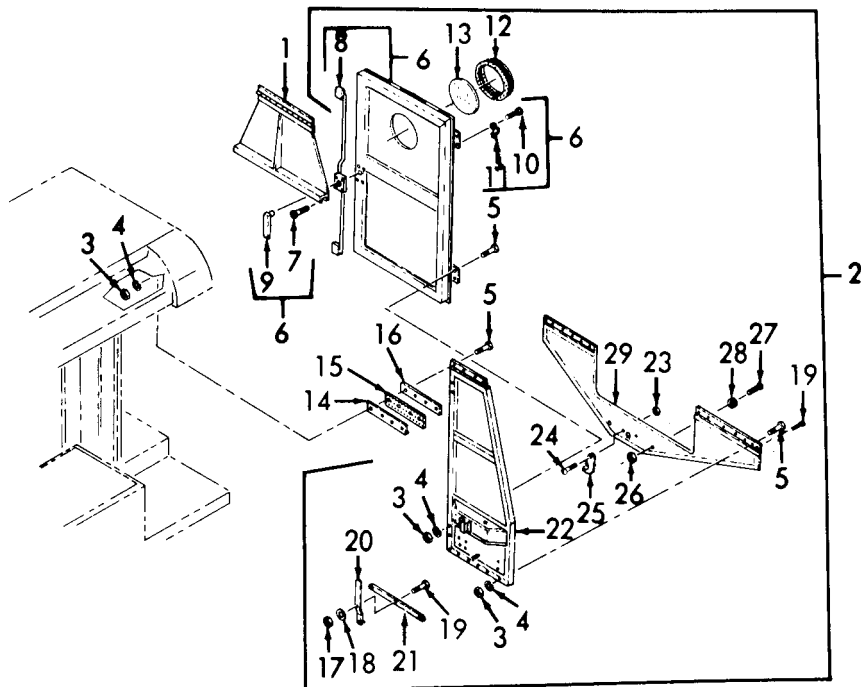


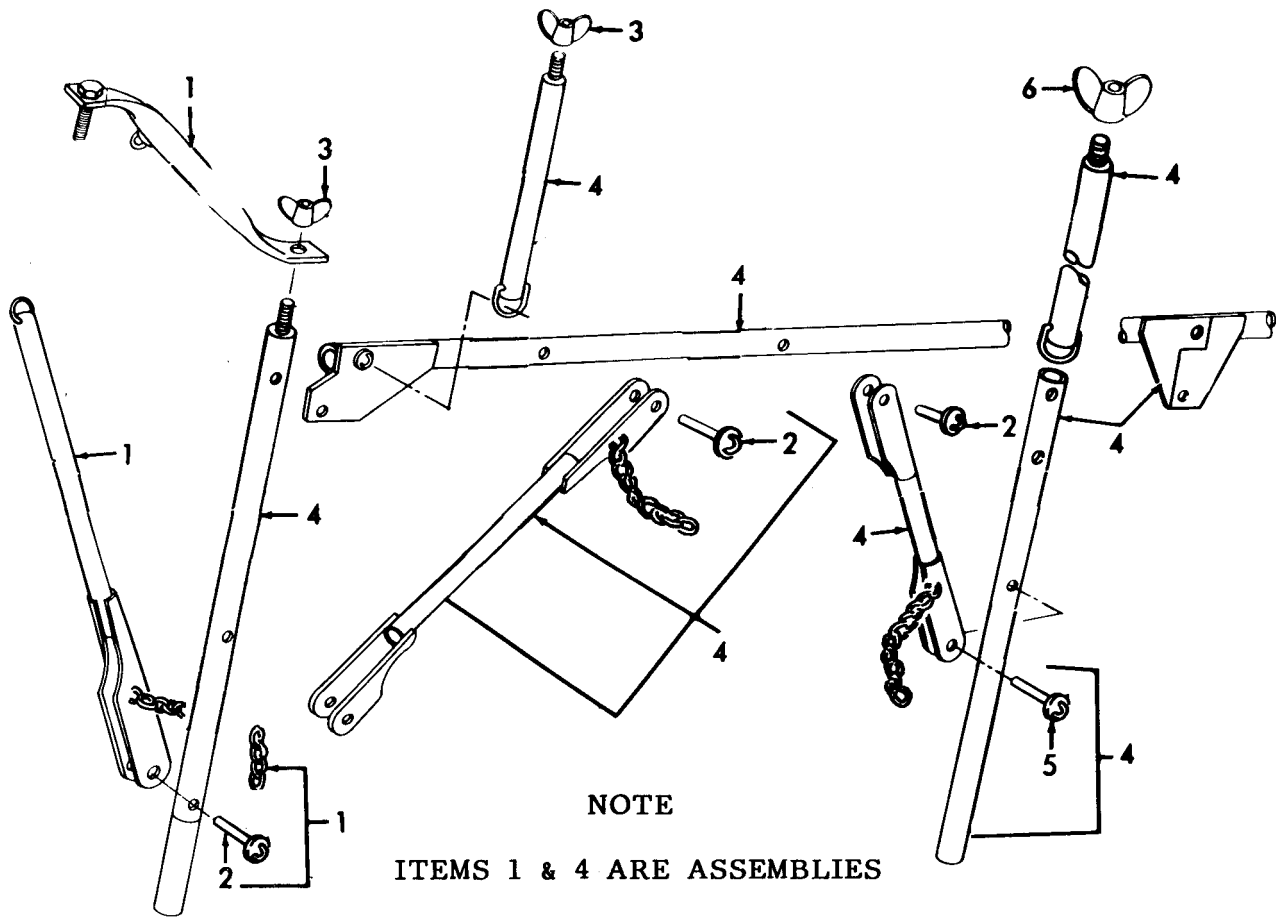
Figure 15-2. Rear Door and Panel, Removal and Installation.

## LEGEND FOR FIGURE 15-2:

ITEM	NSN	P/N	FSCM	QTY
1. Panel, Top		13217E0987	59678	1
2. Door Assy.		13217E0990	59678	1
3. Nut, Plain	5310-00-761-6882	MS51967-2	96906	5
4. Washer, Lock	5310-00-582-5965	MS35338-44	96906	12
5. Screw, Cap	5305-00-071-2510	MS90725-13	96906	6
6. Door, Rear		13217E0989	59678	1
7. Screw, Tapping	5305-00-432-4202	MS51861-46	96906	8
8. Latch Assy.		13217E1024	59678	1
9. Handle, Door		SW2553P4	98255	1
10. Screw, Tapping	5305-00-432-4164	MS51861-25	96906	2
11. Clip, Padlock	5340-00-434-4364	13217E1234	97403	1
12. Gasket, Rear	2510-00-993-7462	13217E1028	97403	1
13. Glass, Rear Door		SW2700P1	98255	1
14. Retainer, Gasket		13217E1153	59678	2
15. Gasket	5330-00-400-9523	13217E1151-1	59678	2
16. Retainer, Gasket		13217E1044-3	59678	2
17. Nut, Self-Locking	5310-00-088-1251	MS51922-1	96906	311
18. Washer, Flat	5310-00-809-4058	MS27183-10	96906	10
19. Screw	5305-00-068-0502	MS90725-6	96906	12
20. Latch, Hand		13217E1015	59678	2
21. Rod, Lock	4940-00-349-8897	13217E1016	59678	2
22. Panel Assy, LH		13217E0986	59678	1
22. Panel Assy, RH		13217E0985	59678	1
23. Nut, Self-Locking	5310-00-208-4026	MS20500-1032	96906	9
24. Screw, Machine	5305-00-993-1848	MS35207-265	96906	1
25. Hook, Rear		13217E1078	59678	1
26. Nut, Self-Locking	5310-00-925-9645	MS21083N04	96906	14
27. Screw, Machine	5305-00-889-2999	MS35206-217	96906	2
28. Bumper		13217E1077	59678	2
29. Panel, Rear		13217E0988	59678	1

**15-2 TENT FRAME.**

- a. Removal. Remove the tent frame as illustrated by figure 15-3.
- b. Cleaning, Inspection, and Repair.
  - (1) Clean all parts with cleaning solvent and dry thoroughly.
  - (2) Inspect all parts for bends, cracks, and other defects.
  - (3) Weld cracks. If a bent pipe in the tent frame cannot be straightened, cut bent section out and weld in a piece of pipe of the same length and diameter.
- c. Installation. Install the tent frame as illustrated by figure 15-3.



LEGEND FOR FIGURE 15-3:

ITEM	NSN	P/N	FSCM	QTY
1. Frame, Curtain		13217E0972	59678	2
2. Pin	5340-01-049-0159	MS17990C621	96906	1
3. Nut, Plain	5310-00-543-4717	MS35425-28	96906	12
4. Frame, Curtain		13217E0971	59678	2
5. Pin	5340-01-049-4252	MS17990C624	96906	1
6. Nut, Wing	5310-00-274-9337	MS35425-36	96906	4

Figure 15-3. Tent Frame, Removal and Installation.

**15.3. UTILITY LADDERS.**

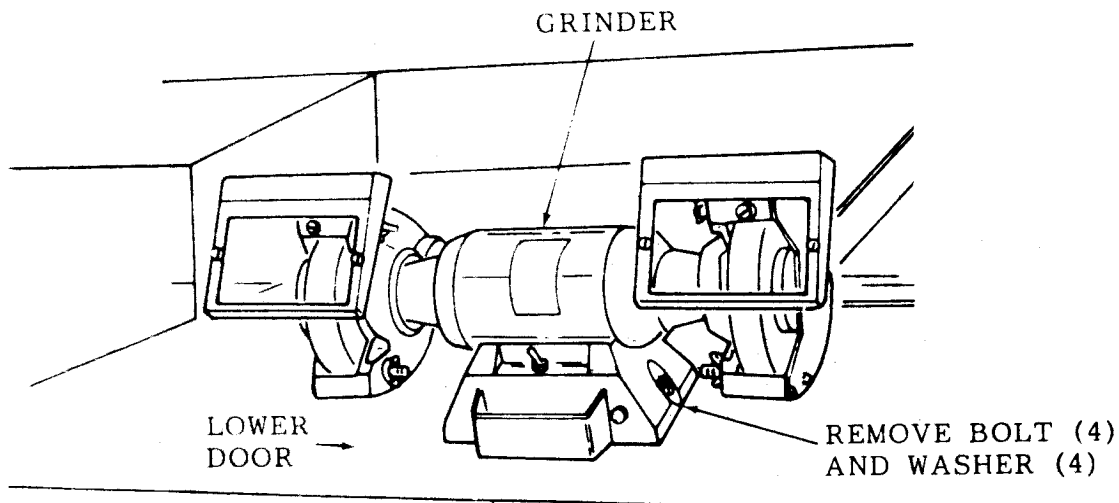
- a. Removal. Remove the two ladders from their stowed positions, inside the shop set on both sides at the rear.
- b. Cleaning and Inspection.
  - (1) Clean ladders with cleaning solvent and dry thoroughly.
  - (2) Inspect for damage or defects and replace a defective ladder.
- c. Installation. Install the utility ladders in their respective stowed positions, as removed. Secure the two ladders with their retaining straps so they will remain in place while in transit.

**15-4. DOOR SEALS.**

- a. Cleaning and Inspection. Inspect all door seals for cracks, tears, deterioration, and water or dust leakage. Clean seals with soapy water and dry thoroughly. Wipe the seals with a silicone compound.
- b. Testing. If water or dust leakage occurs around seals, darken the interior of the van body to test for light leaks. Manipulate the seals to prevent light leakage. Use cellular rubber (sponge) blocks under the lip of any seal that has become depressed and permits light.

**15-5. GRINDER.**

- a. Removal. Remove the grinder as illustrated in figure 15-4.
- b. Installation. Install the grinder as illustrated in figure 15-4.



NOTE: TAG AND DISCONNECT ELECTRICAL LEADS.

Figure 15-4. Grinder, Removal and Installation.

**15-6. MILLING AND GRINDING ATTACHMENT.**

- a. Removal. Remove two nuts and washers (fig. 15-5), and remove milling and grinding attachment from panel.
- b. Installation. Place the milling and grinding attachment on the panel (fig. 15-5), and secure with the two nuts and washers.

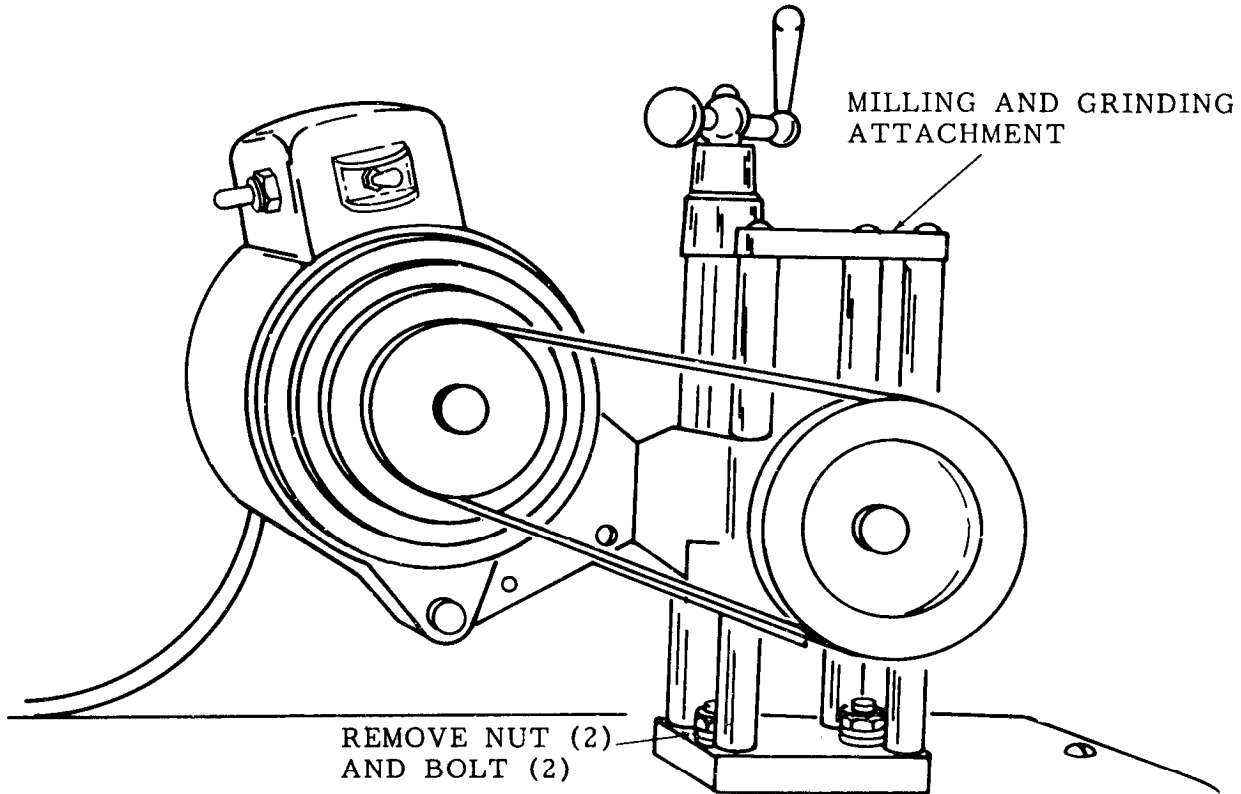


Figure 15-5. Milling and Grinding Attachment, Removal and Installation.

**15-7. VALVE REFACER.**

- a. Removal. Remove valve refacer as illustrated in figure 15-6.
- b. Installation. Install the valve refacer as illustrated in figure 15-6.

**15-8. 17½-TON PRESS FRAME.**

- a. Removal. Remove the press frame as illustrated in figure 15-7.
- b. Installation. Install the press frame as illustrated in figure 15-7.

**15-9. DRILLING MACHINE.**

- a. Removal. Remove the drilling machine as illustrated in figure 15-8.
- b. Installation. Install the drilling machine as illustrated in figure 15-8.

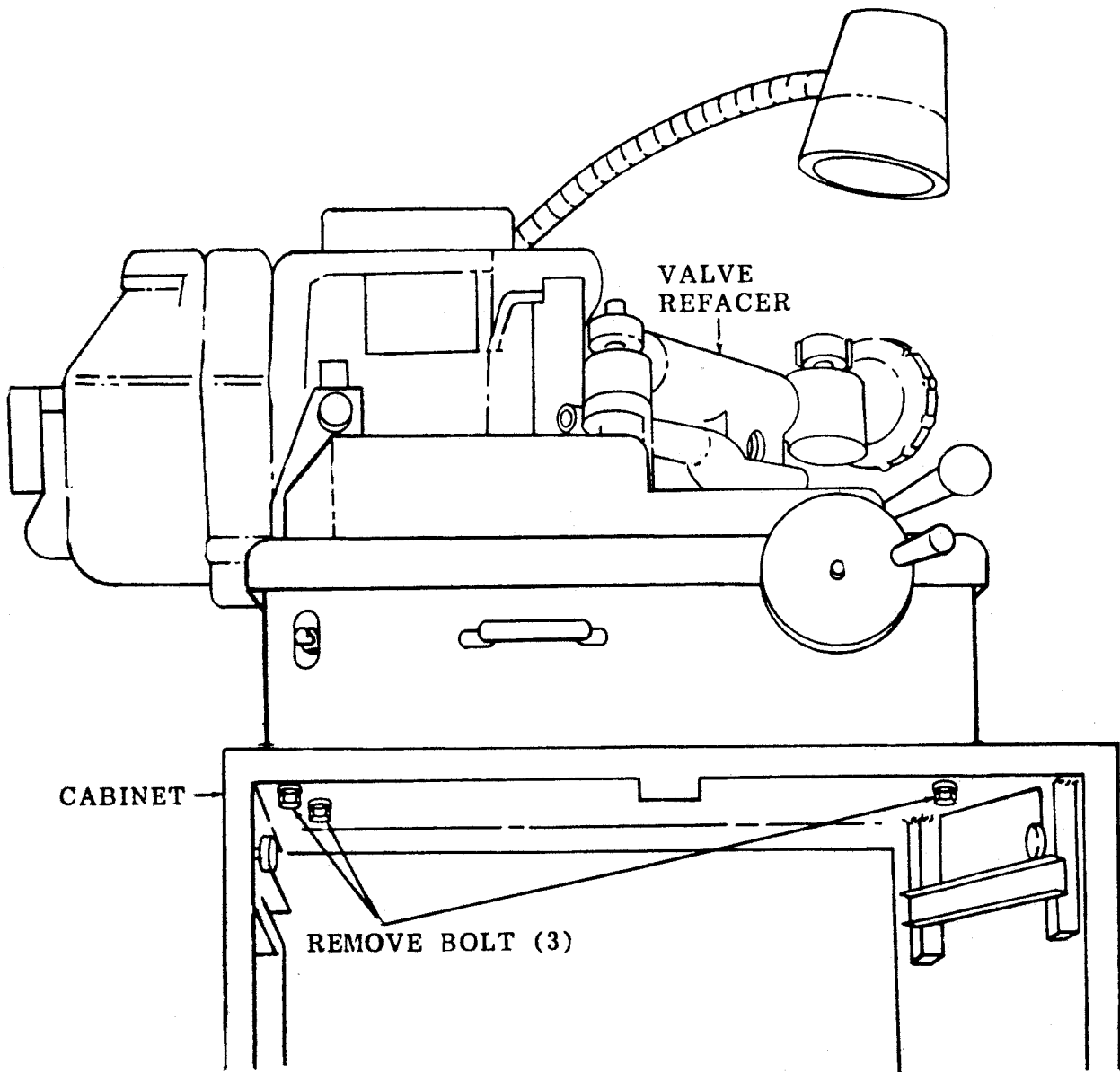


Figure 15-6. Valve Refacer, Removal and Installation.

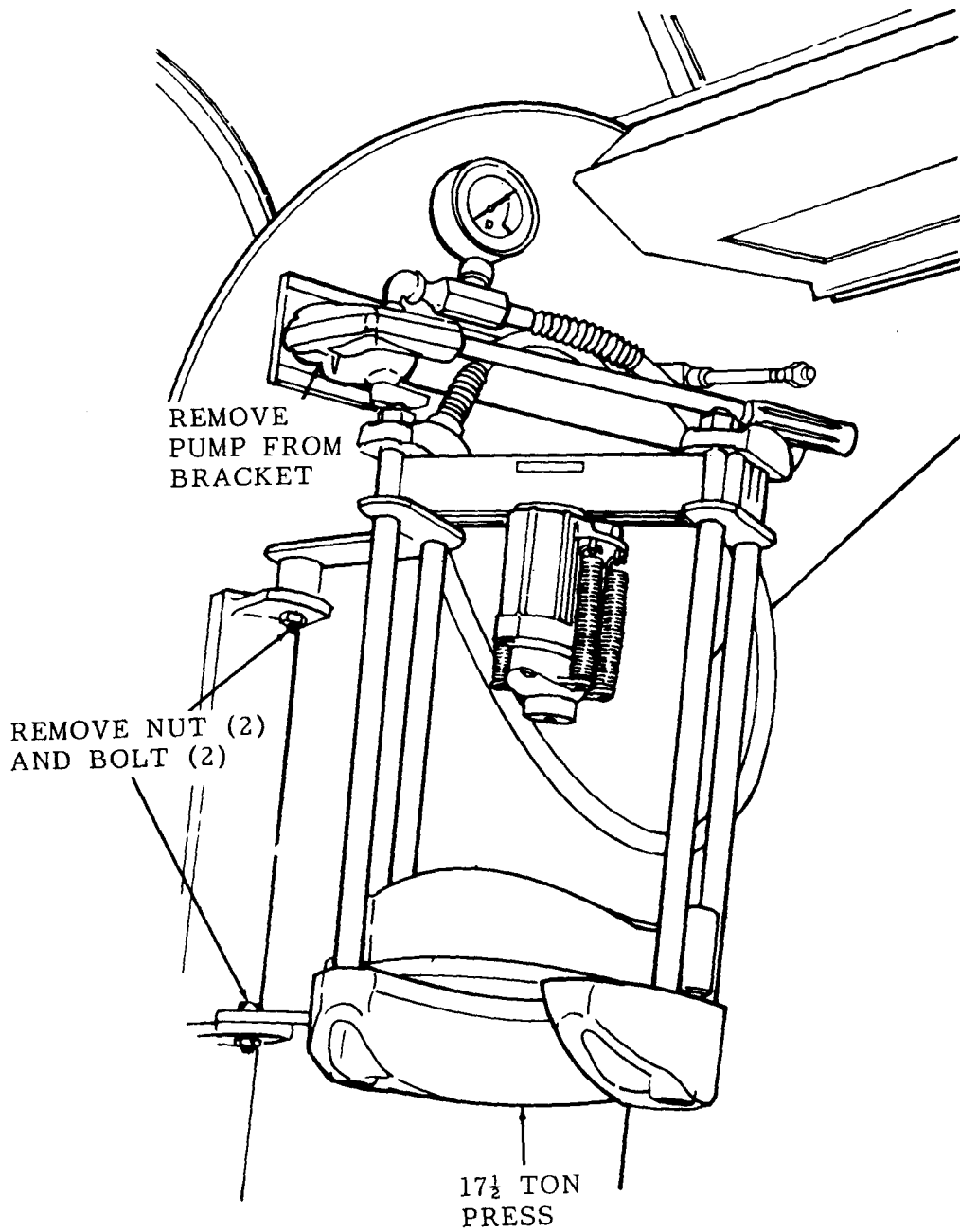


Figure 15-7. 17½-Ton Press Frame, Removal and Installation.



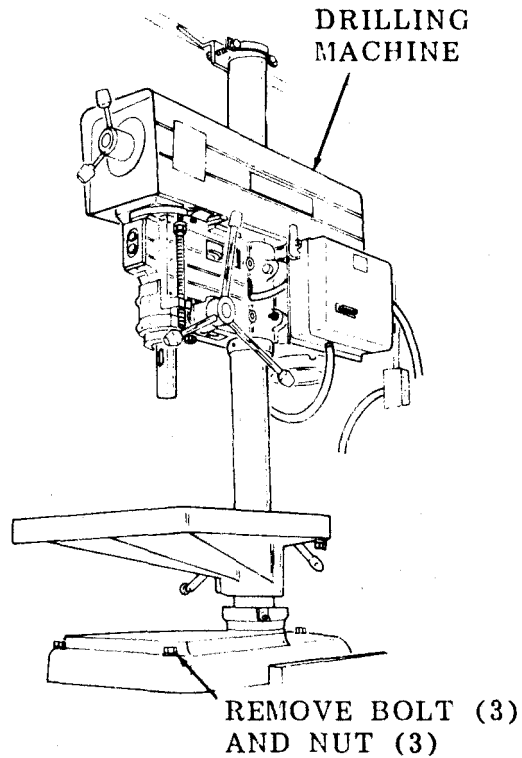


Figure 15-8. Drilling Machine, Removal and installation.

**15-10. VISE,**

- a. Removal. Remove the vise as illustrated in figure 15-9.
- b. Installation. Install the vise as illustrated in figure 15-9.

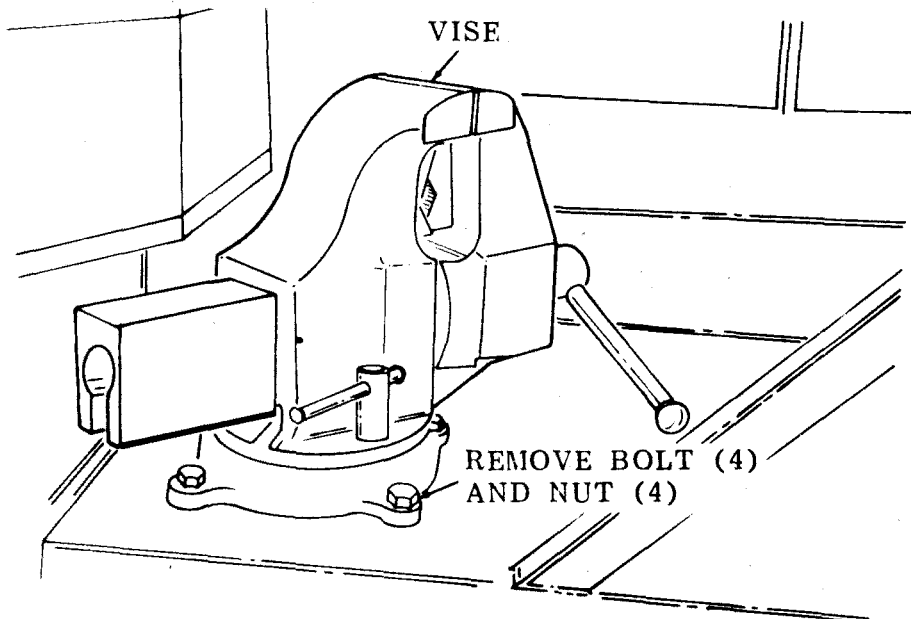


Figure 15-9. Vise, Removal and Installation.

15-11. LATHE BELT.

a. Removal.

- (1) Loosen the knob on the gear box and open door.
- (2) Loosen four bolts (fig. 15-10) and remove belt.

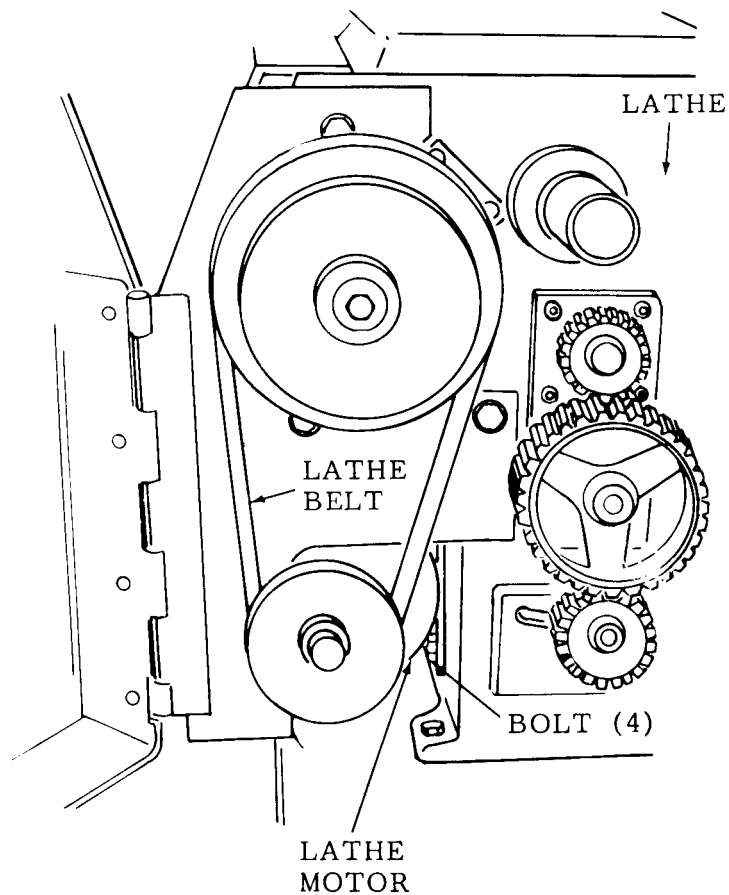


Figure 15-10. Lathe Belt, Removal and Installation.

- b. Installation. Install the lathe belt as illustrated in figure 15-10.
- c. Belt Adjustment. Apply downward pressure on the motor to give belt a  $\frac{1}{2}$ -inch deflection midway between the pulleys and tighten four bolts .

**15-12. LATHE.**

- a. Removal. Remove the lathe as illustrated in figure 15-11.
- b. Installation. Install the lathe as illustrated in figure 15-11.

**15-13. LATHE STAND.**

- a. Removal. Remove the lathe stand as illustrated by figure 15-12.
- b. Installation. Install the lathe stand as illustrated by figure 15-12.

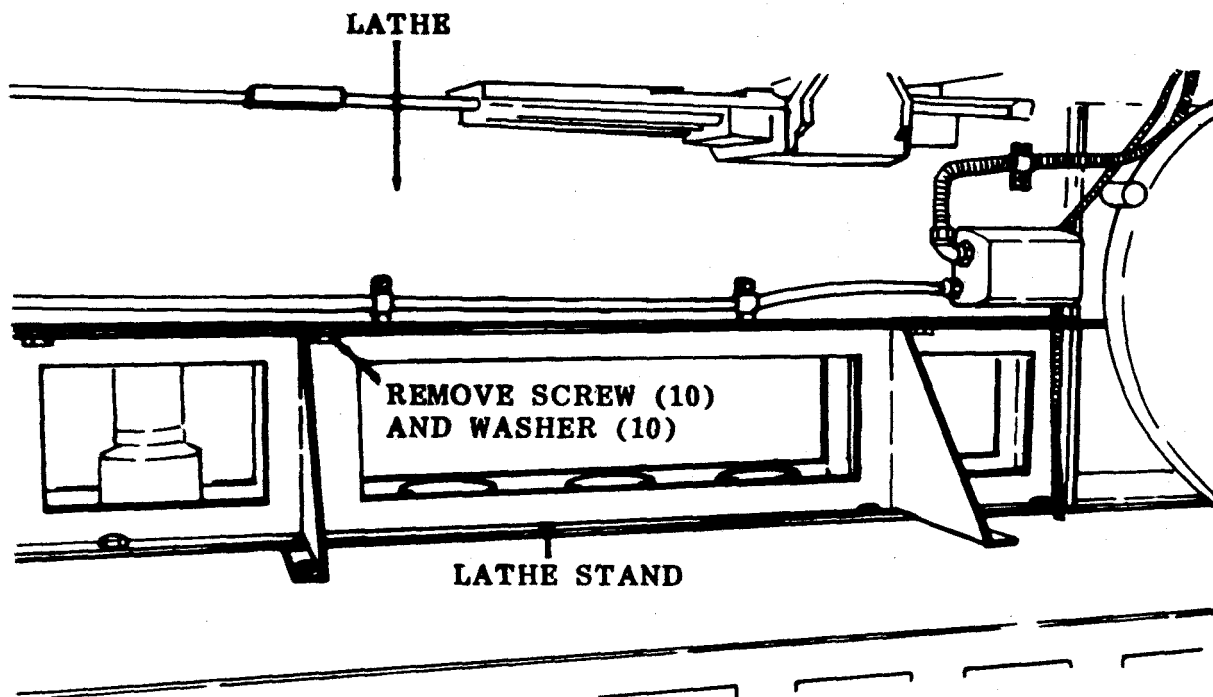
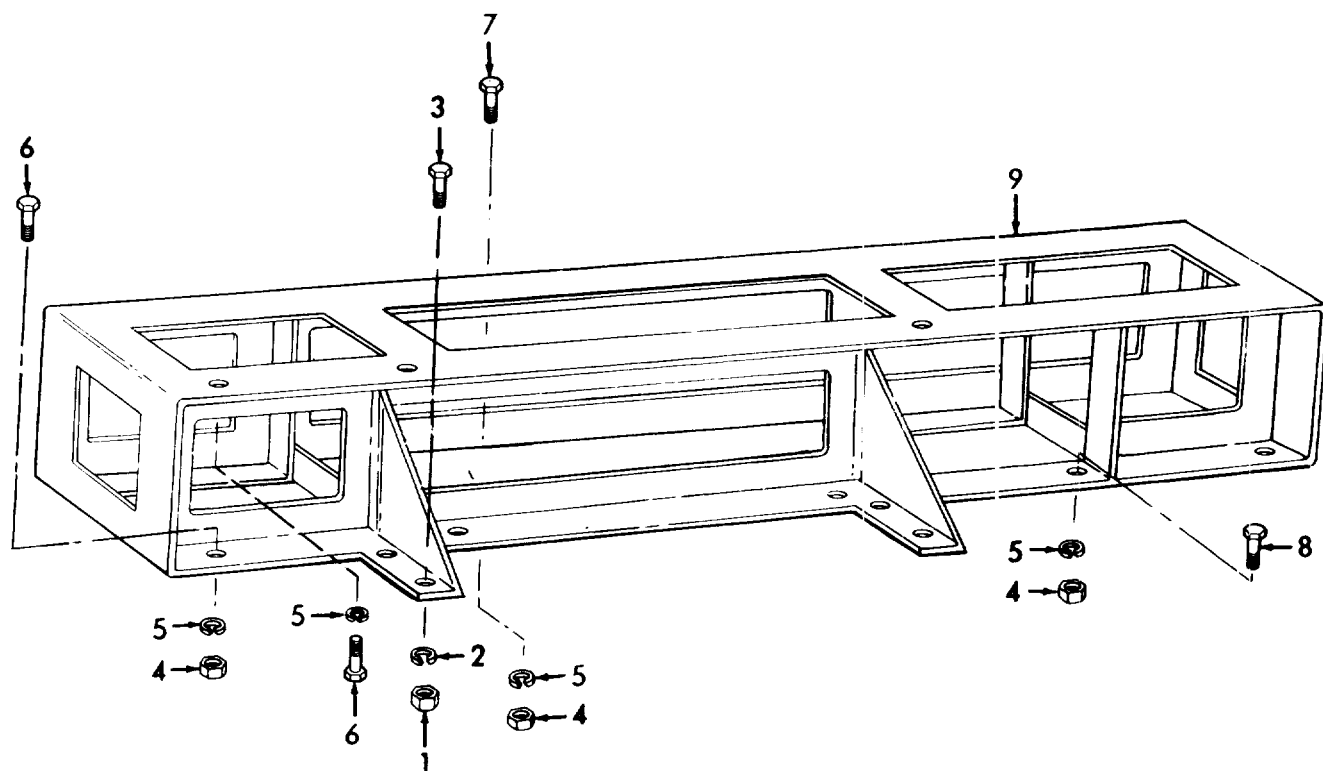


Figure 15-11. Lathe, Removal and Installation.



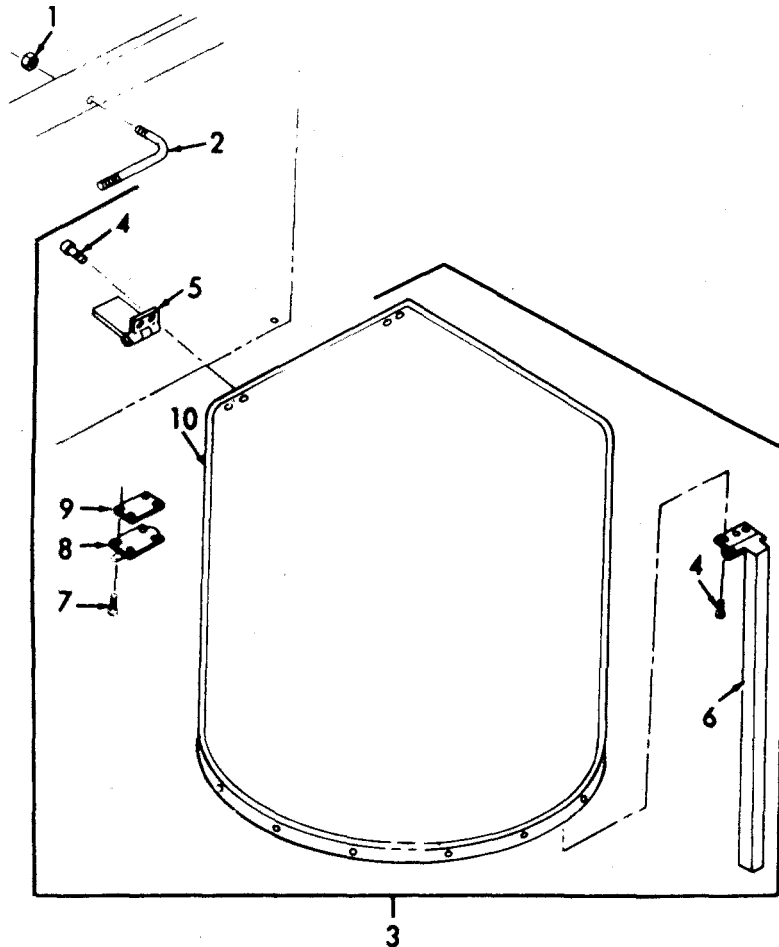
LEGEND FOR FIGURE 15-12:

I	NSN	P/N	FSCM	QTY
1. Nut, Plain	5310-00-768-0318	MS51967-14	96906	4
2. Washer, Lock	5310-00-584-5272	MS35338-48	96906	4
3. Capscrew	5305-00-071-1767	MS90725-110	96906	4
4. Nut, Plain	5310-00-763-8921	MS51967-23	96906	10
5. Washer, Lock	5310-00-584-7888	MS35338-51	96906	20
6. Capscrew	5305-00-880-4012	MS90725-185	96906	13
7. Capscrew	5305-00-082-6766	MS90725-191	96906	4
8. Capscrew	5305-00-050-4212	MS90725-186	96906	3
9. Stand, Lathe		13217E0546	97403	1

Figure 15-12. Lathe Stand, Removal and Installation.

**15-14. HINGED TABLE.**

- a. Removal. Remove the hinged table as illustrated by figure 15-13.
- b. Installation. Install the hinged table as illustrated by figure 15-13.



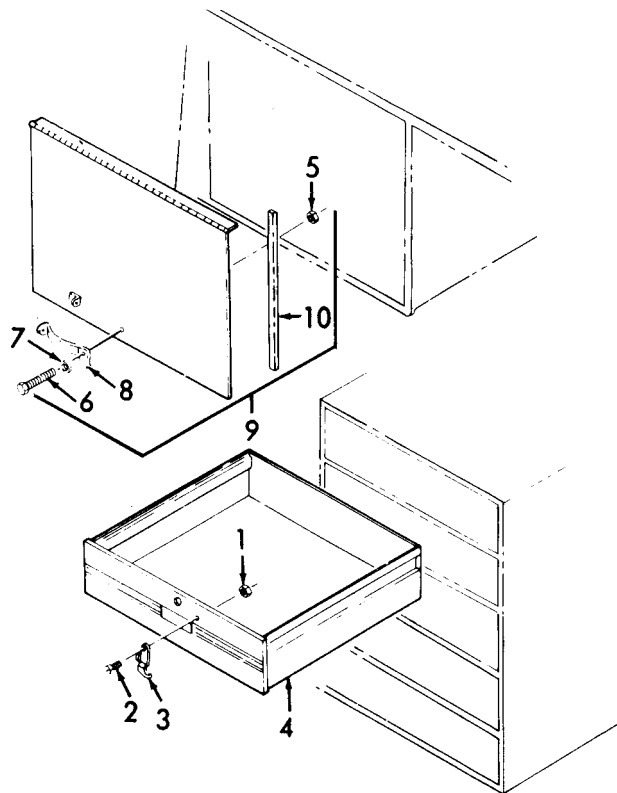
**LEGEND FOR FIGURE 15-13:**

ITEM	NSN	P/N	FSCM	QTY
1. Nut, Self-Locking	5310-00-225-6993	MS51922-33	96906	2
2. Latch		13217E1130	59678	1
3. Table		13217E1128	59678	1
4. Screw, Wood		MS35492-52	96906	8
5. Hinge		MS27973-1	96906	2
6. Leg, Table	4940-00-349-8896	13217E1120	59678	1
7. Screw, Machine		MS35494-28	96906	4
8. Spacer, Bolt		13217E1126	59678	1
9. Bolt, Barrel	5340-00-498-6120	13217E1129	97403	1
10. Top, Table		13217E1127	59678	1

Figure 15-13. Hinged Table, Removal and Installation.

**15-15. CABINET ASSEMBLY.**

- a. Removal. Remove the cabinet doors and handles as illustrated in figure 15-14.
- b. Installation. Install the cabinet doors and handles as illustrated in figure 15-14.



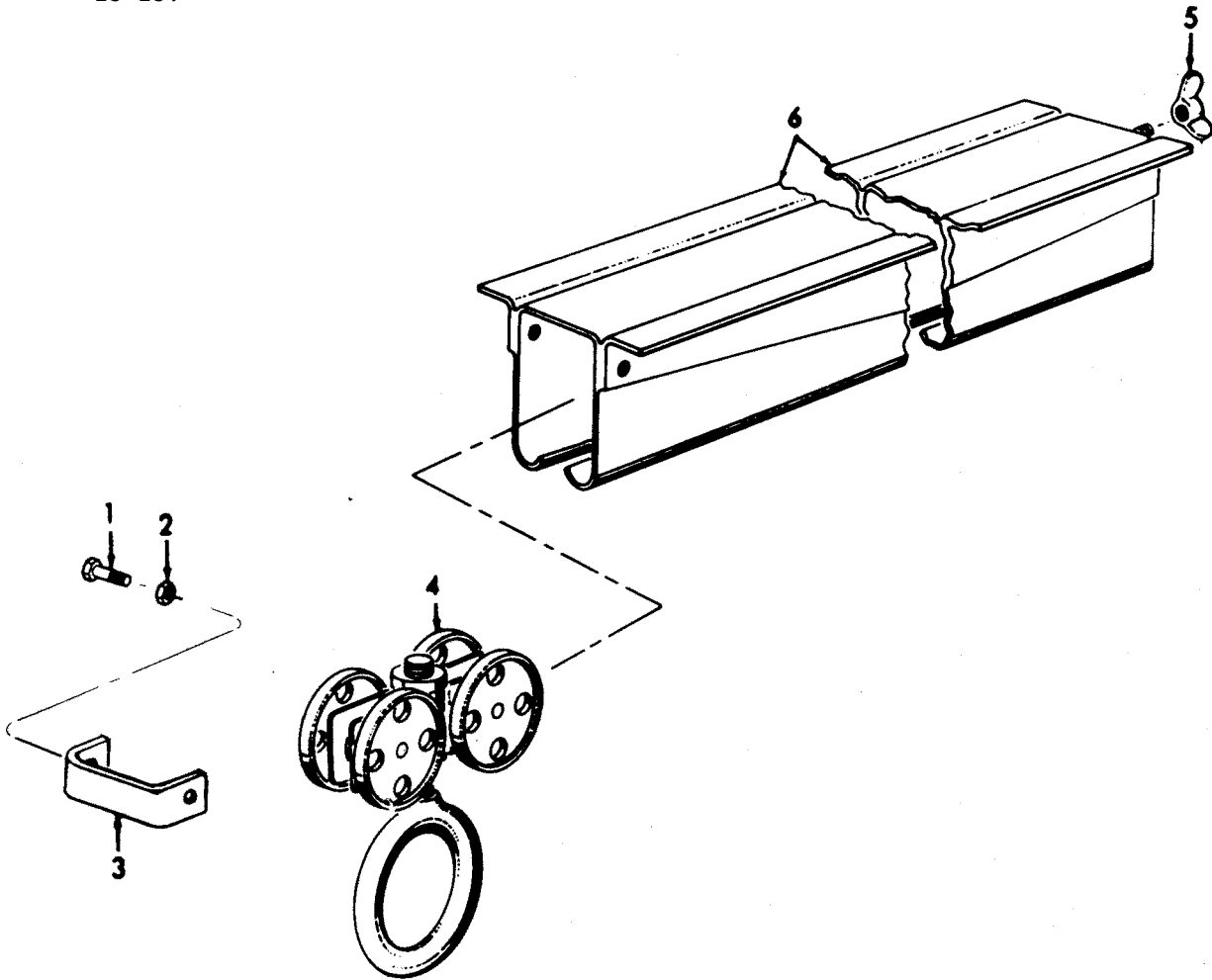
LEGEND FOR FIGURE 15-14:

ITEM	NSN	P/N	FSCM	QTY
1. Nut, Self-Locking	5310-00-208-1918	AN365-L024A	88044	10
2. Screw, Machine	5305-00-984-6210	MS35206-263	96906	10
3. Hook, Drawer		03719A	13689	10
4. Drawer		13217E1112	59678	5
5. Nut, Self-Locking	5310-00-088-1251	MS51922-1	96906	4
6. Screw, Cap	5305-00-068-0502	MS90725-6	96906	4
7. Washer, Flat	5310-00-809-4058	MS27183-10	96906	4
8. Handle		13217E1155	59678	4
9. Door, Cabinet		13217E1091	59678	2
10. Gasket, Door	5330-00-201-5650	13217E1019	97403	2

Figure 15-14. Cabinet Assembly, Removal and Installation.

**15-16. TRACK AND TROLLEY ASSEMBLY.**

- a. Removal. Remove the trolley assembly as illustrated by figure 15-15.
- b. Installation. Install the trolley assembly as illustrated by figure 15-15.



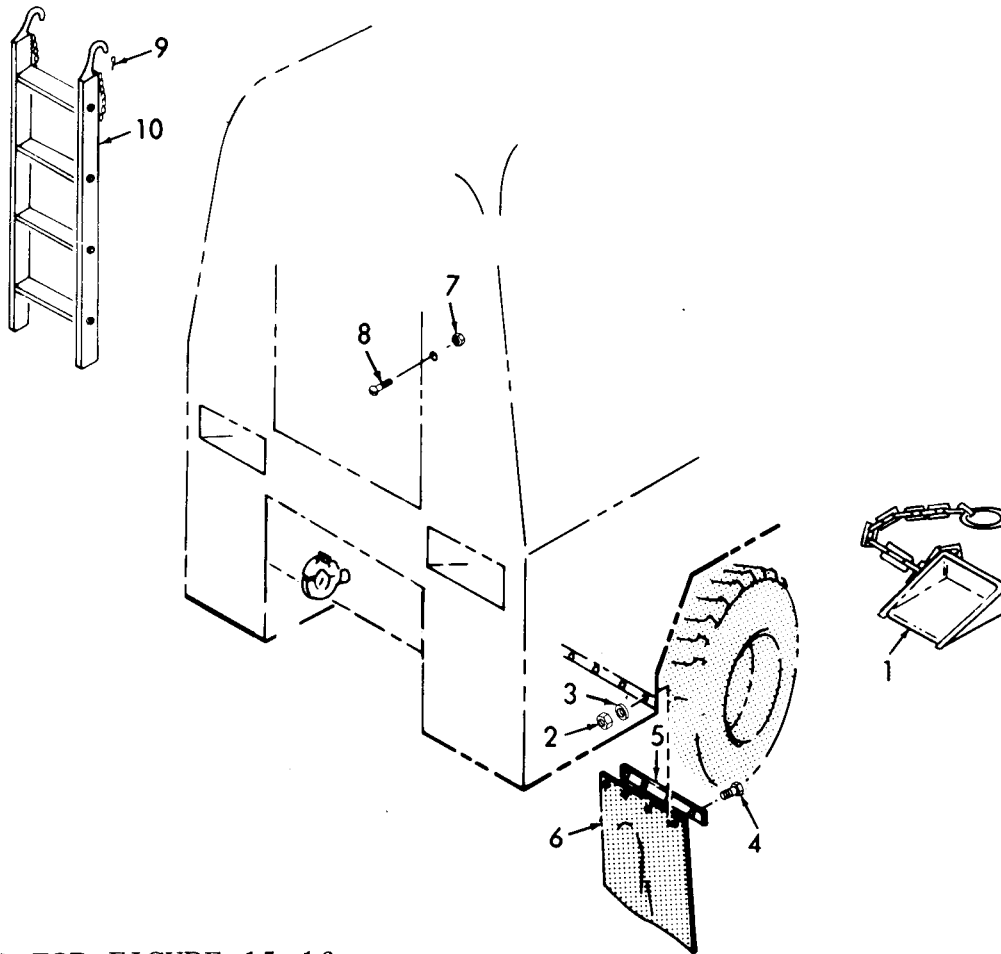
**LEGEND FOR FIGURE 15-15:**

ITEM	NSN	P/N	FSCM	QTY
1. Screw, Cap	5305-00-269-3213	MS90725-62	96906	6
2. Nut, Plain	5310-00-732-0558	MS51967-8	96906	6
3. Stop, Top Hoist	4940-00-349-8898	13217E1134	59678	1
4. Carrier, Eyebolt		13217E1226	59678	1
5. Nut, Wing	5310-00-543-4717	MS35425-28	96906	1
6. Track Assy		13217E1133	59678	1

Figure 15-15. Track and Trolley Assembly, Removal and Installation.

**15-17. MISCELLANEOUS VAN BODY COMPONENTS.**

- a. Remove. Remove any of the miscellaneous van body components as illustrated by figure 15-16.
- b. Installation. Install any of the miscellaneous van body components as illustrated by figure 15-16.



LEGEND FOR FIGURE 15-16:

I TEM	NSN	P/N	FSCM	QTY
1. Chock Assy , Wheel	2540-01-124-5227	10869550	19207	2
2. Nut , Plain	5310-00-761-6882	MS51967-2	96906	8
3. Washer , Lock	5310-00-582-5965	MS35338-44	96906	12
4. Screw, Cap	5305-00-068-0502	MS90725-6	96906	295
5. Retainer, Mud Flap		13217E1140	59678	2
6. Flap , Mud		13217E1141	59678	2
7. Nut , Self-Locking	5310-00-177-1309	MS51988-1	96906	3
8. Screw, Machine	5305-00-984-6210	MS35206-263	96906	28
9. Pin, Cotter	5315-00-187-9567	MS24665-500	96906	4
10. Ladder	2540-00-285-1365	13217E1012	59678	2

Figure 15-16. Miscellaneous Van Body Components, Removal and Installation.



## CHAPTER 16

### MAINTENANCE OF PERSONNEL HEATER

#### 16-1. PERSONNEL HEATER.

- a. Removal (Refer to figure 16-1). Disconnect overflow line, thermostat lead, fuel line, and power. Remove heater as illustrated in figure 16-1.
- b. Repair. Refer to TM 5-4520-227-14.
- c. Installation. Install the heater as illustrated in figure 16-1.

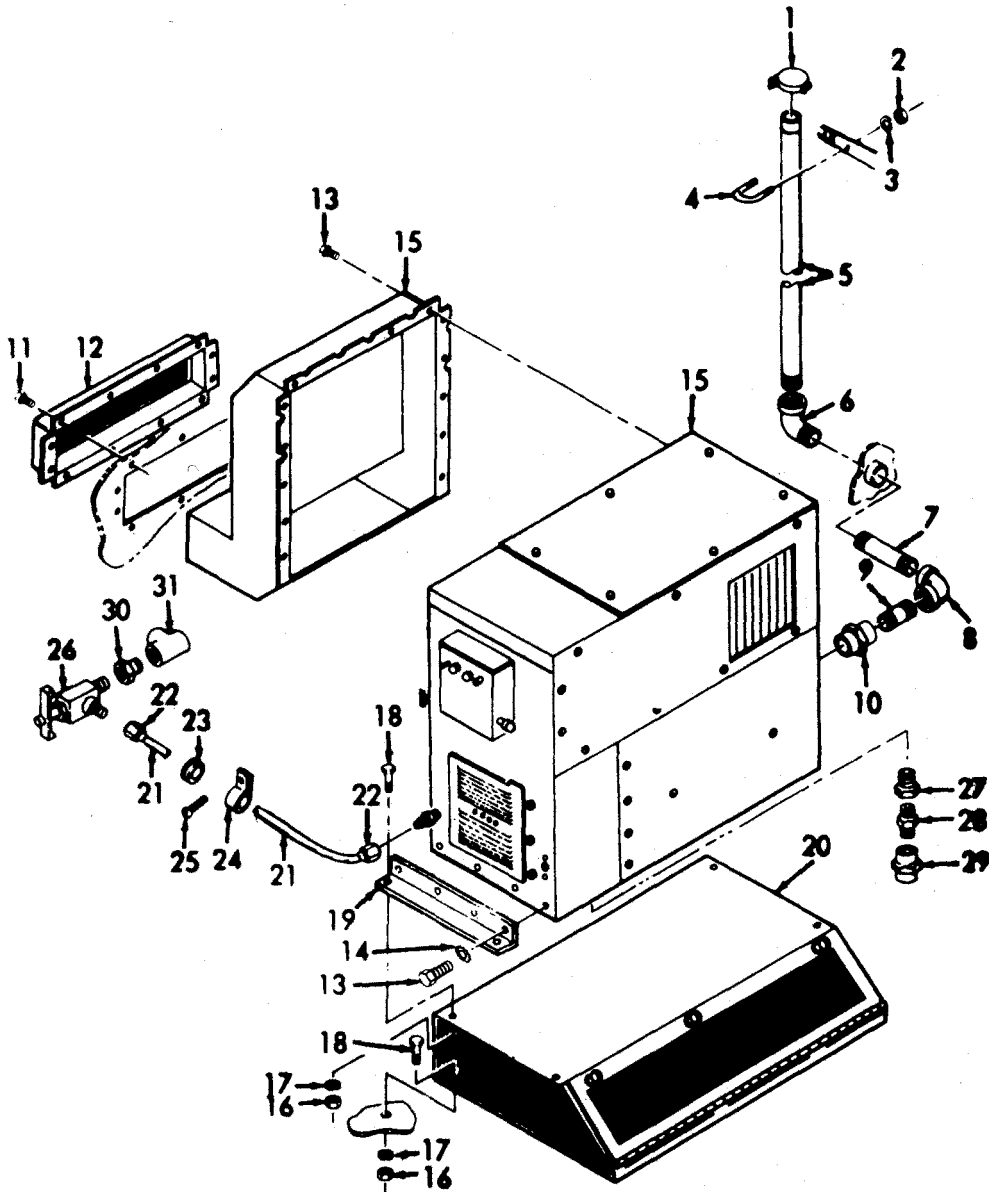
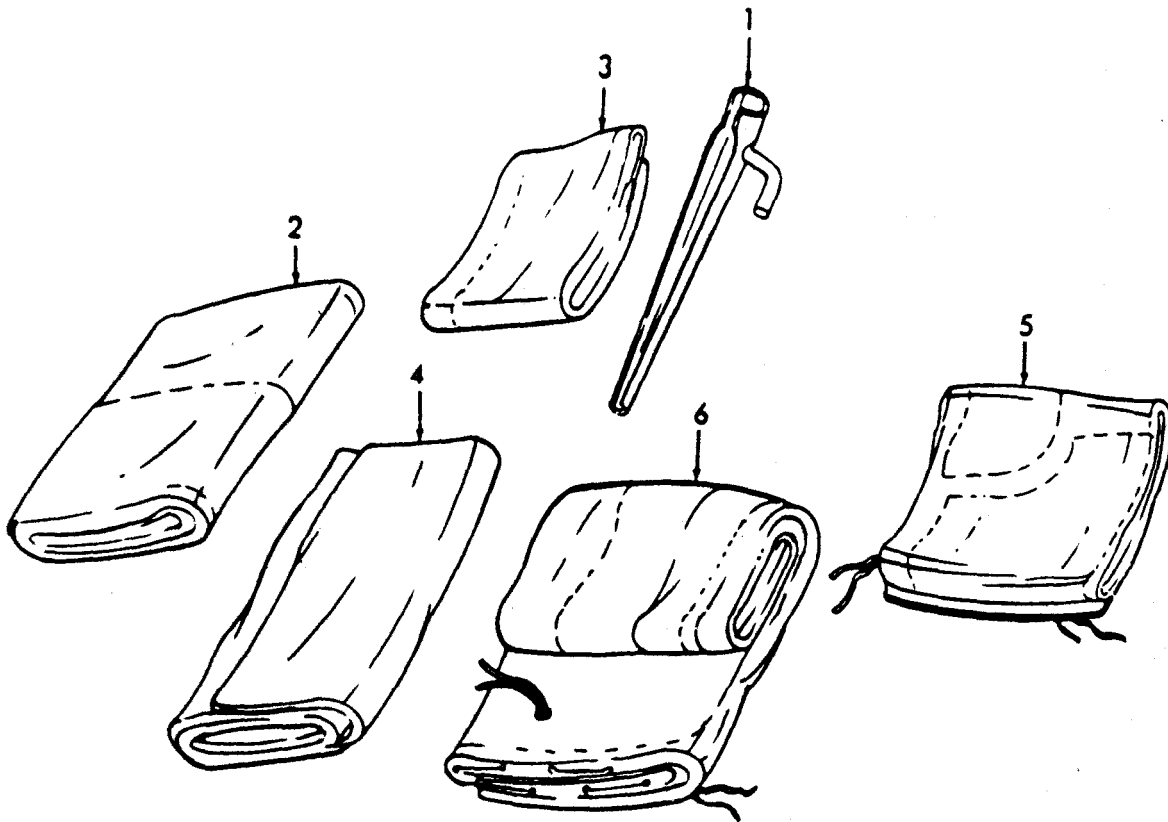


Figure 16-1. Personnel Heater, Removal and Installation.

## LEGEND FOR FIGURE 16-1:

ITEM	NSN	P/N	FSCM	QTY
1. Cap, Rain	2990-00-457-0107	11006	81859	1
2. Nut, Plain	5310-00-761-6882	MS51967-2	96906	2
3. Washer, Lock	5310-00-582-5965	MS35338-44	96906	2
4. Bolt, U		13217E0536	59678	1
5. Pipe, Exhaust		13217E0538	59678	1
6. Elbow, Pipe	4730-00-253-4419	MS39230-9	96906	1
7. Pipe, Exhaust		13217E1187-2	59678	1
8. Elbow		13218E0058-29	97403	1
9. Nipple	4730-00-196-1535	MS51953-195	96906	1
10. Union		13218E0476-48	97403	1
11. Screw	5305-00-432-4201	MS51861-45	96906	12
12. Guard		13217E0463	59678	1
13. Screw	5305-00-879-7941	MS24617-31	96906	18
14. Washer, Flat	5310-00-081-4219	MS27103-12	96906	8
15. Heater	4520-00-683-8595	MILH11511	81349	1
16. Nut, Plain	5310-00-880-7744	MS51967-5	96906	10
17. Washer, Lock	5310-00-407-9566	MS35338-45	96906	1
18. Bolt, Machine	5306-00-225-8497	MS90725-32	96906	10
19. Bracket		13217E0466	59678	1
20. Deflector		13217E0529	59678	1
21. Tube, Copper	4710-00-277-5525	8689206	19207	1
22. Nut	4730-00-011-6452	MS39166-3	96906	3
23. Grommet	5325-00-202-4004	MS35490-52	96906	2
24. Clamp	5340-00-079-7837	MS21333-67	96906	2
25. Screw	5305-00-855-0957	MS24629-46	96906	4
26. Valve		13217E1065-2	59678	2
27. Coupling, Pipe	4730-00-223-9258	13218E0290-2	97403	1
28. Nipple	4730-00-186-7798	AN911-2	88044	1
29. Coupling	4730-00-223-9258	AN910-1	88044	1
30. Bushing	4730-00-011-9922	AN912-1	88044	1
31. Tee	4730-00-278-3990	AN917-2	88044	1



LEGEND FOR FIGURE 16-2:

ITEM	NSN	P/N	FSCM	QTY
1. Pin		MILP501TY1	81349	36
2. Cover, Section, Vehicle	4940-01-054-1568	13217E0954	59678	1
3. Cover, Section, Vehicle	4940-01-067-2140	13217E0951	59678	1
4. Cover, Section, Vehicle	4940-01-054-1567	13217E0950	59678	2
5. Curtain, Forward Center		11021085	59678	1
6. Tent Section, RH		13217E0952	59678	1

Figure 6-2. Tent Curtains.



## CHAPTER 17

### MAINTENANCE OF SIDE LIFTING HYDRAULIC SYSTEM

---

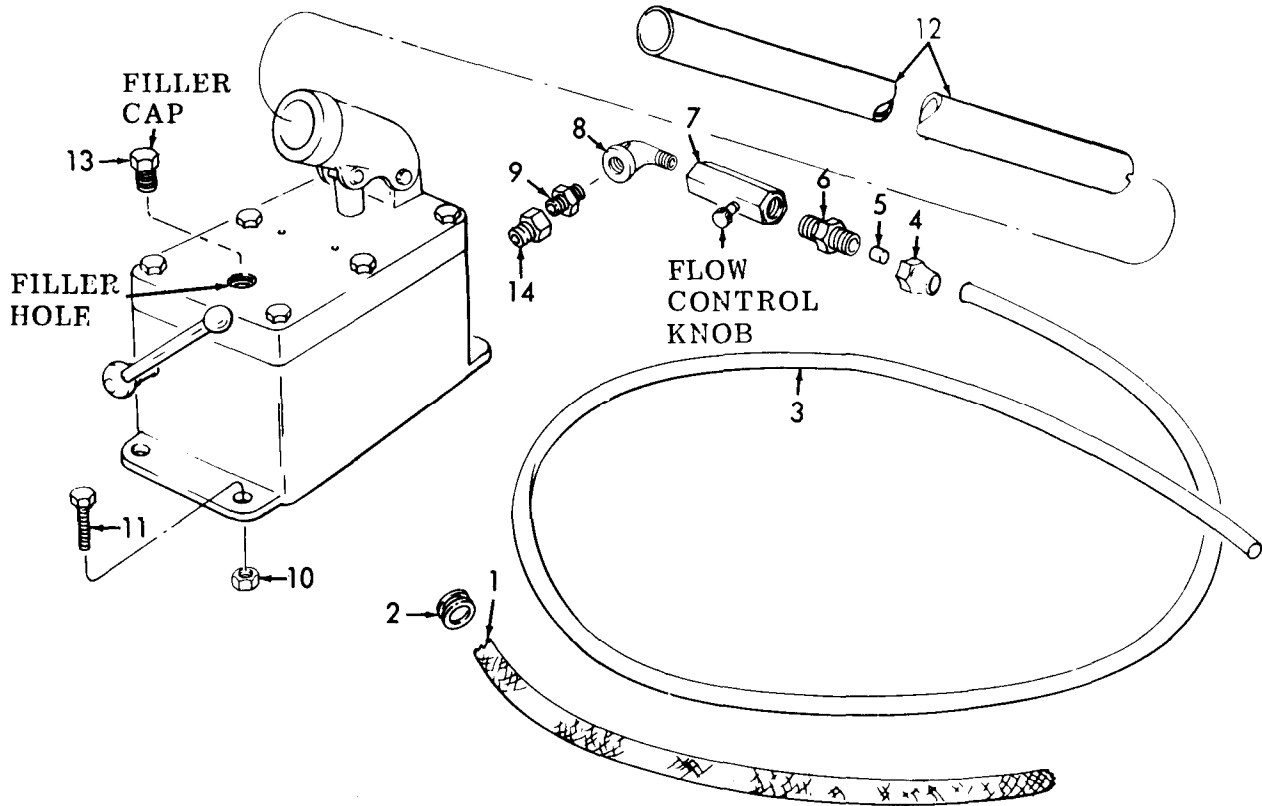
**17-1. GENERAL.** Each side of the mobile shop set is raised and lowered by an independent hydraulic pump and cylinder. Each hydraulic pump supplies oil under pressure to the side lifting cylinder. The cylinder is lowered by releasing the control valve lever on the hydraulic pump. A flow control valve in the system provides a metered flow rate and controls the lowering speed of the cylinder when the control valve lever is placed in the open or return position.

**17-2. FLOW CONTROL VALVE.**

- a. Adjustment. Adjust the flow control valve as illustrated in figure
- b. Removal. Remove flow control valve.
- c. Cleaning and Inspection.
  - (1) Clean all parts in cleaning solvent and dry thoroughly.
  - (2) Inspect for damage or defects and replace a defective flow control valve.
- d. Installation. Install the flow control valve.

**17-3. SIDE LIFTING HYDRAULIC PUMPS.**

- a. General. The side lifting hydraulic pumps are mounted on the front of the shop set body; one on each side. Each pump is manually operated by a handle stored on the front of the body adjacent to each pump. The pumps are secured to permanent mounting brackets welded to the shop set body.
- b. Removal.
  - (1) Disconnect the hydraulic line (fig. 17-1 ) from the flow control valve.
  - (2) Remove four screws, nuts, and washers; and remove the hydraulic pump from the bracket.
  - (3) Remove the flow control valve from the elbow and remove the elbow from the hydraulic pump.
- c. Cleaning and Inspection.
  - (1) Clean external surface of the pump with a cloth dampened in cleaning solvent and wipe dry.



ADJUSTMENT PROCEDURE :

1. TO DECREASE RETURN FOR OF HYDRAULIC OIL FROM THE CYLINDER, TURN THE FLOW CONTROL KNOB CLOCKWISE.
2. TO INCREASE RETURN FLOW OF HYDRAULIC OIL FROM THE CYLINDER, TURN THE FLOW CONTROL KNOB COUNTERCLOCKWISE .

LEGEND FOR FIGURE 17-1:

ITEM	NSN	P/N	FSCM	QTY
1. Tube, Flexible	5975-00-284-7338	8376127	19207	1
2. Grommet, Rubber	5325-00-174-9332	MS35490-48	96906	4
3. Tube	4710-00-102-0108	MILT3520TYPE2	81349	2
4. Nut, Tube	4730-01-024-7933	MS51536B6	96906	2
5. Sleeve, Tube	4730-01-025-4161	MS51533B6	96906	4
6. Adapter	4730-00-194-1121	AN816-6	88044	2
7. Valve, Flow Cont.	4820-00-451-3564	13217E1075	59678	2
8. Elbow, Pipe	4730-00-231-5602	AN914-2	88044	2
9. Nipple, Pipe	4730-00-186-7798	AN911-2	88044	2
10. Nut, Self-Locking	5310-00-984-3806	MS51922-9	96906	8
11. Bolt, Machine	5306-00-226-4830	MS90725-37	96906	8
12. Handle, Pump	4210-00-793-7751	P147-70	07505	1
13. Plug, Pipe	4730-00-289-5176	MS49005-8	96906	1
14. Bushing, Pipe	4730-00-278-3912	FZ1630	07505	1

Figure 17-1. Hydraulic Pump, Removal and Installation.

- (2) Inspect for cracks, breaks, signs of leakage and other damage.
  - (3) Replace a defective side lifting hydraulic pump.
- d. Installation.
- (1) Install the flow control valve in the elbow and install the elbow in the hydraulic pump (fig. 17-1).
  - (2) Install the hydraulic pump in the bracket and secure with screws, nuts, and washers. Connect line to flow control valve.
- e. Bleeding Side Lifting Hydraulic System.

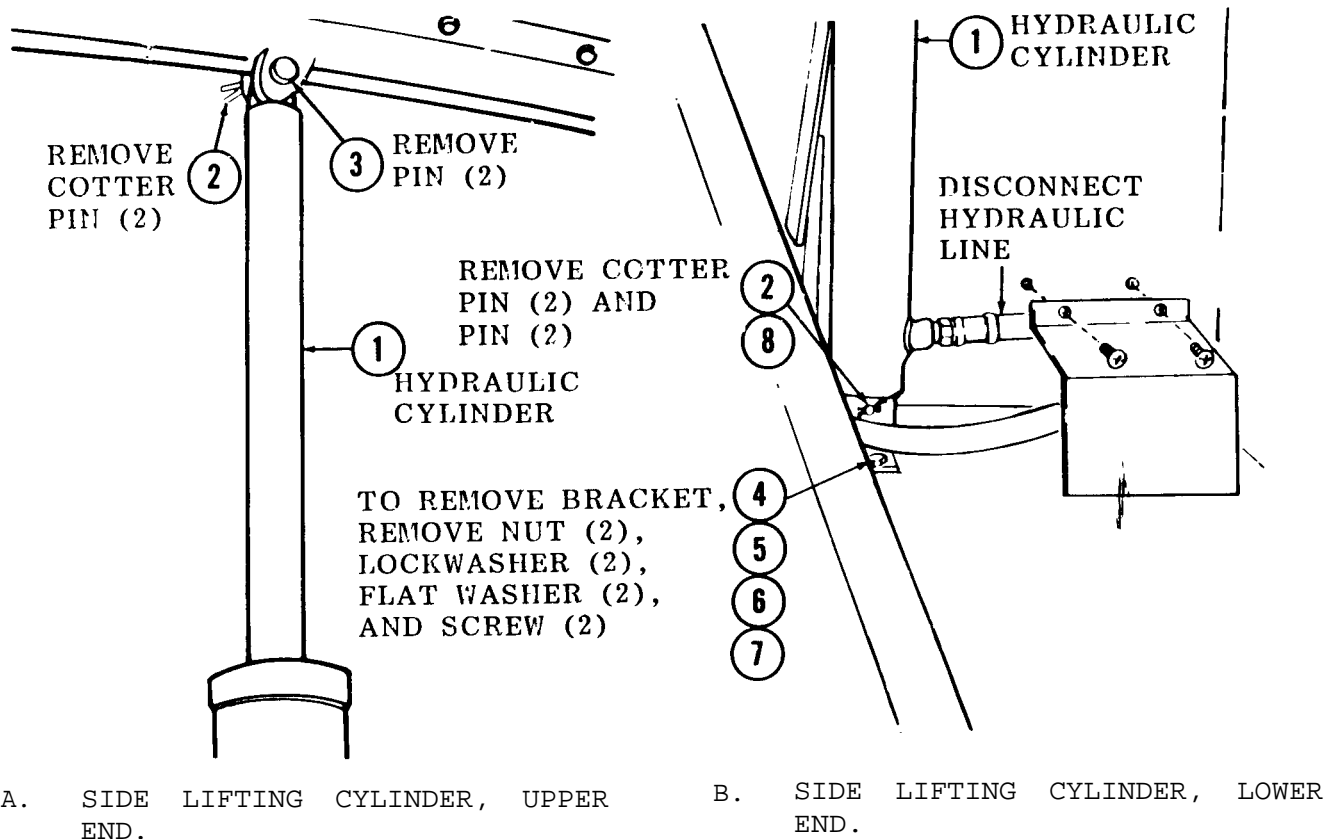
#### NOTE

See that all leaks are corrected before bleeding the side lifting hydraulic system.

- (1) Remove the filler cap (fig. 17-1) from the top of the pump and add fluid as necessary. Install and tighten filler cap.
- (2) Pressurize the system and raise the side. When the cylinder assembly reaches one-third its extended position, any air in the system can be bled by loosening the hydraulic line connection, at the flow control valve, just enough that air in the line can escape. When hydraulic fluid begins to appear, tighten the connection. Refill the hydraulic pump after bleeding and while side door is closed.

#### 17-4 SIDE LIFTING CYLINDERS AND HYDRAULIC LINES.

- a. General. A side lifting cylinder is located on each side of the shop set body. The upper end of each cylinder is attached to a rib in its respective side door. The lower end of each is connected to a removable bracket secured to the shop set floor. Hydraulic oil flows into and out of the cylinders through a flexible line connected at the bottom of each cylinder.
- b. Removal.
- (1) Raise the side door on which the side lifting cylinder is to be removed and secure in the raised position.
  - (2) Remove the side lifting cylinder and hydraulic lines as illustrated in figure 17-2.
- c. Cleaning, Inspection, and Repair.
- (1) Clean all parts with cleaning solvent and dry thoroughly.
  - (2) Inspect all parts for cracks, breaks, wear, and other defects.



CAUTION: MAKE SURE THAT SIDE STRUTS ARE SECURELY LOCKED IN POSITION BEFORE REMOVING SIDE LIFTING CYLINDER.

LEGEND FOR FIGURE 17-2:

ITEM	NSN	P/N	FSCM	QTY
1. Cylinder, Assembly	3040-00-922-0243	13217 E1092	59678	2
2. Pin, Cotter	5315-00-059-0157	MS24665-210	96906	4
3. Pin, Straight, Headed	5315-00-957-2399	MS20392-5C35	96906	2
4. Nut, Plain	5310-00-761-6882	MS51967-2	96906	4
5. Washer, Lock	5310-00-582-5965	MS35338-44	96906	4
6. Washer, Flat	5310-00-809-3078	MS27183-11	96906	4
7. Screw, Cap	5805-00-071-2239	MS90725-12	96906	4

Figure 17-2. Side Lifting Cylinder and Hydraulic Hose, Removal and Installation.



(3) Replace a defective side lifting cylinder or related parts and lines that cannot be repaired.

d. Installation.

- (1) Install the side lifting cylinder and lines as illustrated in figure 17-2.
- (2) Lower the side door.
- (3) Bleed the side lifting cylinder and lifting door hydraulic system.

#### 17-5. SIDE LIFTING CYLINDERS AND HYDRAULIC LINES.

a. General. A side lifting cylinder is located on each side of the shop set body. The upper end of each cylinder is attached to a rib in its respective side door. The lower end of each is connected to a removable bracket secured to the shop set floor. Hydraulic oil flows into and out of the cylinders through a flexible line connected at the bottom of each cylinder.

b. Removal. Remove the side lifting cylinder,

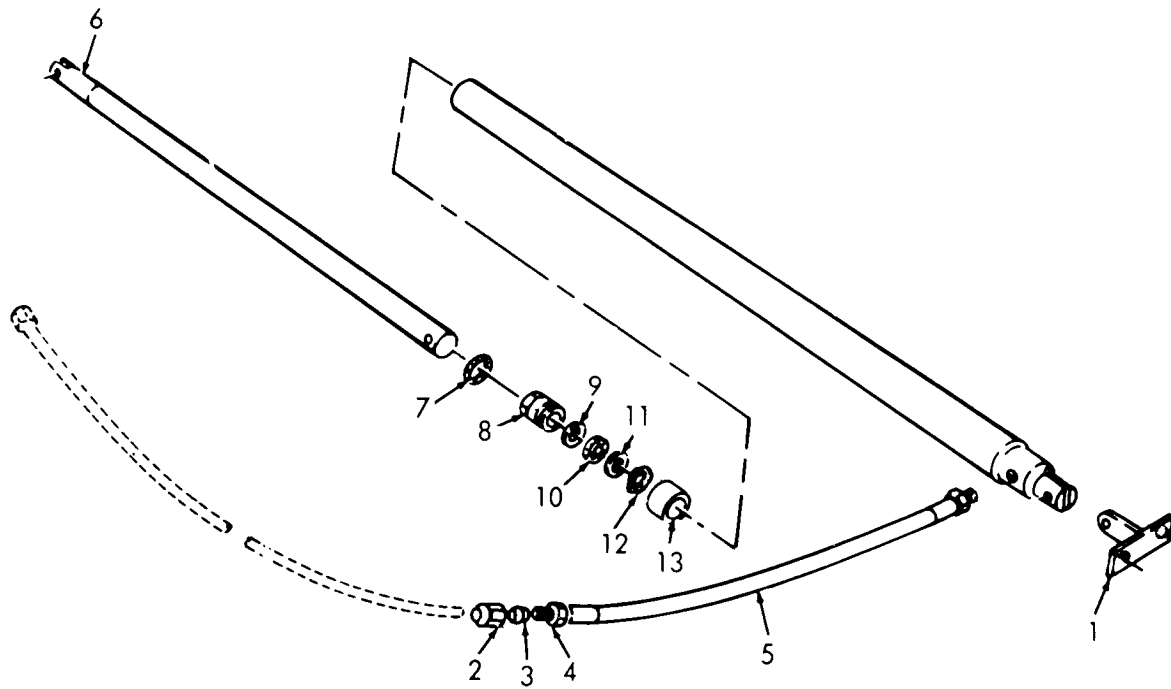
c. Disassembly. Refer to figure 17-3 and disassemble the side lifting cylinder.

d. Cleaning, Inspection, and Repair.

- (1) Clean all parts with an approved cleaning solvent and dry thoroughly.
- (2) Inspect all parts for cracks, breaks, wear and other defects. Inspect the interior surface of the cylinder for pits, roughness, and scored condition.
- (3) Install new packing kit, which includes the wiper O-rings and backup washers.
- (4) Replace a damaged or defective side lifting cylinder or related parts.

e. Reassembly and Installation.

- (1) Reassemble in reverse order of disassembly.
- (2) Install the side lifting cylinder.



LEGEND FOR FIGURE 17-3:

ITEM	NSN	P/N	FSCM	QTY
1. Nut	5310-00-761-6882	MS51967-2	96906	2
2. Washer	5310-00-582-5969	MS35338-44	96906	2
3. Screw	5305-00-071-2239	MS90725-12	96906	2
4. Bracket		13217E1088	59678	1
5. Nut	4730-01-024-7933	MS51531B6	96906	2
6. Sleeve	4730-01-025-4161	MS51533B6	96906	2
7. Adapter	4730-00-334-7840	13218F0181-7	97403	2
8. Hose Assembly	4720-00-251-0694	13217E1089	97403	1
9. Rod	3040-00-478-0158	1K1502A1	98255	1
10. Wiper		FMAPO23	29260	1
11. Packing Nut	4730-00-433-3737	1K15C2A4	98255	1
12. Washer		PMAPO23	29260	1
13. Gasket	5330-00-225-3039	PMAPO19	29260	1
14. Washer		PMAPO-19	29260	1
15. O-Ring		FMAPHM19	29260	1
16. Piston		1K15023	98255	1
17. Kit, Repair (Contains items 10,12,13,14,15)	5330-00-469-3701	PMCKF895	29260	1

Figure 17-3. Side Lifting Cylinder, Exploded view.

**17-6. SIDE LIFTING HYDRAULIC PUMP.**

- a. Removal. Remove the side lifting hydraulic pump.
- b. Disassembly. Disassemble the side lifting hydraulic pump as illustrated in figure 17-4.
- c. Cleaning, Inspection, and Repair.
  - (1) Clean all metal parts with an approved cleaning solvent and dry thoroughly.
  - (2) Inspect all metal parts for breaks, cracks, nicks, burrs, weak spring tension, damaged threads, and other defects.
  - (3) Remove small nicks and burrs, and replace all damaged parts. Replace all packing and gaskets included in the repair kit.
- d. Reassembly and Installation. Reassemble and install in reverse order of disassembly and removal.

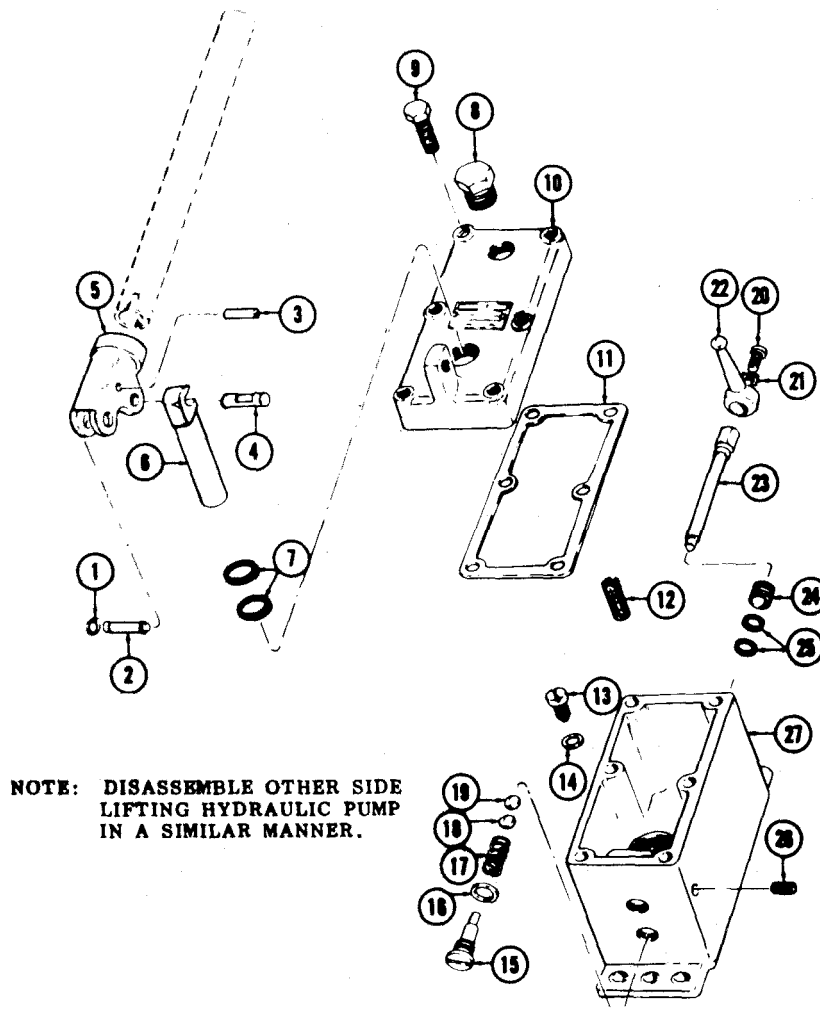


Figure 17-4. Hydraulic Pump, Exploded View.

LEGEND FOR FIGURE 17-4:

ITEM	NSN	P/N	FSCM	QTY
1. Ring, Retaining	5365-00-598-1331	P146-545	07505	2
2. Pin, Straight	5315-00-393-7062	P146-57	07505	1
3. Pin, Spring	5315-00-298-1464	B1096-057	05842	1
4. Pin, Grooved	5315-00-759-7413	P148-57	07505	1
5. Lever	3040-00-808-9337	B8011-060	26953	1
6. Ram, Hydraulic	4320-00-804-5251	H126-900	05842	1
7. Packing	5330-00-529-6257	P12-75	26953	2
8. Plug	4730-00-289-5176	MS49005-8	96906	1
9. Screw		MS90725-38	96906	6
10. Cover	4940-00-474-7380	P146-172	07505	1
11. Gasket	5330-00-377-5503	A1018-037	07505	1
12. Screen	1730-00-303-1089	P307-18	26952	1
13. Setscrew	5120-00-387-9655	CB9-185	07505	1
14. Gasket	5330-00-795-4269	P159-167	07505	1
15. Plug, Valve	1730-00-740-0755	P307-186	07505	1
16. Gasket	5330-00-269-1890	S15-167	05643	1
17. Spring	4910-00-776-5382	H613-183	07505	1
18. Valve	1450-00-996-7221	B1011-016	05842	1
19. Ball	3110-00-812-7349	B1008-016	05842	1
20. Screw	5305-00-984-7363	MS35191-272	96906	1
21. Washer	5310-00-194-9209	MS35336-21	96906	1
22. Lever	3040-00-996-7209	P60-12	96906	1
23. Spindle	1730-00-651-8476	H7-900	07505	1
24. Insert	5340-00-371-6507	P60-11	07505	1
25. Packing	5330-00-477-1453	A1027-074	26953	2
26. Plug	4730-00-018-9566	AX7C74	62983	1
27. Housing	4210-00-797-8334	P307-05	07505	1
28. Kit, Repair, Pump (Contains items 1,2,3,4,5,)	4320-00-137-1751	KH2001	26953	1
29. Kit, Repair, Hydraulic (Contains items 7,11,12,14,18, 19,24,25)	4940-00-186-3199	KH2000	26953	1

## CHAPTER 18

### MAINTENANCE OF CONTROL CUBICLE

#### 18-1. ROTARY SWITCH (10-RANGE).

a. Removal.

(1) Remove four screws and remove welder control panel.

(2) Tag and disconnect electrical leads as necessary.

(3) Remove four screws and lockwashers and remove rotary switch.

b. Disassembly. Refer to figure 18-1, and disassemble rotary switch.

c. Reassembly. Refer to figure 18-1. and reassemble rotary switch.

d. Installation. Install in reverse order of subparagraph 18-1a.

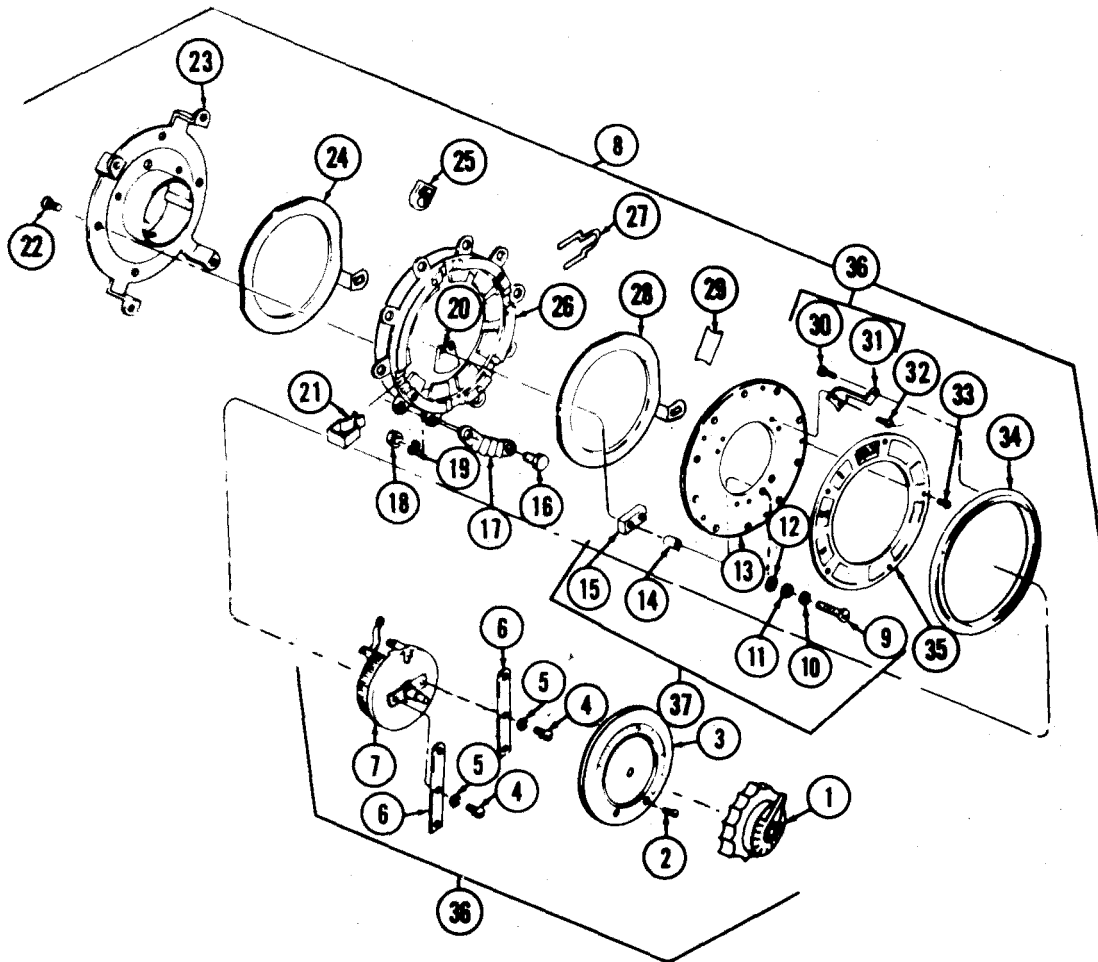


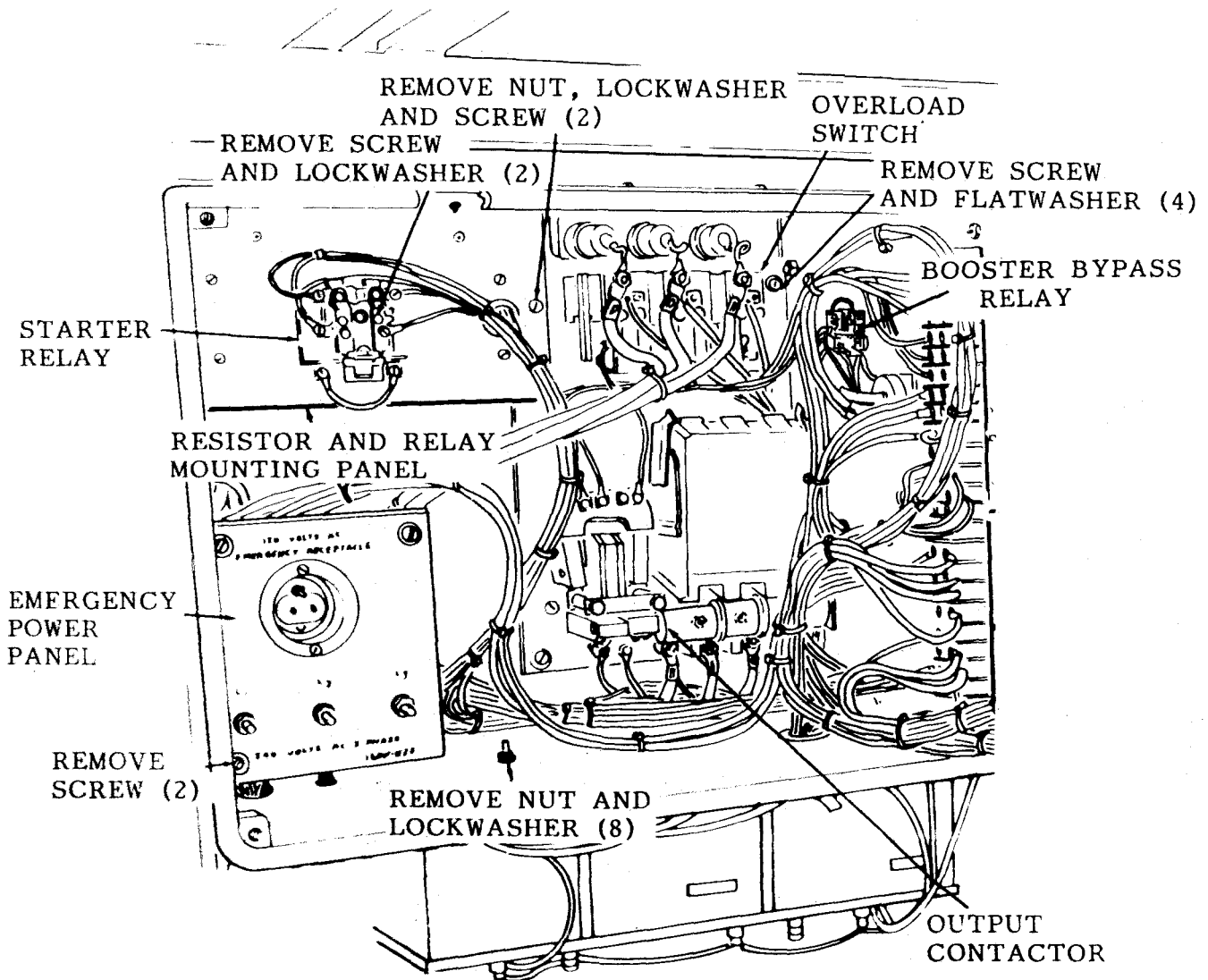
Figure 18-1. Rotary Switch (10-Range), Exploded View.

## LEGEND FOR FIGURE 18-1:

ITEM	NSN	P/N	FSCM	QTY
1. Knob		AAW83 5A	28835	1
2. Screw	5305-01-040-0997	W11224-2	28835	4
3. Dial		401554	28835	1
4. Screw	part of 402153		28835	2
5. Washer	part of 402153		28835	2
6. Bracket		352716	28835	2
7. Resistor Variable	5905-01-054-2007	402153	28835	1
8. Assembly, Switch		358948	28835	1
9. Screw	5305-01-056-1478	W-11114-6	28835	2
10. Washer	5310-00-550-1130	MS35333-40	96906	2
11. Washer	5310-00-480-4143	W11242-5	28835	2
12. Washer	5310-00-447-4192	AK1074	28835	2
13. Disc		AW43 1	28835	1
14. Bushing	5970-00-447-4194	AW-307	28835	2
15. Contact	5999-00-429-0929	AW3 06	28835	1
16. Screw		W11097-17	28835	2
17. Link	5905-00-447-4176	AW335	28835	1
18. Nut	5320-01-055-4441	W11278-5	28835	2
19. Washer	5310-00-680-7297	W11254-6	28835	2
20. Contact	5999-00-374-5039	AW156	28835	2
21. Spring	5999-00-374-5039	W799C70	28835	4
22. Screw	5306-01-038-8685	AW1802	28835	4
23. Housing		361175	28835	1
24. Ring, Contact	5930-00-947-4251	DW89 0A	28835	1
25. Catch	3431-00-447-4197	AW45 9	28835	2
26. Ring, Contact	3431-00-389-9466	DW85 9	28835	1
27. Lead	5940-00-429-0933	AW45 3	28835	4
28. Ring, Contact	5930-00-447-4251	DW890A	28835	1
29. Insulator	5970-00-308-2814	AW-929	28835	2
30. Screw	5305-01-040-0997	W11224-2	28835	3
31. Bracket		AW334	28835	3
32. Screw		8BW823-1	28835	6
33. Screw		AW1675	28835	5
34. Handwheel	5340-00-387-9438	AW212A	28835	1
35. Dial		AW575-2	28835	1
36. Switch Assy		358948	28835	1
37. Dial Assy		AW470-2	28835	±

**18-2 . GENERATOR OUTPUT CONTACTOR.**

- a. Removal. Remove, generator output contactor as illustrated in figure 18-2.
- b. Disassembly. Refer to figure 18-3, and disassemble generator output contactor.
- c. Reassembly. Refer to figure 18-3, and reassemble the generator output contactor.
- d. Installation. Install the generator output contactor in reverse order of removal.



NOTE: TAG AND DISCONNECT ELECTRICAL LEADS AS NECESSARY.

Figure 18-2. Cubicle Control Components, Removal and Installation.

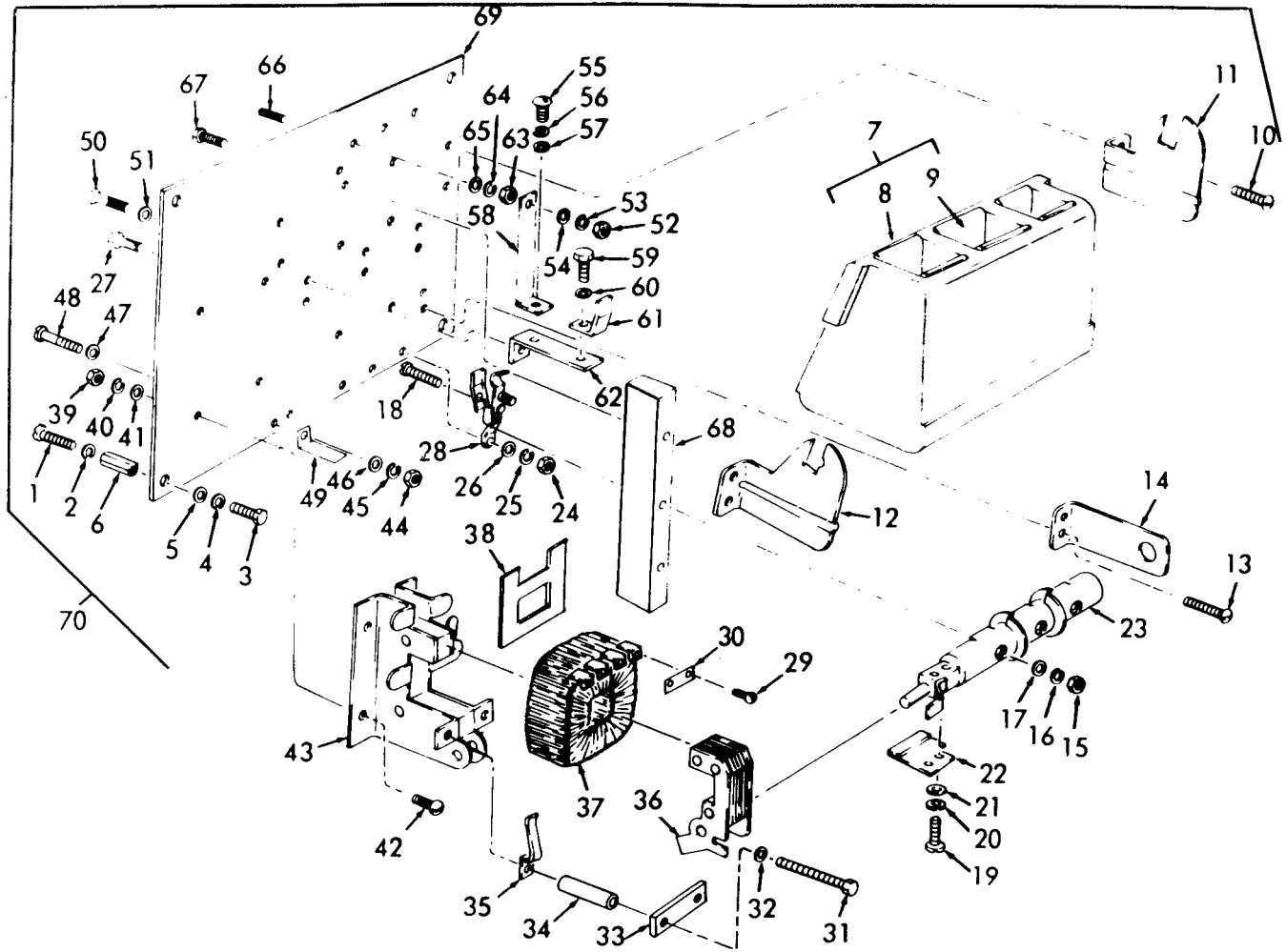


Figure 18-3. Generator Output Contactor, Exploded view.

LEGEND FOR FIGURE 18-3:

ITEM	NSN	P/N	FSCM	QTY
1. Screw	5305-00-988-1727	MS35206-283	96906	4
2. Washer	5310-00-889-2528	MS45904-68	96906	4
3. Screw	5305-00-988-1727	MS35206-283	96906	4
4. Washer	5310-00-889-2528	MS45904-68	96906	4
5. Washer	5310-00-809-3078	MS27183-11	96906	4
6. Spacer		25MS66	28835	4
7. Shield Assy		50MS331A	28835	1
8. Shield, Arc	5925-00-966-2080	50MS727	28835	1
9. Shield, Blowout		50MS704	28835	3
10. Screw	5305-00-057-9612	MS24621-30	96906	4
11. Holder		25MS218	28835	1
12. Holder		25MS219	28835	1
13. Screw	5305-01-057-3040	8BW-824-0	28835	2
14. Support		50MS472	28835	1
15. Nut	5310-00-842-1699	MS35691-4	96906	3
16. Washer	5310-00-582-5965	MS35338-44	96906	3
17. Washer	5310-00-809-3078	MS27183-11	96906	3



18. Screw	5305-00-988-1725	MS35206-281	96906	3
19. Screw	5305-00-984-4988	MS35206-228	96906	2
20. Washer	5310-00-045-4007	MS35338-41	96906	2
21. Washer	5310-00-983-8483	MS27183-5	96906	2
22. Contact	4940-00-735-9061	25MS102	28835	1
23. Shaft		25MS101A	28835	1
24. Nut	5310-00-842-1699	MS35691-4	96906	3
25. Washer	5310-00-045-4007	MS35338-41	96906	3
26. Washer	5310-00-809-3078	MS27183-11	96906	3
27. Screw	5305-00-988-1171	MS35206-285	96906	3
28. Contact		50MS280	28835	3
29. Screw	5305-00-855-0972	MS24669-23	96906	2
30. Link		25MS156	28835	2
31. Screw	5305-00-988-1730	MS35206-289	96906	2
32. Washer	5310-00-582-5965	MS35338-44	96906	2
33. Bar		25MS277A	28835	1
34. Spacer		25MS328	28835	2
35. Bracket	5950-00-404-9673	50MS262	28835	2
36. Yoke		50MS961	28835	1
37. Coil	5950-00-802-8455	1007	28835	1
38. Spacer	4940-00-966-7236	50MS261	28835	1
39. Nut	5310-00-842-1699	MS35691-4	96906	4
40. Washer	5310-00-582-5965	MS35338-44	96906	4
41. Washer	5310-00-809-3078	MS27183-11	96906	4
42. Screw	5305-00-988-1723	MS35206-279	96906	4
43. Yoke	5930-00-831-3979	50MS269	28835	1
44. Nut	5310-00-934-9757	MS35649-282	96906	2
45. Washer	5310-00-045-3299	MS35338-42	96906	2
46. Washer	5310-00-082-1404	MS27183-6	96906	2
47. Washer	5310-00-045-3299	MS35338-42	96906	2
48. Screw	5305-00-984-6195	MS35206-247	96906	2
49. Contact	4940-00-735-9062	25MS198	28835	2
50. Screw	5305-00-068-0499	MS90725-2	96906	3
51. Washer	5310-00-582-5965	MS35338-44	96906	3
52. Nut	5310-00-850-6855	MS35691-12	96906	3
53. Washer	5310-00-407-9566	MS35338-45	96906	3
54. Washer	5310-00-081-4219	MS27183-12	96906	3
55. Screw	5305-00-957-6272	MS35190-269	96906	3
56. Washer	5310-00-045-3296	MS35338-43	96906	3
57. Washer	5310-00-082-1404	MS27183-6	96906	3
58. Mount, Contact	5945-00-469-4392	16DW7 48	28835	3
59. Screw	5305-00-068-0498	MS90725-1	96906	3
60. Washer	5310-00-582-5965	MS35338-44	96906	3
61. Contact	2530-00-966-2079	50MS22A	28835	3
62. Finger, Contact	5945-00-420-1275	16D747	28835	3
63. Nut	5310-00-850-6855	MS35691-12	96906	3
64. Washer	5310-00-407-9566	MS35338-45	96906	3
65. Washer	5310-00-081-4219	MS27183-12	96906	3
66. Screw		W995 2A	28835	3
67. Screw	5305-00-057-9613	MS24621-32	96906	3
68. Baffle		16DW7 45	28835	2
69. Plate		16DW1152	28835	1
70. Contactor Assy		16DW1180	28835	1

18-3. OVERLOAD SWITCH.

- a. Removal. Remove Overload switch as illustrated in figure 18-2.
- b. Disassembly. Refer to figure 18-4, and disassemble the overload switch.
- c. Reassembly. Refer to figure 18-4, and reassemble the overload switch.
- d. Installation. Install overload switch as illustrated in figure 18-2.

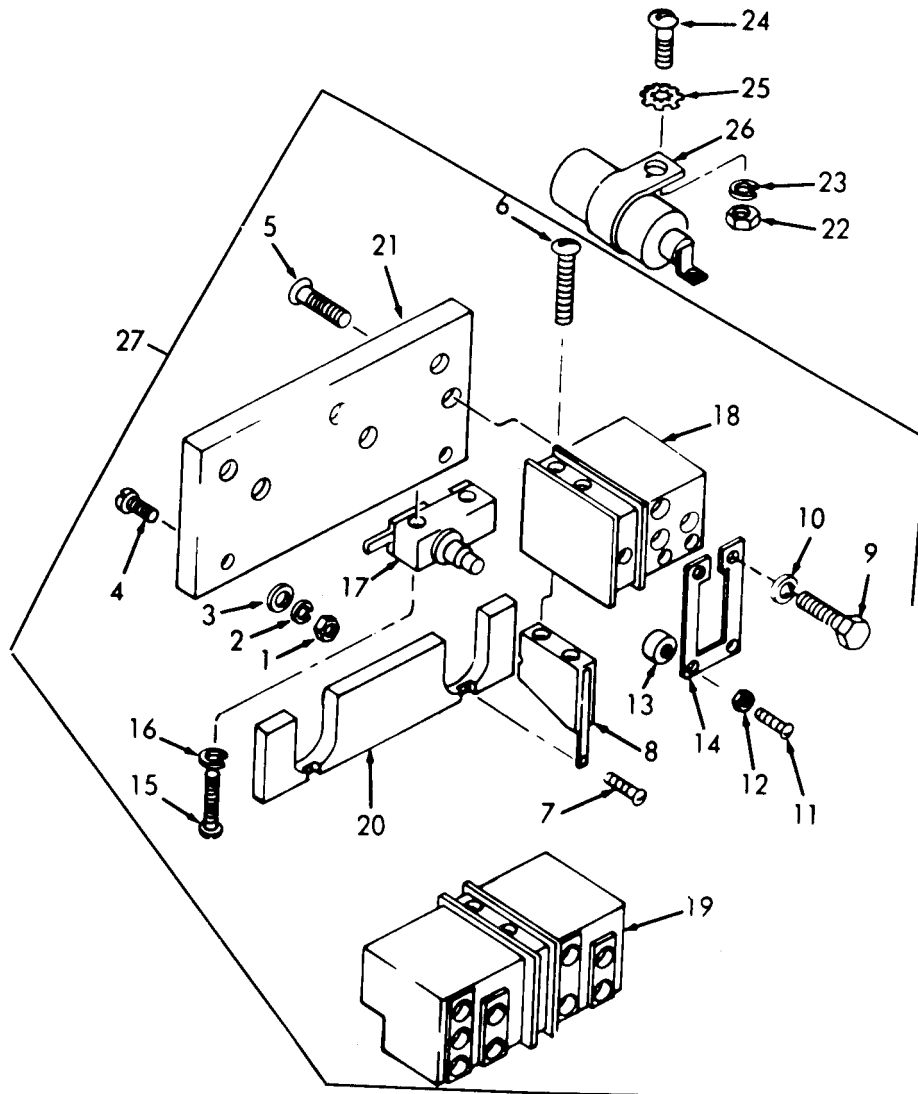


Figure 18-4. Overload Switch, Exploded View.

## LEGEND FOR FIGURE 18-4:

ITEM	NSN	P/N	FSCM	QTY
1. Nut	5310-00-006-8199	W11287-2	28835	4
2. Washer	5310-01-039-0241	W11254-1	28835	4
3. Washer	5310-00-765-2085	W11245-2	28835	4
4. Screw	5305-01-055-4439	W11215-2	28835	4
5. Screw	5305-00-068-0519	W11218-2	28835	3
6. Screw	5305-01-055-4438	W11215-4	28835	2
7. Screw	5305-01-056-3179	W-11223-2	28835	2
8. Contact	5999-01-064-4888	50MS162A	28835	2
9. Screw	5305-00-890-4829	402119-1	28835	3
10. Washer	5310-00-487-1289	W11254-4	28835	3
11. Screw	5305-01-039-2497	W11110-6	28835	1
12. Nut	5310-00-880-7744	MS51967-5	96906	1
13. Nut	5310-00-249-5248	AC632	77122	1
14. Element		50MS879B	28835	1
15. Screw	5905-01-056-1492	W-11221-3	28835	2
16. Washer	5310-00-765-2085	W11245-2	28835	2
17. Switch	5930-00-296-9151	BZ2RD	91929	1
18. Block		50MS819-1	28835	1
19. Block		50MS818-1	28835	2
20. Mount		50MS822	28835	2
21. Base		50MS821A	28835	1
22. Nut	5310-00-850-4770	AW640	28835	3
23. Washer	5310-00-487-1289	W11254-4	28835	3
24. Screw	5305-00-821-7130	W11236-1	28835	3
25. Washer	5310-00-637-9575	4014-20-00	78189	3
26. Capacitor	5910-00-367-7862	CA37AFW254	81349	3
27. Switch Assy	2920-00-966-2081	50MS879	28835	1

## 18-4. RESISTOR AND RELAY MOUNTING PANEL AND EMERGENCY POWER PANEL.

- a. Removal. Remove resistor and relay mounting panel and emergency power panel as illustrated in figure 18-2.
- b. Disassembly. Disassemble the resistor and relay mounting panel and emergency power panel as illustrated in figure 18-5.
- c. Reassembly. Reassemble the resistor and relay mounting panel and emergency power panel as illustrated in figure 18-5.
- d. Installation. Install the resistor and relay mounting panel and emergency power panel in reverse order of removal.

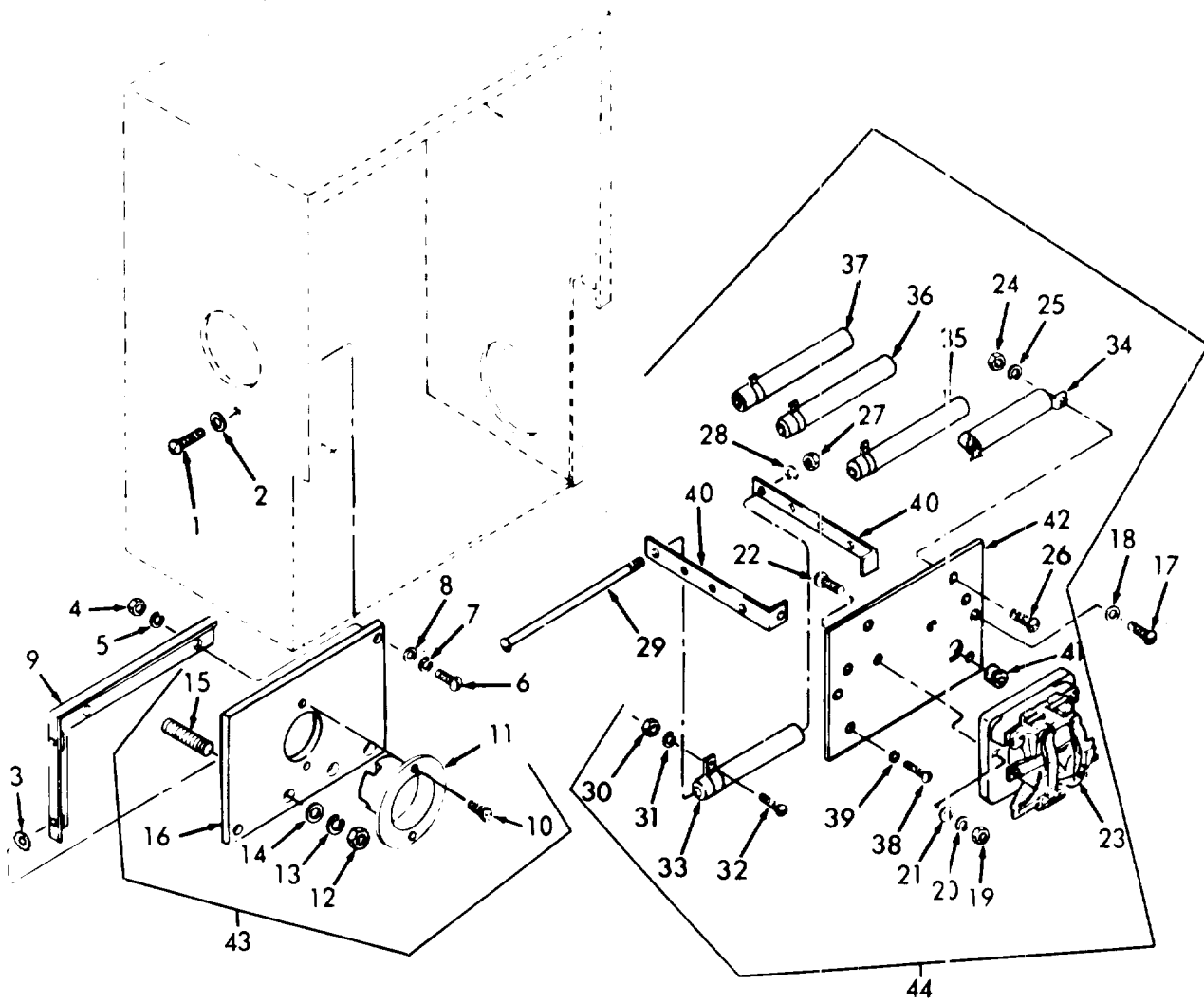


Figure 18-5. Resistor and Relay Mounting Panel, and Emergency Power Panel.

## LEGEND FOR FIGURE 18-5:

ITEM	NSN	P/N	FSCM	QTY
1. Screw	5305-01-039-0229	W11114-2	28835	2
2. Washer	5310-00-487-1289	W11254-4	28835	2
3. Washer	5310-00-889-2528	MS45904-68	96906	2
4. Nut	5310-00-842-1699	MS35691-4	96906	3
5. Washer	5310-00-582-5965	MS35338-44	96906	3
6. Screw	5305-00-869-5013	402119-4	28835	3
7. Washer	5310-00-487-1289	W11254-4	28835	3
8. Washer	5310-00-476-5240	W11242-4	28835	3
9. Bracket		16DW1118	28835	1
10. Screw	5305-01-056-3178	W-11223-3	28835	2
11. Receptacle		5278-2W	74545	1
12. Nut		W11281-3	28835	4
13. Washer	5310-00-707-0690	W11254-5	28835	4
14. Washer		W11242-6	28835	4
15. Stud		29552-1	28835	3
16. Panel		16DW1125	28835	1
17. Screw	5305-01-039-0229	W11114-2	28835	2
18. Washer	5310-00-487-1289	W11254-4	28835	2
19. Nut	5310-00-006-8199	W11287-2	28835	2
20. Washer	5310-01-039-0241	W11254-1	28835	2
21. Washer	5310-00-983-8483	MS27183-5	96906	2
22. Screw	5305-01-039-2497	W11110-6	28835	2
23. Relay	4940-00-735-9057	16DA1625-4	28835	1
24. Nut	5310-00-006-8199	W11287-2	28835	2
25. Washer	5310-01-039-0241	W11254-1	28835	2
26. Screw	5305-00-720-8881	W11110-3	28835	2
27. Nut	5310-00-492-3145	W11280-2	28835	8
28. Washer	5310-01-039-0241	W11254-4	28835	8
29. Screw	5305-00-721-3201	W11114-12	28835	8
30. Nut	5310-00-934-9747	MS35649-262	96906	6
31. Washer	5310-00-045-4007	MS35338-41	96906	6
32. Screw	5305-00-984-4989	MS35206-229	96906	6
33. Resistor	5905-00-539-0643	C957	44655	4
34. Resistor	5905-00-279-5723	CW1150	28835	1
35. Resistor	5905-00-295-5560	W2974M	28835	1
36. Resistor	5905-00-280-1610	W2974N	28835	1
37. Resistor	5905-00-257-9184	W2974O	28835	1
38. Screw	5305-01-047-0969	W11111-9	28835	4
39. Washer	5310-00-707-0694	W11254-2	28835	4
40. Bracket		AAW1199	28835	4
41. Grommet	5325-00-475-9352	W10312-9	28835	1
42. Plate		16DW1119	28835	1
43. Panel Assy		16DW1126	28835	1
44. Plate Armature	4940-01-047-9070	DW1129	28835	1

2

1

**18-5. EXCITER BOOSTER.**

- a. Removal. Remove exciter booster as illustrated in figure 18-2.
- b. Installation. Install the exciter booster as illustrated in figure 18-2.

**18-6. POWER SELECTOR SWITCH.**

- a. On-Equipment Test.
  - (1) Tag and disconnect all leads and jumper wires from the power selector switch.
  - (2) Use a multimeter and test for continuity in (3) thru (5) below. If continuity is not so indicated, replace the power selector switch.
  - (3) Turn the power selector switch to the GENERATOR position. Continuity should be indicated between terminals 1 and 4, 5 and 8, 9 and 12, 13 and 16, 17 and 20, and 21 and 24.
  - (4) Turn the power selector switch to the CITY position. Continuity should be indicated between terminals 1 and 3, 5 and 7, 9 and 11, 13 and 15, 17 and 19, and 21 and 23.
  - (5) Turn the power selector switch to the EMERGENCY position. Continuity should be indicated between terminals 1 and 2, 5 and 6, 9 and 10, 13 and 14, 17 and 18, and 21 and 22.
- b. Removal and Installation. Refer to figure 18-6 for removal and installation of the power selector switch.

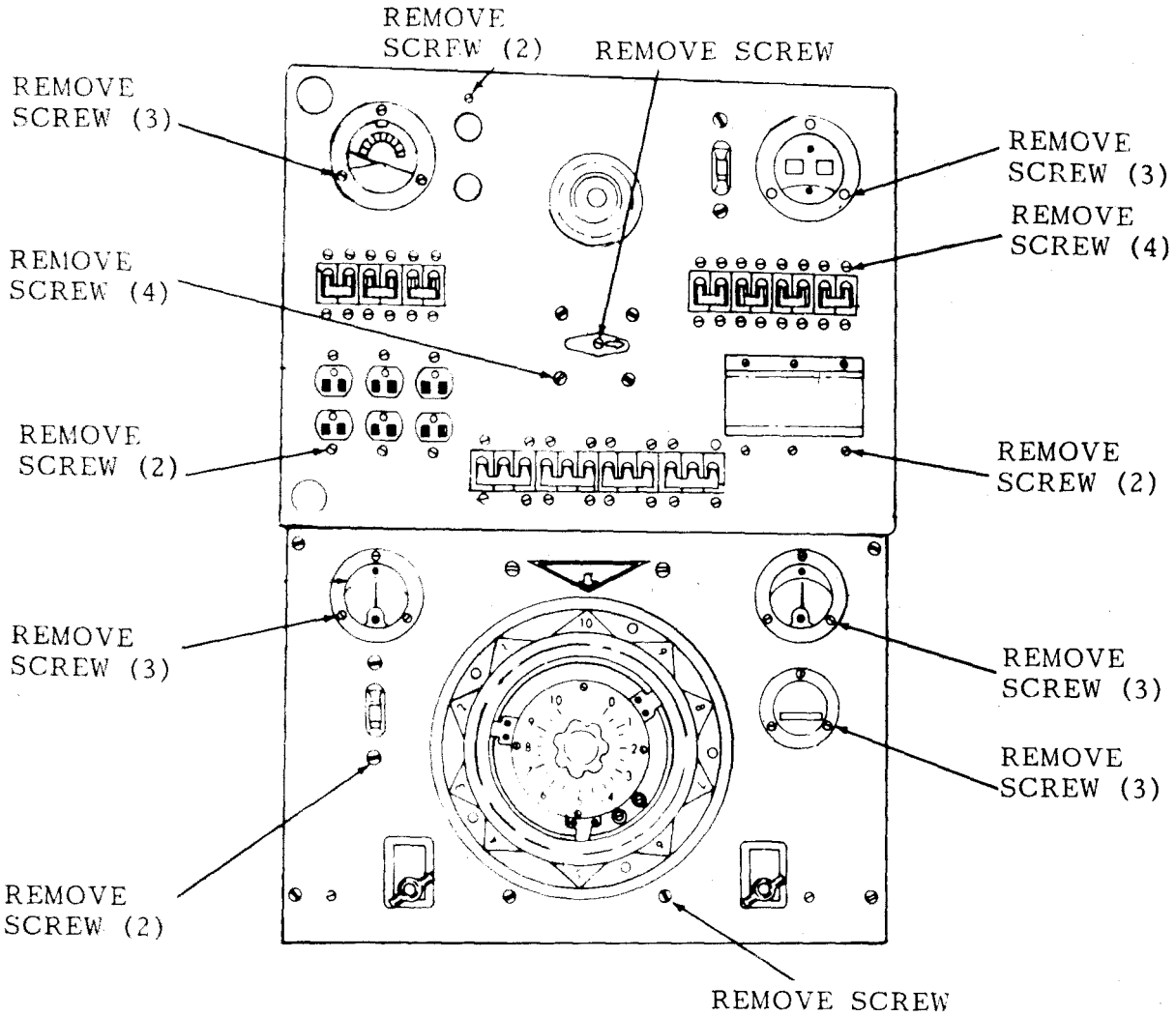
**18-7. WIRING (CONTROL CUBICLE).**

- a. General. When disconnecting wiring for maintenance, testing, repair, or replacement, always tag each wire or terminal for ready identification. The control cubicle wiring can be systematically checked out by reference to the schematic wiring diagrams.

**WARNING**

Before performing any maintenance procedures on the electrical system, see that all external power is disconnected from the shop set.

- b. Testing. Disconnect both ends of the wire under test. Touch the probes of a multimeter to each end of the wire. If the multimeter reading indicates an open circuit, replace the wire. Always use a wire of at least equal size.



NOTE: TAG AND DISCONNECT ELECTRICAL LEADS AS NECESSARY.

Figure 18-6. Dynamotor-Welder Control Panel.

### 18-8. ACVOLTMETER.

- a. Removal. Remove the AC voltmeter as illustrated in figure 18-6.
- b. Cleaning and Inspection.
  - (1) Clean the AC voltmeter with a clean, lint-free cloth.
  - (2) Inspect for broken glass, loose terminals, and other damage.
  - (3) Replace a defective AC voltmeter.
- c. Installation. Install the AC voltmeter as illustrated in figure 18-6.

### 18-9. DYNAMOTOR SWITCH.

- a. On-Equipment Testing.
  - (1) Tag and disconnect the leads from the switch.
  - (2) With the START button depressed, use a low-voltage test lamp to test between the switch terminals. Continuity should be indicated between the top two terminals only.
  - (3) Press the STOP button. Continuity should be indicated between the bottom terminals only.
  - (4) Replace a defective switch.
- b. Removal. Remove the dynamotor switch as illustrated in figure 18-6.
- c. Cleaning and Inspection.
  - (1) Clean with a clean, dry, lint-free cloth.
  - (2) Inspect for cracks, breaks, and loose terminals, and replace a defective switch.
- d. Installation. Install the dynamotor switch as illustrated in figure 18-6.

### 18-10. DC AMPERE ADJUSTING RHEOSTAT.

- a. Removal. Remove the DC ampere adjusting rheostat as illustrated in figure 18-6.
- b. Cleaning and Inspection.
  - (1) Clean with a clean, dry, lint-free cloth.
  - (2) Inspect for broken insulation, burnt wiring, and defects and loose terminals. Replace a defective rheostat.
  - (3) Test with a multimeter; graduated continuity should be indicated.



- c. Installation. Install the DC ampere adjusting rheostat as illustrated in figure 18-6.

#### 18-11. FREQUENCY METER.

- a. Removal. Remove the frequency meter as illustrated in figure 18-6.
- b. Cleaning and Inspection.
  - (1) Clean the frequency meter with a clean, dry, lint-free cloth.
  - (2) Inspect for damage and for loose terminals. Replace a defective frequency meter.
- c. Installation. Install the frequency meter as indicated in figure 18-6.

#### 18-12. FREQUENCY SWITCH.

- a. On-Equipment Testing.
  - (1) Tag and disconnect electrical leads from the frequency switch.
  - (2) Place switch in the 50-hertz position.
  - (3) Use a low-voltage test lamp circuit or a multimeter and test between the right upper terminal and its corresponding center terminal, Continuity should be indicated. Test between center and lower terminals. Continuity should not be indicated. Repeat this test on the upper left terminal.
  - (4) Place switch in the 60-hertz position and repeat the test in (3) above testing between the bottom and center terminals for continuity. Replace a defective switch.
- b. Removal. Remove the frequency switch as illustrated in figure 18-6.
- c. Cleaning and Inspection.
  - ( 1 ) Clean the switch with a clean, lint-free cloth.
  - (2) Inspect for defects and loose terminals and replace a defective frequency switch.
- d. Installation. Install the frequency switch as illustrated in figure 18-6.

#### 18-13. CIRCUIT BREAKERS (120 AND 240-VOLT).

- a. Removal. Remove the circuit breakers as illustrated in figure 18-6.

b. Cleaning and Inspection.

(1) Clean- circuit breakers with a clean, lint-free cloth.

(2) Inspect circuit breakers for cracks, loose terminals, and test for continuity across the terminals. Continuity should be indicated with the breaker ON, and not indicated with the breaker OFF.

c. Installation. Install the circuit breakers as illustrated in figure 18-6.

**18-14. RECEPTACLES.**

a. Removal. Remove the 120 and 240-volt receptacles as illustrated in figure 18-6.

b. Cleaning and Inspection.

(1) Clean the receptacles with a clean, lint-free cloth.

(2) Inspect for loose terminals and damage and replace a defective receptacle.

c. Installation. Install the receptacles as illustrated in figure 18-6.

**18-15. DC VOLTMETER.**

a. Removal. Remove the DC voltmeter as illustrated in figure 18-6.

b. Cleaning and Inspection.

(1) Clean voltmeter with a clean, lint-free cloth.

(2) Inspect voltmeter for damage and loose terminals and replace a defective voltmeter.

c. Installation. Install the DC voltmeter as illustrated in figure 18-6.

**18-16. RUNNING TIME METER.**

a. Removal. Remove the running time meter as illustrated in figure 18-6.

b. Cleaning and Inspection.

(1) Clean the running time meter with a clean, lint-free cloth.

(2) Inspect for damage and loose terminals, and replace a defective running time meter.

c. Installation. Install the running time meter as illustrated in figure 18-6.

**18-17. POLARITY SWITCH.**a. On-Equipment Testing.

- (1) Tag leads and note position of jumpers on polarity switch.
- (2) Disconnect leads and jumpers from the switch.
- (3) Place switch in OFF position.
- (4) Use a multimeter and test for continuity between each center terminal and all other terminals. No continuity should be indicated.
- (5) Place the switch in the STRAIGHT position.
- (6) Use a multimeter and test between each center terminal and its corresponding lower terminal. Continuity should be indicated. Then test between each center terminal and its corresponding upper terminal. No continuity should be indicated.
- (7) Place the switch in REVERSE position.
- (8) Repeat tests as in (6) above. Continuity should not be indicated between the center and lower terminals. Continuity should be indicated between the center and upper terminals.
- (9) Replace a defective switch.

b. Removal. Remove the polarity switch as illustrated in figure 18-6.

c. Cleaning and Inspection.

- (1) Clean the switch with a clean, lint-free cloth.
- (2) Inspect for damage and loose terminals and replace a defective polarity switch.

d. Installation. Install the polarity switch as illustrated in figure 18-6.

**18-18. DC AMMETER.**

a. Removal. Remove the DC ammeter as illustrated in figure 18-6.

b. Cleaning and Inspection.

- (1) Clean the direct current ammeter with a clean, dry, lint-free cloth .
- (2) Inspect for damage and loose terminals. Replace a defective ammeter.

c. Installation. Install the DC ammeter as illustrated in figure 18-6.

**18-19. AC VOLTAGE ADJUSTING RHEOSTAT.**

- a. Removal. Remove the rheostat as illustrated in figure 18-6.
- b. Testing. Use a multimeter and test the rheostat and the direct current resistance element for smooth operation through out the range. Test the rheostat for resistance of 121.5 plus or minus 5 percent. Replace a defective rheostat.
- c. Cleaning. Wipe clean using a lint-tree rag.
- d. Installation. Install the rheostat as illustrated in figure 18-6. Refer to schematic wiring diagrams.

**18-20. CONTROL CABINET.**

- a. Disassembly. Disassemble the control cabinet as illustrated in figures 18-7, 18-8, and 18-9.
- b. Assembly. Assemble the control cabinet as illustrated in figures 18-7, 18-18, and 18-9.

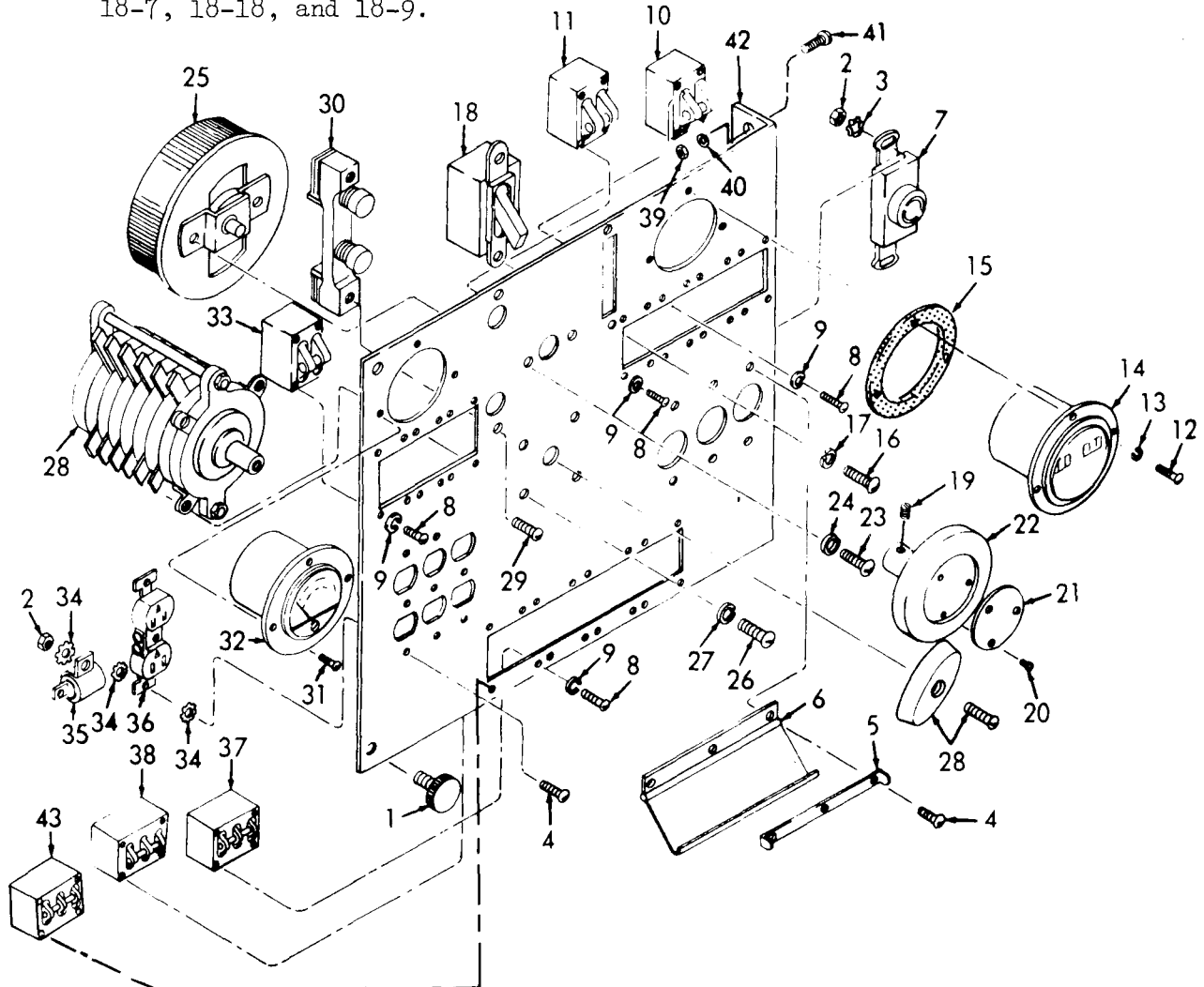
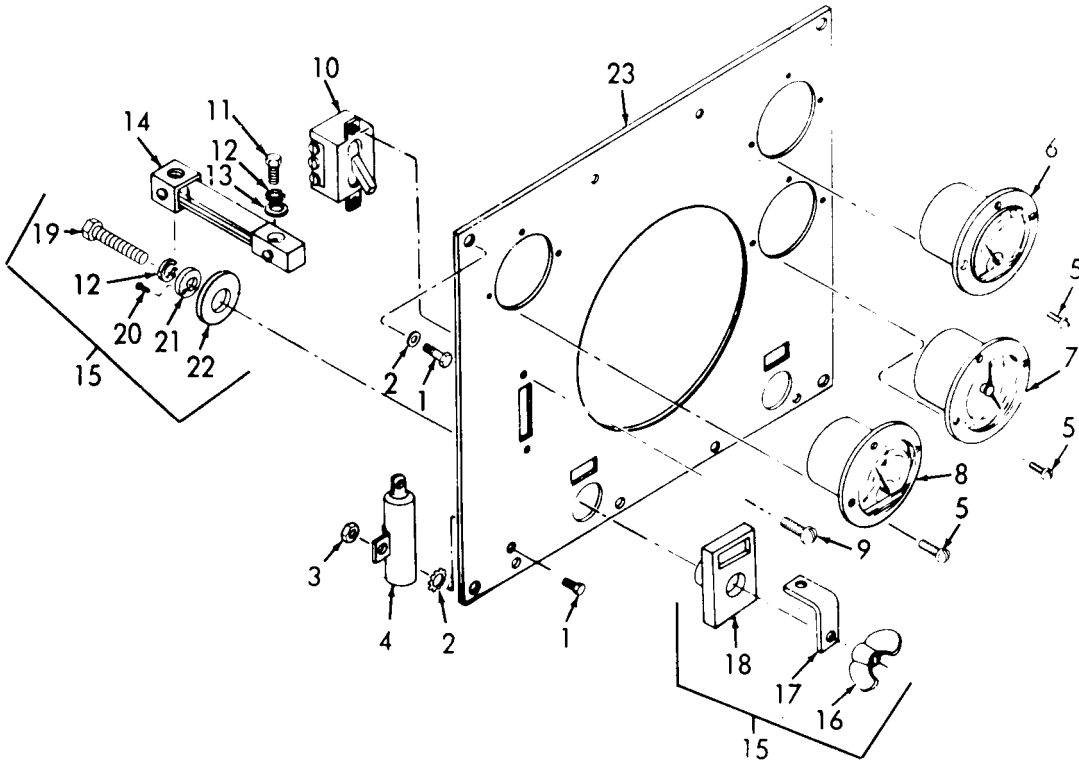


Figure 18-7. Upper Control Panel.

## LEGEND FOR FIGURE 18-7:

ITEM	NSN	P/N	FSCM	QTY
1. Knob	5355-00-959-7853	16DW1148	28835	2
2. Nut, Plain	5310-00-934-9757	MS35649-262	96906	12
3. Washer, Flat	5310-00-765-2085	W11245-2	28835	6
4. Screw, Machine	5305-00-047-0970	W11111-3	28835	12
5. Stop		16DW1145	28835	1
6. Cover, Recep.		88W1448	28835	1
7. Receptacle	5935-00-928-8116	WC596G1	81348	3
8. Screw, Machine	5305-01-057-6675	W11110-1	28835	44
9. Washer, Lock	5310-00-889-2708	MS45904-54	96906	44
10. Circuit Breaker	5925-00-318-0026	M55629/3-031	81349	1
11. Circuit Breaker	5925-00-595-8846	M55629/3-080	81349	3
12. Screw	5305-01-056-1508	W11220-1	28835	3
13. Washer, Lock	5310-00-060-9435	MS35338-35	96906	3
14. Meter, Electrical	6625-00-842-0897	30PHXXRUG	31356	1
15. Gasket, Meter		GSK2	31356	1
16. Screw	5305-00-052-6920	MS24629-56	96906	2
17. Washer, Lock	5310-00-889-2528	MS45904-68	96906	2
18. Switch, Toggle	5930-00-549-0310	80975	04009	1
19. Setscrew	5305-00-724-6736	MS51965-52	96906	1
20. Screw, Drive	5305-00-253-5617	MS21318-23	96906	3
21. Plate, Ident	9905-00-074-8085	12CW1172	28835	1
22. Resistor	5950-00-447-4206	AW72 9	28835	1
23. Screw, Machine	5305-00-004-1553	W11114-4	28835	2
24. Washer, Lock	5310-00-550-1130	MS35333-40	96906	2
25. Resistor Variable	5905-00-434-2611	BW161A	28835	1
26. Screw	5305-00-052-8905	MS24630-59	96906	4
27. Washer, Lock	5310-00-839-2528	MS45904-68	96906	4
28. Switch, Toggle	5930-00-735-9067	16DW892	28835	1
29. Screw	5305-01-056-3188	W11221-2	28835	2
30. Switch, Push	5930-00-759-8345	25MS279-2	28835	1
31. Screw	5305-01-056-1508	W11220-1	28835	3
32. Voltmeter	6625-00-845-0606	30749	15309	1
33. Circuit Breaker	5925-00-443-9478	M55629/3-119	81349	3
34. Washer, Lock	5310-00-261-6192	4008-14-00	78189	9
35. Capacitor, Fixed	5910-00-367-7862	B206132	76149	3
36. Connector Receptacle	5935-01-012-3080	5252	74545	3
37. Circuit Breaker	5925-00-443-9478	M55629/5-094	81349	1
38. Circuit Breaker	5925-00-272-8898	M55629/5-115	81349	2
39. Nut, Hex	5310-00-851-2675	MS28691-1	96906	7
40. Washer, Lock	5310-00-637-9575	4014-20-00	78189	7
41. Screw, Machine	5305-01-039-0229	W11114-2	28835	7
42. Panel, Hinged		16DW1127	28835	1
43. Circuit Breaker	5925-01-086-6008	M55629/5-241	81349	1



LEGEND FOR FIGURE 18-8:

ITEM	NSN	P/N	FSCM	QTY
1. Screw, Machine	5305-00-988-1723	MS35206-279	96906	8
2. Washer, Lock	5310-00-889-2528	MS45904-68	96906	8
3. Nut, Plain	5310-00-834-8736	MS35691-2	96906	4
4. Capacitor, Fixed	5910-00-367-7862	CA37KFW254	81349	2
5. Screw	5305-00-053-1114	MS24621-11	96906	9
6. Voltmeter, DC	6625-00-842-0898	W8703-12	28835	1
7. Meter, Time	6645-00-864-6794	M3602	74400	1
8. Ammeter, DC	6625-00-842-0896	W8062-11	28835	1
9. Screw	5305-00-067-9896	MS24621-55	96906	2
10. Switch, Toggle	5930-00-272-1362	80634	04009	1
11. Screw, Cap	5305-00-071-2240	MS90725-11	96906	4
12. Washer, Lock	5310-00-584-5272	MS35338-48	96906	6
13. Washer, Flat	5310-00-809-5998	MS27183-16	96906	4
14. Shunt	6625-00-272-9885	CW1142A	28835	1
15. Connector		50W985-2	28835	2
16. Nut, Plain	5310-00-823-8756	MS35425-44	96906	2
17. Terminal		5CW574	28835	2
18. Insulator	5970-00-698-7191	5CW-975	28835	2
19. Screw, Cap	5305-00-769-2217	351505	28835	2
20. Screw, Machine	5305-00-984-4982	MS35206-225	96906	2
21. Insulator	5970-01-037-8911	5CW976A	28835	2
22. Washer, Flat	5310-00-809-3079	MS27183-19	96906	2
23. Panel	3431-00-784-2782	16DW1128	28835	1

Figure 18-8. Lower Control Panel.

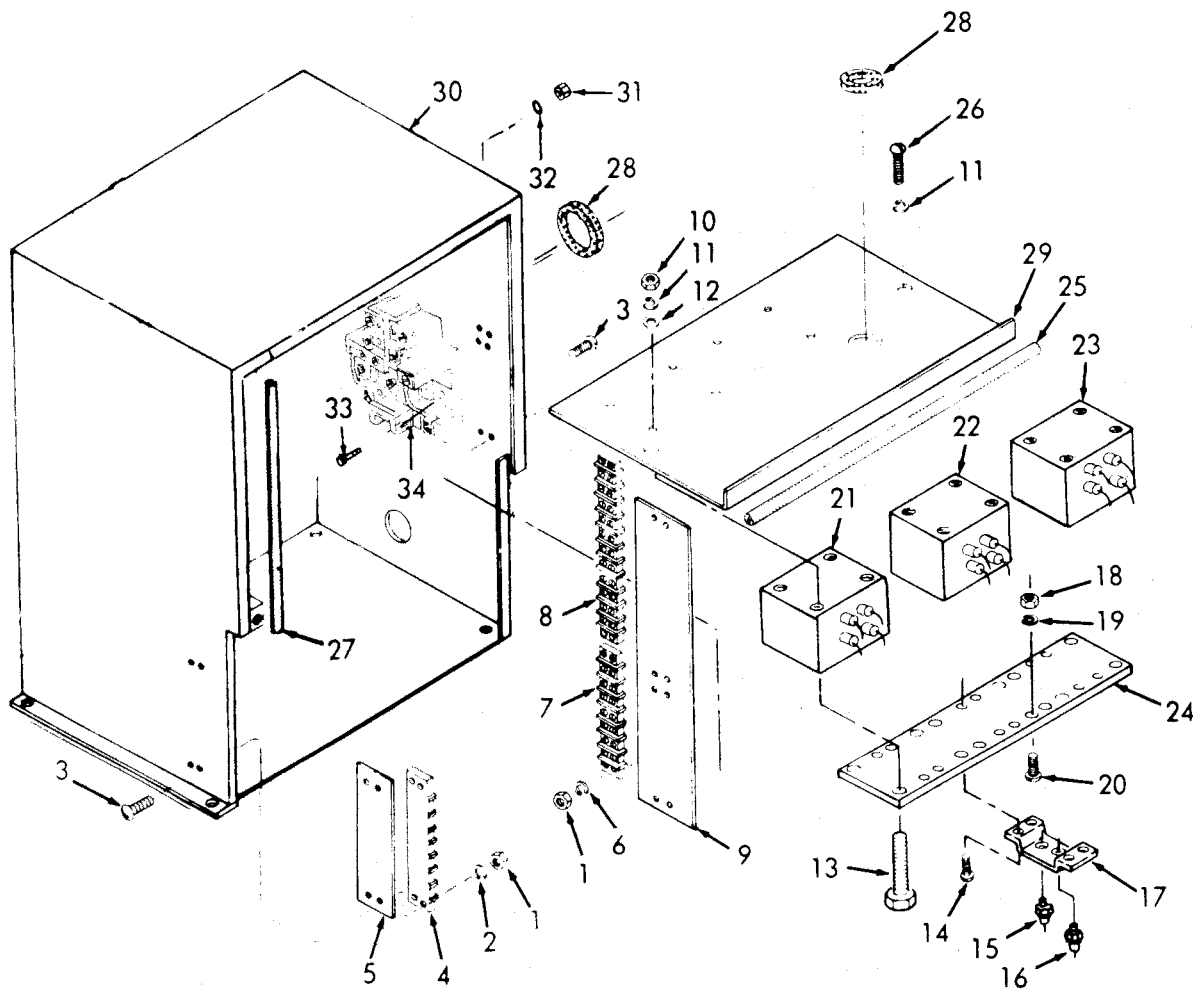


Figure 18-9. Control Box and Coil Assembly, Removal and Installation.

## LEGEND FOR FIGURE 18-9:

ITEM	NSN	P/N	FSCM	QTY
1. Nut, Self-Locking	5310-00-208-1918	MS35649-282	96906	12
2. Washer, Lock	5310-00-707-0694	W11254-2	28835	4
3. Setscrew	5305-01-047-0968	W11111-8	28835	12
4. Terminal, Board	5940-00-779-3805	206	38151	1
5. Plate, Ident	9905-00-074-3087	8BW1593	28835	1
6. Washer, Lock	5310-00-460-4135	W11254-12	28835	8
7. Strip, Terminal		308	38151	1
8. Strip, Terminal		312	38151	1
9. Plate, Ident		16DW1166	28835	1
10. Nut, Plain	5310-00-851-2675	MS35691-1	96906	12
11. Washer, Lock	5310-00-487-1289	W11254-4	28835	14
12. Washer, Flat	5310-00-480-4143	W11242-5	28835	12
13. Screw, Cap	5305-00-869-5026	402119-12	28835	12
14. Screw, Tapping	5305-00-058-1082	MS51861-34	96906	12
15. Semiconductor, Device	5961-00-922-4817	2RT352-1	41852	3
16. Semiconductor, Device	5961-00-922-4818	2RT353-1	41843	3
17. Sink, Heat	5999-00-435-8478	16DW1319	28835	3
18. Nut, Stamped	5310-01-055-3841	T0632005	77122	2
19. Washer, Lock	5310-01-039-0241	W11254-1	28835	4
20. Screw, Machine	5305-01-040-0999	W11110-7	28835	4
21. Transformer	5950-00-434-2618	358869-3	28835	1
22. Transformer	5950-00-434-2632	358869-2	28835	1
23. Transformer	5950-00-434-2626	358869-1	28835	1
24. Terminal Board	5940-00-434-4842	16DW1321	28835	1
25. Rubber Round	5330-01-099-0191	20-849CCV	02231	2
26. Screw, Cap	5305-00-869-5013	402119-4	28835	2
27. Gasket	5370-01-099-0919	20-849CCV	02231	2
28. Grommet, Nonmetallic	5325-00-824-5277	MS35489-129	96906	3
29. Tray, Cubicle	3431-00-764-2671	16DW1120	28835	1
30. Box, Cubicle		1DW1106-2	28835	1
31. Nut, Hexagon	5310-00-934-9758	MS35649-202	96906	2
32. Washer, Lock	5310-00-045-3296	MS35338-43	96906	2
33. Screw, Machine	5305-00-984-6212	MS35206-265	96906	2
34. Relay, Electro- Magnetic	5945-00-500-5997	PRD7DHO-24V	77342	1



**18-21. ENGINE INSTRUMENTS AND CONTROLS.**

- a. Removal. Refer to figures 18-10 and 18-11 for the removal of the right hand side and left hand side engine control panels.
- b. Installation. Refer to figures 18-10 and 18-11 for the installation of the right hand side and left hand side engine control panels.

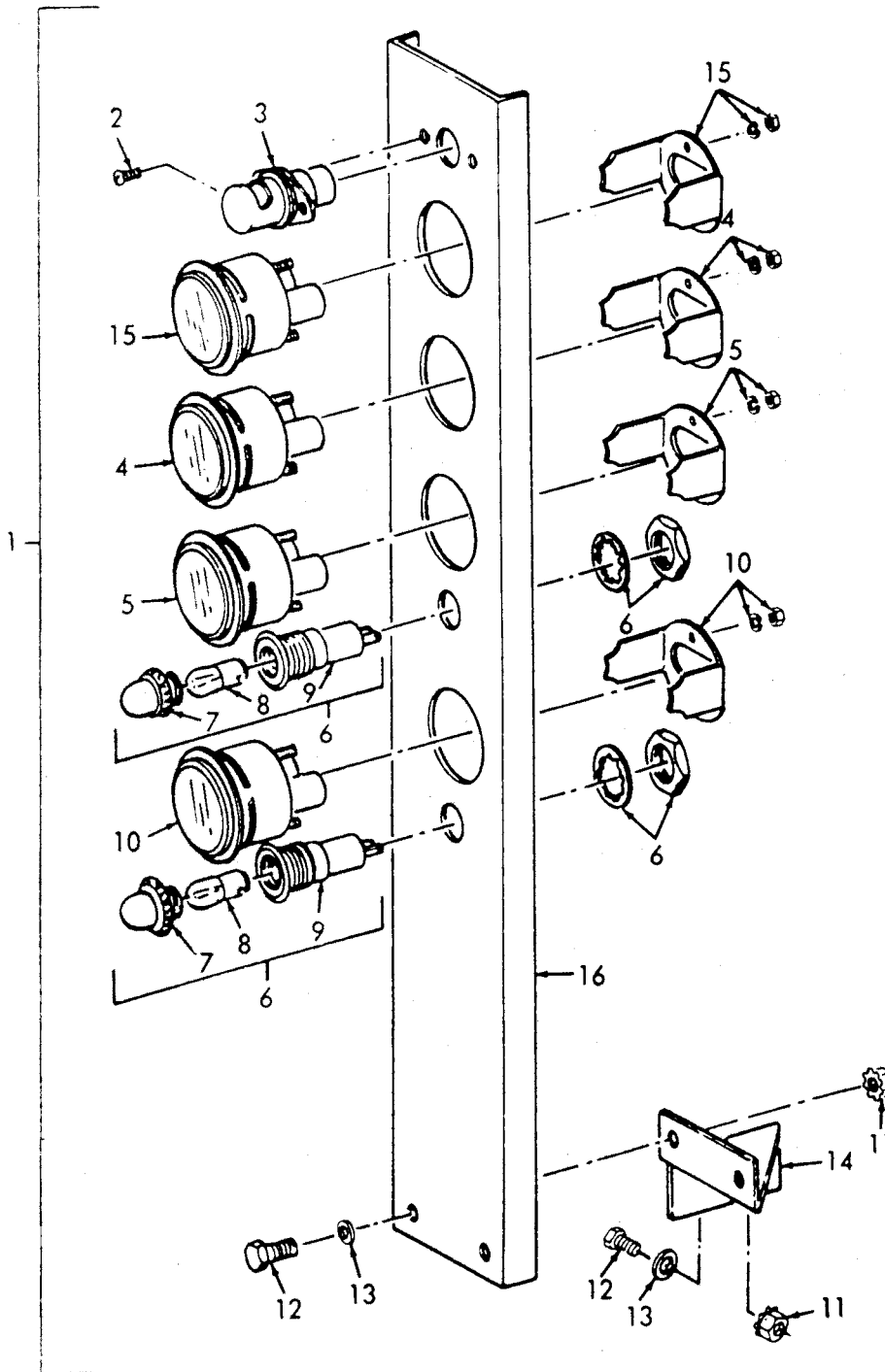


Figure 18-10. Engine Control Panel, Right Hand.

## LEGEND FOR FIGURE 18-10:

ITEM	NSN	P/N	FSCM	QTY
1. Panel Assy, RH		358946	28835	1
2. Screw	5305-00-053-1114	MS24621-11	96906	2
3. Light, Panel	6210-01-071-9281	30GH1262	28835	1
4. Meter	6625-00-321-6365	MS24532-2	96906	1
5. Gage, Temperature	6685-00-936-2139	MS24543-2	96906	1
6. Light Assy, Warn.		LH75	28265	2
7. Lens, Red, Warn.		LC15RD	81349	2
8. Lamp, Incandescent	6240-00-155-8714	MS15571-4	96906	2
9. Body, Light		LH7613	81349	2
10. Indicator, Pressure	6620-00-938-8212	MS24541-1	96906	1
11. Nut, Plain	5310-00-834-8736	MS35691-2	96906	4
12. Screw, Cap	5305-00-068-0500	MS90725-3	96906	4
13. Washer, Flat	5310-00-809-4058	MS27183-10	96906	4
14. Washer		354177	28835	1
15. Indicator, Liquid	6680-00-933-3600	7728852	19207	1
16. Panel, RH		353476	28835	

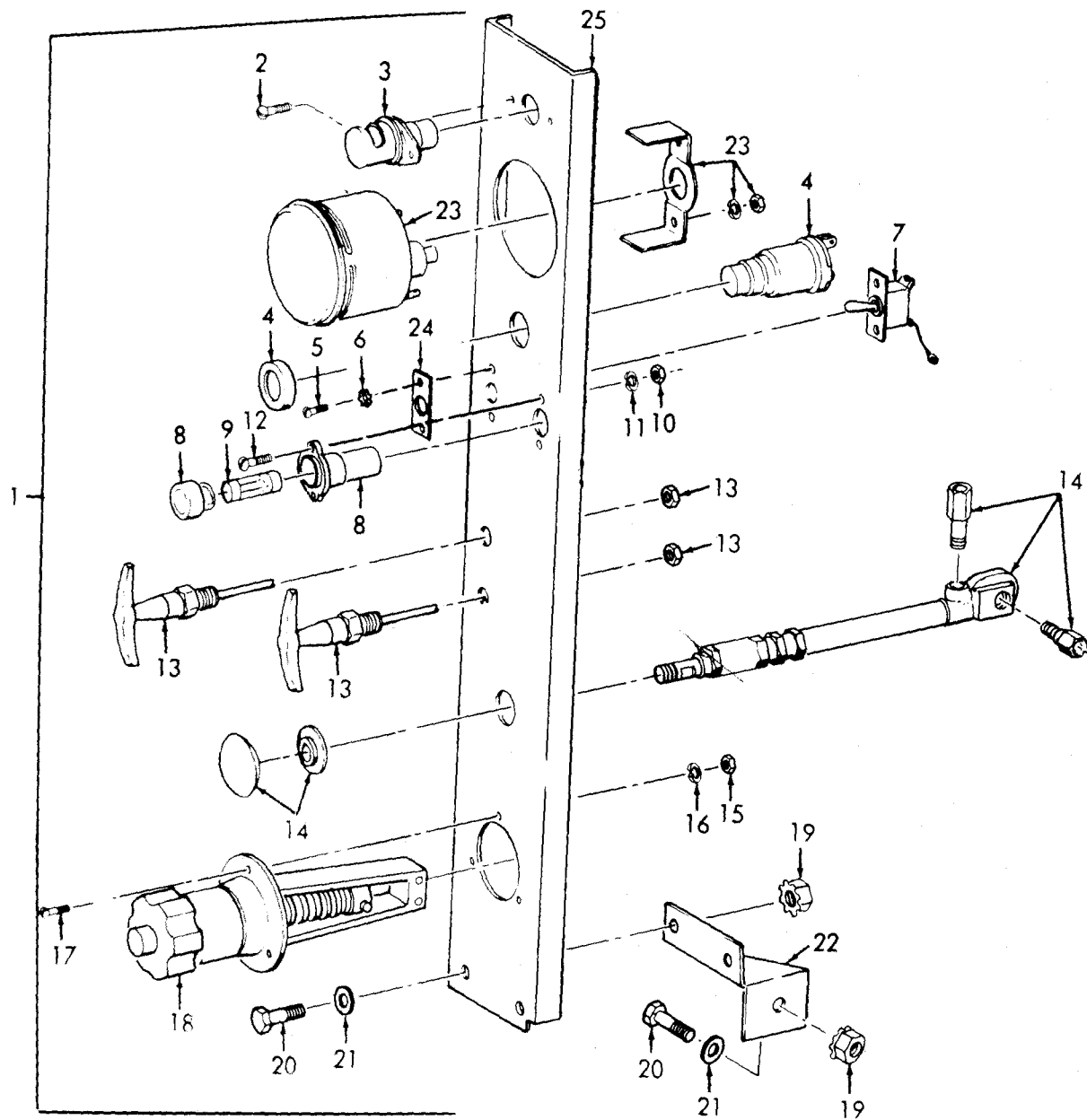


Figure 18-11. Engine Control Panel, Left Hand.

## LEGEND FOR FIGURE 18-11:

ITEM	NSN	P/N	FSCM	QTY
1. Light Panel	6210-01-071-9281	358719	28265	1
2. Screw, Tapping	5835-00-053-1114	MS24621	96906	2
3. Light, Panel	6210-01-071-9281	30GH1262	28835	1
4. Key, Lock		5552	83064	1
5. Screw, Machine	5305-00-984-4988	MS35206-228	96906	2
6. Washer, Lock	5310-00-209-0788	MS35335-30	96906	2
7. Switch, Toggle	5930-00-278-7731	81402	04309	1
8. Fuseholder		HPCCK	71400	1
9. Fuse, Cartridge	5920-00-688-4085	FNM10	71400	1
10. Nut, Plain	5310-00-934-9757	MS35649-282	96906	2
11. Washer, Lock	5310-00-045-3299	MS35338-42	96906	2
12. Screw, Machine	5305-00-984-6193	MS35206	96906	2
13. Control, Throttle		208569A	28265	2
14. Switch, Push	2920-00-096-9202	53022	28265	1
15. Nut, Plain	5310-00-934-9758	MS35649-202	96906	3
16. Washer, Lock	5310-00-045-3296	MS35338-43	96906	3
17. Screw, Machine	5305-00-984-6210	MS35205-263	96906	3
18. Control Assy.		1012-03576-80	51377	1
19. Nut, Plain	5310-00-834-8736	MS35691-2	96906	2
20. Screw, Cap	5305-00-068-0500	MS90725-3	96906	2
21. Washer, Flat	5310-00-809-4058	MS27183-10	96906	2
22. Gusset		354177	28265	1
23. Tachometer	6680-00-825-2076	MS35916-2	96906	1
24. Plate, Instruc.		201913A	28265	1
25. Panel, Control		358720	28835	1

## CHAPTER 19

### TRAILER CHASSIS AND COMPONENTS

---

**19-1. GENERAL.** The trailer chassis is specially made for this shop set. It consists of a 36,000-lb. capacity, dual-tandem axle assembly, air over hydraulic braking system, and a manually operated mechanical retracting landing gear assembly. The trailer is electrically wired to the front and rear intervehicular receptacles to transmit 24-volt DC current from the towing vehicle to the taillights and clearance lights on the shop set body.

#### **19-2. WHEELS AND BRAKE SYSTEM.**

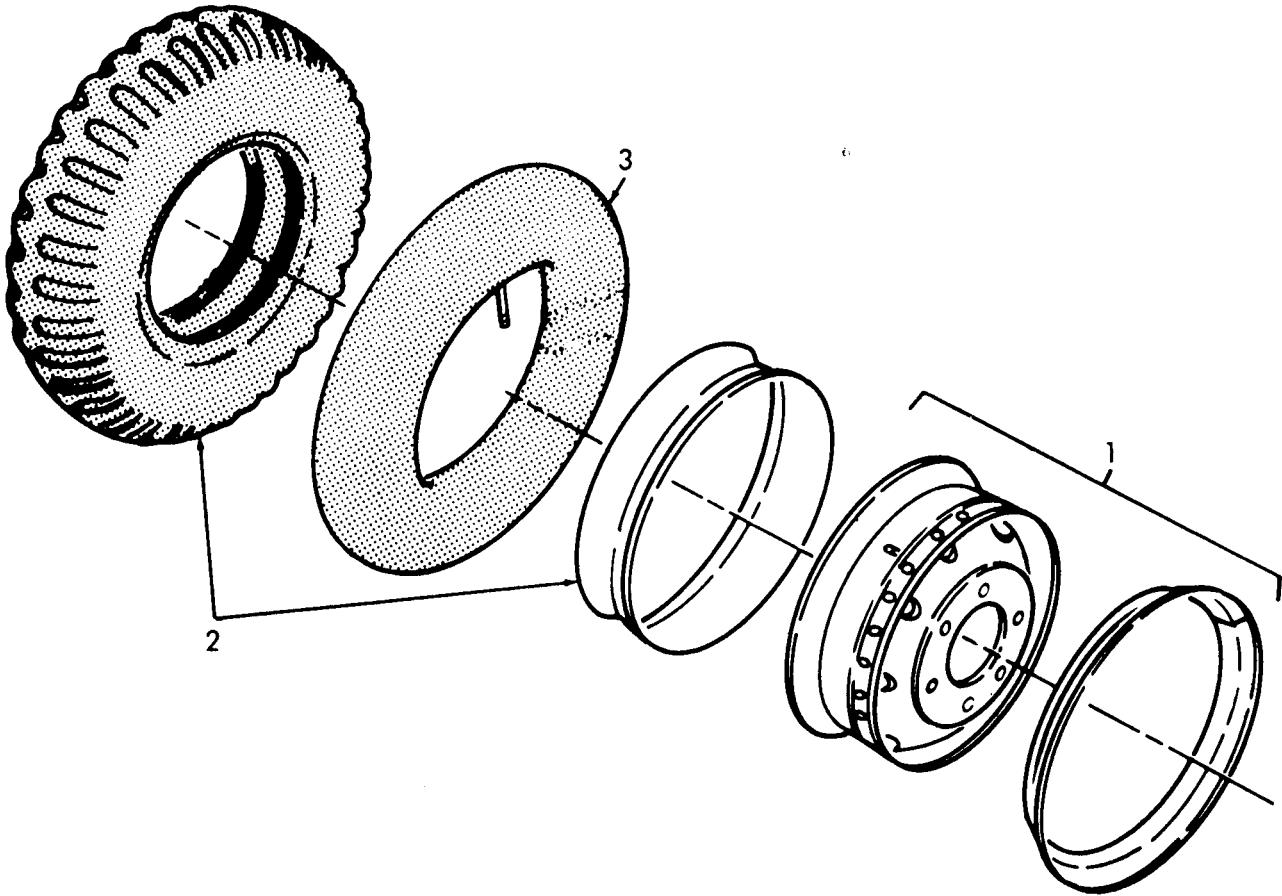
General. The trailer rides on two sets of dual wheels and is stopped by air over hydraulic brakes actuated by air supplied from the towing vehicle or cab. The air reservoir stores air received from the towing vehicle for operating the air-hydraulic cylinders. During normal operation, the air pressure in the air reservoir will be the same as the towing vehicle reservoir. The braking system uses a dual-purpose valve called "emergency relay valve". It directs air pressure to the air-hydraulic cylinders when the brakes are applied, and will automatically set the trailer brakes if the trailer becomes separated from the towing vehicle.

#### **19-3. TESTING AIRBRAKE SYSTEM FOR LEAKS.**

- a. Dry Test. Connect the trailer brake system to the towing vehicle brake system. Make sure the towing vehicles brake system is in good condition. Charge both systems to 100 psi with the air compressor and turn off the engine. Without applying the brakes, the drop in air pressure should not exceed three pounds per minute. Apply the brakes fully and observe the drop in pressure. The rate should not exceed four pounds per minute. If air leakage is excessive, isolate the defective component by following the test procedure in b, below.
- b. Wet Test. Apply a liquid soap solution to the brake system components and connections with a brush. Observe for signs of leakage when the brakes are fully applied and when they are released. To inspect the emergency-relay valve for leakage in the emergency position, shut off the vehicles's emergency line and disconnect it from the trailer. Inspect for leakage at the emergency relay valve.

#### **NOTE**

If leaks are at connection points, tighten the connections. Repair or replace defective components. Report uncorrected deficiencies to direct support maintenance.



LEGEND FOR FIGURE 19-1:

ITEM	NSN	P/N	FSCM	QTY
1. Wheel		MS53044-6	96906	8
2. Tire		MS35338-21	96906	8
3. Inner Tube	2610-00-051-9450	MS35392-15	96906	8

Figure 19-1. Tire and Rim.

**19-4. TIRES AND WHEELS MAINTENANCE.**

- a. Disassembly. Disassemble the wheels and tires as illustrated in figure 19-1,
- b. Cleaning, Inspection, and Repair.
  - (1) Scrape dirt from wheels.
  - (2) Inspect studs for wear, cracks, stripped threads, burrs, and any other damage.
  - (3) Damage will occur to the wheel if the mounting nuts become loose, resulting in excessive wear on the wheel mounting holes. If the wheel mounting holes have become enlarged because of excessive wear, replace the wheel.
  - (4) Inspect tires for cuts, bruises, wear, deteriorated cords, and other obvious damage.
  - (5) Inspect wheel lockrings for cracks, breaks, or bends. Replace as necessary.
  - (6) Replace any excessively worn or defective tires, tubes, wheels, or related components.
  - (7) Clean the rubber flaps and inspect for defects. Replace a defective flap.
  - (8) For more detailed repair of tires, refer to TM 9-2610-200-20.
- c. Tire Matching. Measure the circumference of the tires of one dual assembly at the center of the tread. Tires must match within three-quarter inch of their circumference and one-quarter inch of their diameter. Always mount the larger of the dual tires on the outside wheel.
- d. Reassembly. Reassemble the wheels and tires as illustrated in figure 19-1.
- e. Installation.
  - (1) Place the inner wheel on the hub studs and secure with the five inner wheel nuts. Alternately tighten the nuts on the opposite sides to assure tightness. Place the outer wheel over the inner wheel nuts in such a manner that the valve stem of the outer tire is as near to 180° from the inner valve stem as possible, and that the holes in the body of the inner and outer wheel are lined tip. Install the five outer wheel nuts and tighten alternately.
  - (2) Lower the trailer and release brakes.

## NOTE

If the outer nut is tightened on a loose inner nut and the inner nut becomes loose, the outer nut is difficult to remove.

### 19-5. HUB BREAKDOWN AND WHEEL BEARINGS.

- a. General. The hub supports the dual wheels mounted to the hub flange. Each hub is mounted on the axle spindle by means of two tapered roller bearings equipped with grease seal, spindle nuts for adjustment purposes, and hub caps.
- b. Removal and Disassembly.
  - (1) Remove the wheels.
  - (2) Disconnect air lines from the towing vehicle and open draincock on the trailer air reservoir tank to be sure brakes are fully released with no contact between the brake shoes and the brake drum.
  - (3) Remove the hub, brake drum, and bearings, as illustrated in figure 19-2.
- c. Cleaning, Inspection, Lubrication and Repair.
  - (1) Wash all parts in cleaning solvent and dry thoroughly, removing all old grease from wheel bearings.
  - (2) Inspect hub and brake drum for cracks, scoring, overheating, and out-of-round condition. Replace hub and brake drum if out-of-round exceeds 0.010 inch.
  - (3) Inspect all parts for wear and defects. Inspect bearing cones and rollers for pitting, chipping, and broken rollers.
  - (4) Replace worn and defective parts.
  - (5) Pack wheel bearings by kneading lubricant into all the openings and completely filling all spaces in the cones.
- d. Reassembly and Installation.
  - (1) Install the hub brake drum assembly in reverse order of b.
  - (2) Adjust wheel bearings as instructed in e.
  - (3) Close draincock on the air reservoir and connect the lines to the towing vehicle.
  - (4) Install the wheels.



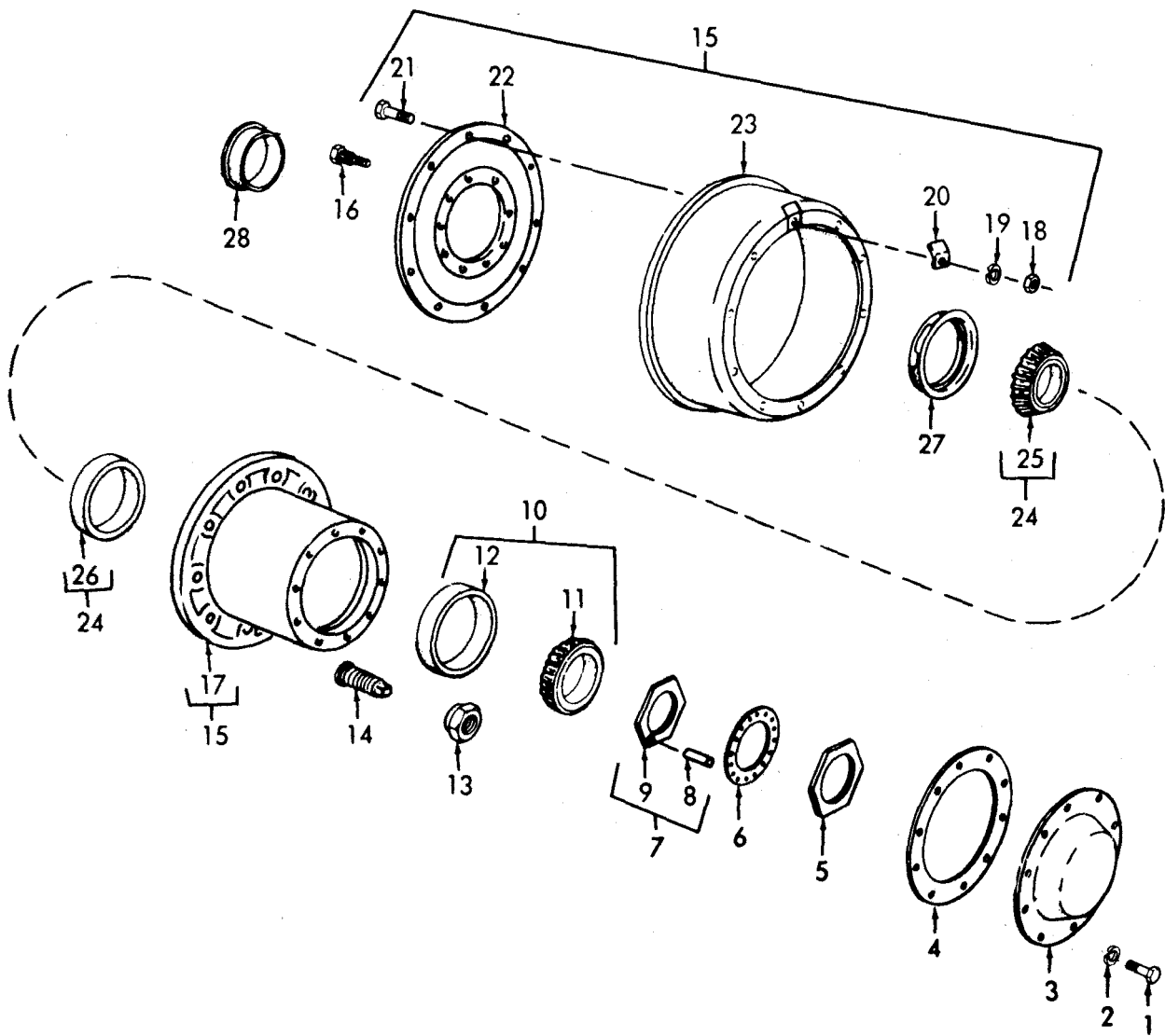


Figure 19-2. Hub and Drum.

## LEGEND FOR FIGURE 19-2:

ITEM	NSN	P/N	FSCM	QTY
1. Bolt, Machine	5306-00-225-8494	MS90725-29	96906	12
2. Washer, Lock	5310-00-407-9566	MS35338-45	96906	12
3. Cap, Hub		8710725	19207	2
4. Gasket, Hub Cap	5330-00-290-8521	8710726	19207	2
5. Nut, Bearing		7979263	19207	2
6. Washer, Bearing		5139123	19207	2
7. Nut, Adjusting		7979308	19207	2
8. Pin		7979310	19207	1
9. Nut		7979309	19207	1
10. Bearing, Roller	3110-00-100-4221	MS19081-142	96906	2
11. Cone, Bearing		705155	12742	1
12. Cup, Bearing		706691	19207	1
13. Nut, Wheel, Outer RH	5310-00-500-0387	537805	19207	10
13. Nut, Wheel, Outer LH	5310-00-880-2004	MS51983-3	96906	10
14. Nut, Wheel, Inner, LH		537810	19207	10
14. Nut, Wheel, Inner, RH	2530-00-693-1029	537809	19207	10
15. Hub & Drum Assy, RH		8710722	19207	1
15. Hub & Drum Assy, LH		8710721	19207	1
16. Bolt, Ribbed	5306-00-383-4957	MS51946-2	96906	10
16. Stud, Wheel, LH		MS51946-1	96906	10
17. Hub		8710723	19207	1
18. Nut, Plain	5310-00-989-5944	MS51972-4	96906	10
19. Washer, Lock	5310-00-209-0965	MS35338-47	96906	10
20. Adapter		8710724	19207	1
21. Bolt, Machine	5306-01-062-2334	7979179	19207	10
22. Cover		7979315	19207	1
23. Drum		7979233	19207	1
24. Bearing, Roller	3110-00-100-4220	MS19081-137	96906	2
25. Cone, Bearing		712286	19207	1
26. Cup, Bearing		706691	19207	1
27. Seal, Oil	5330-00-740-9553	7979349	19207	2
28. Ring, Wiper, Oil Seal	2530-00-740-9553	7409553	19207	2

e. Wheel Bearing Adjustment.

- (1) Remove the hub cap (3, figure 19-2), gasket (4), nut (5), and washer (6).
- (2) Use a wrench and tighten the adjusting nut (7), while turning hub and brake drum, until hub and brake drum bind. Then back off adjusting nut slightly until hub and brake drum turn freely.
- (3) Place the washer (6) on the axle shaft next to the adjusting nut (7). If one of the holes on the washer is not aligned with the pin on the inner adjusting nut, remove the washer and reinsert it in the inverted position. If a hole still does not align with the pin, the inner adjusting nut (7) must be turned counterclockwise so that the nearest hole in the washer is lined up. Then, install the adjustment locking nut (5), gasket (4), and cap (3), and secure with six washers (2), and screws (1).
- (4) Adjust other wheel bearings in the same manner.

**19-6. BRAKE ADJUSTMENT.**

- a. Following overhaul or when new linings are installed, the initial adjustment should be carefully made to properly locate the curvature of the lining to the drum and to obtain the proper clearance.
- b. Each shoe must be adjusted to center the brake shoe arc in relation to the drum.
- c. Turn the adjusting screws (fig. 19-3) to bring lining into contact with the drum and rotate the anchor pin sufficiently to relieve drag. Repeat until additional rotation of anchor pin will no longer relieve drag.
- d. Lock anchor pin locknut and back off adjusting screw to permit wheel to turn freely.

**NOTE**

Turn the adjusting screw on the left side of the bleeder screw in a counterclockwise direction to bring the lining into contact with the drum. Turn the adjusting screw to the right of the bleeder screw, clockwise, to bring the other lining into contact with the drum.

- e. Subsequent adjustments to compensate for lining wear are made by turning the adjusting screws to bring linings into contact with the drum. Back off sufficiently to permit free rolling drum.

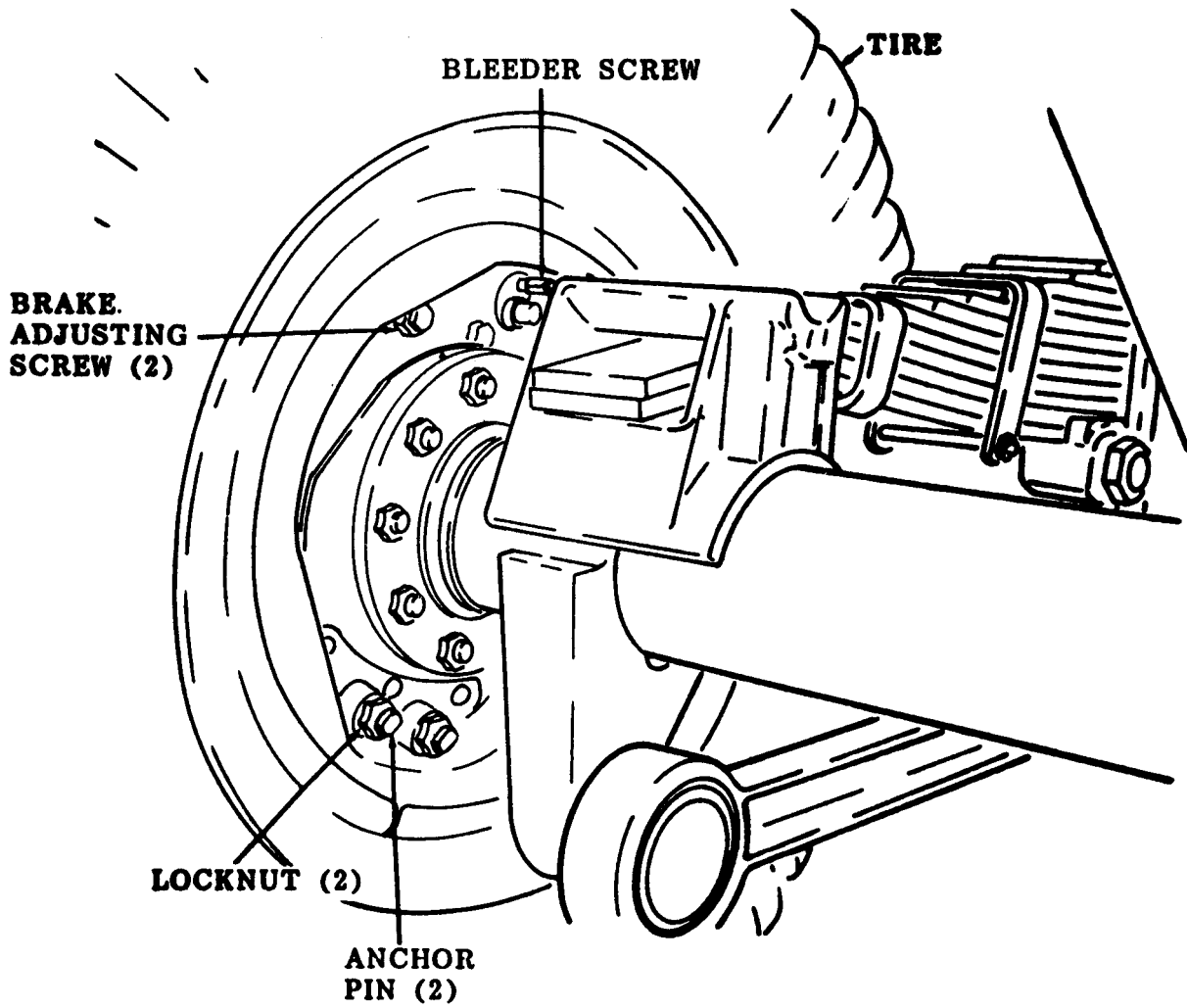


Figure 19-3. Brake Adjustment.

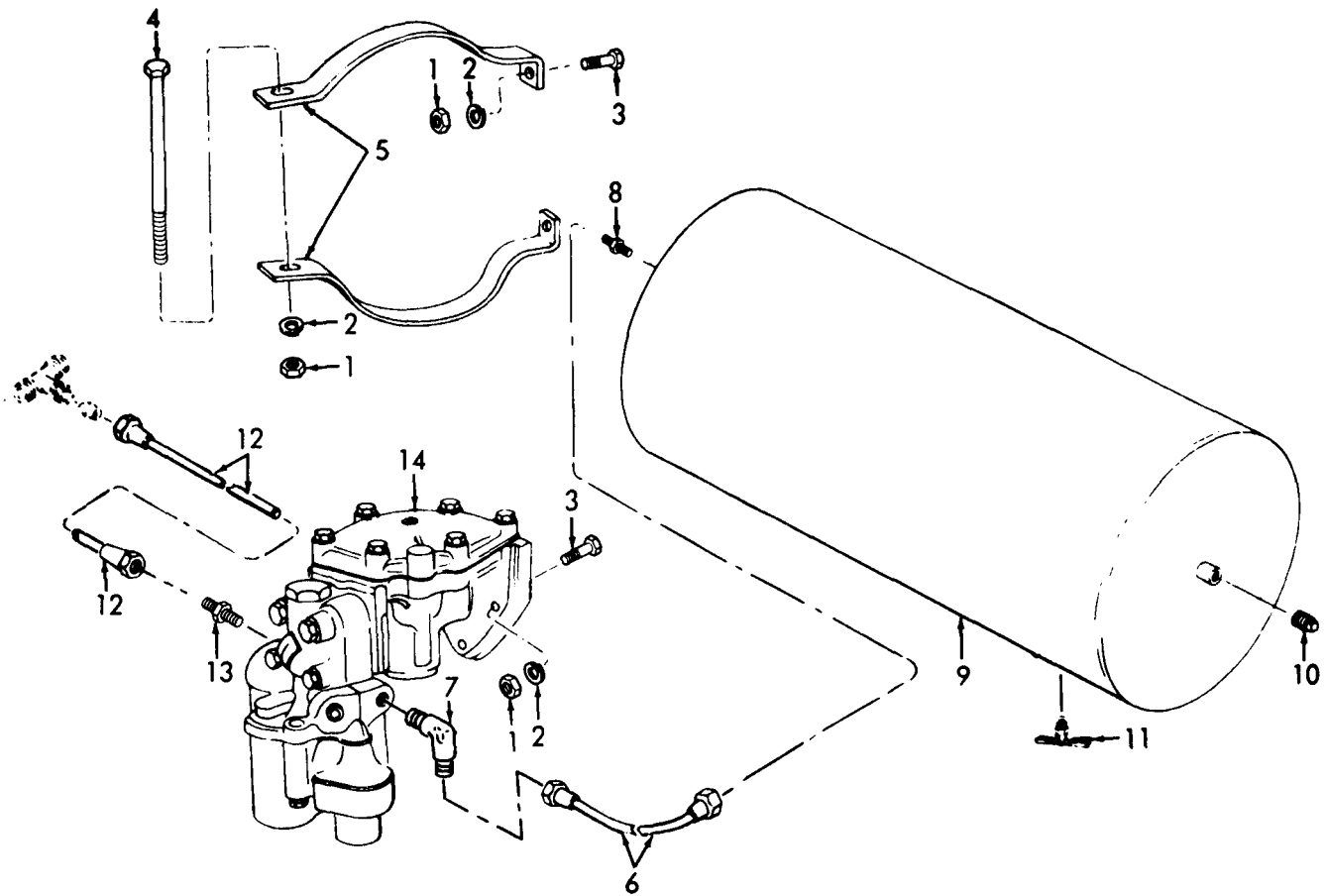
- f. With brakes released, insert a small rod through hole in brake air chamber, below hydraulic cylinder. Mark rod at surface of mounting bracket when rod contacts push rod in brake air chamber. Apply brakes and again mark rod at surface of mounting bracket with rod in contact with push rod. Withdraw rod and measure distance between marks which will indicate amount of push rod travel. Brakes should be adjusted to permit a minimum of 1/2-inch travel and a maximum of 7/8-inch travel. Adjust service brakes if necessary.

#### 19-7. EMERGENCY RELAY VALVE.

- a. Removal. Remove the emergency relay valve as illustrated in figure 19-4.
- b. Cleaning and Inspection.
- (1) Clean with cleaning solvent and dry thoroughly.
  - (2) Inspect for defects and damage to valve. Inspect lines for crimps, breaks, or other defects. Replace defective valve or lines.
- c. Installation. Install the emergency relay valve as illustrated in figure 19-4.

#### 19-8. AIR RESERVOIR TANK.

- a. Removal.
- (1) Open draincock (11, figure 19-4), and remove the draincock from the tank (9).
  - (2) Disconnect the lines (6) from the tank. Remove nuts (1), washers (2), and bolts (3), and remove the tank from the bracket (5).
  - (3) Remove hardware and remove brackets from frame.
- b. Cleaning, Inspection, and Repair.
- (1) Clean the outside and inside surfaces of the air reservoir tank with cleaning solvent and dry with compressed air.
  - (2) Inspect for corrosion or rust.
  - (3) Inspect threaded opening and outside surfaces for cracks or damage that might result in leaks.
  - (4) Inspect the draincock for wear and defects and see that it closes properly. Inspect all other parts for defects.
  - (5) Replace a defective, unserviceable air reservoir tank or any related components.



LEGEND FOR FIGURE 19-4:

ITEM	NSN	P/N	FSCM	QTY
1. Nut, Plain	5310-00-732-0559	NS51968-8	96906	15
2. Washer, Lock	5310-00-637-9541	MS35338-46	96906	15
3. Screw, Cap	5305-00-269-2805	MS90726-62	96906	7
4. Screw, Cap		13217E0587	59678	2
5. Bracket, Air Reservoir		13217E0460	59678	4
6. Tube Assy, Air Brake		13217E0456	59678	1
7. Elbow	4730-00-069-1187	MS29182-3	96906	1
8. Adapter, Straight	4730-00-142-3076	MS39179-9	96906	1
9. Tank, Air Brake		MS500093-6	96906	1
10. Plug, Pipe	4730-00-221-2138	MS20913-35	96906	1
11. Cock, Drain	4820-00-849-1220	MS35782-5	96906	1
12. Tube Assy, Air Brake		13217E0451-8	59678	1
13. Adapter, Straight	4730-00-069-1186	MS39179-5	96906	1
14. Valve, Relay	2530-00-118-8589	MS53004-1	96906	1

Figure 19-4. Air Reservoir and Relay Valve.

c. Installation.

- (1) Install the brackets (5) in the frame and secure with hardware.
- (2) Install the air reservoir tank (9) in the brackets and secure with nuts (1), washers (2), and bolts (3).
- (3) Connect the air lines (6) to the tank and install the draincock (11).
- (4) Test the airbrake system for leaks.

**19-9. BRAKE AIR LINES AND FITTINGS.**

- a. Removal. Remove the brake lines and fittings as necessary. Pay particular attention to rubber hoses and gaskets in the four airbrake couplings at the front and rear of shop set (Refer to figures 19-5 and 19-6).
- b. Cleaning and Inspection.
  - (1) Clean parts with cleaning solvent and dry thoroughly.
  - (2) Inspect for rust, corrosion, and defects, and replace defective parts as necessary.
- c. Installation. Install the brake lines and fittings as necessary. check for leaks (Refer to figures 19-5 and 19-6).

**19-10. AIR BRAKE CHAMBER.**

- a. Removal. Remove the airbrake chamber as illustrated in figures 19-6 and 19-7.
- b. Cleaning and Inspection,
  - (1) Clean with cleaning solvent and dry thoroughly.
  - (2) Inspect for defects and replace defective or missing parts as necessary.
- c. Installation. Install the airbrake chamber as illustrated in figures 19-6 and 19-7.

**19-11. BLEEDING HYDRAULIC BRAKE SYSTEM.** Proper operation of the hydraulic portion of the brake system requires a solid column of fluid (without bubbles). It is necessary to bleed the system to expel any air which may have entered. Need for bleeding is generally indicated by soft brake action. Bleeding can be done manually or with pressure feed filler.

- a. Attach bleeder tube to bleeder screw and place other end of tube in jar or bottle, so that end is submerged in hydraulic brake fluid.

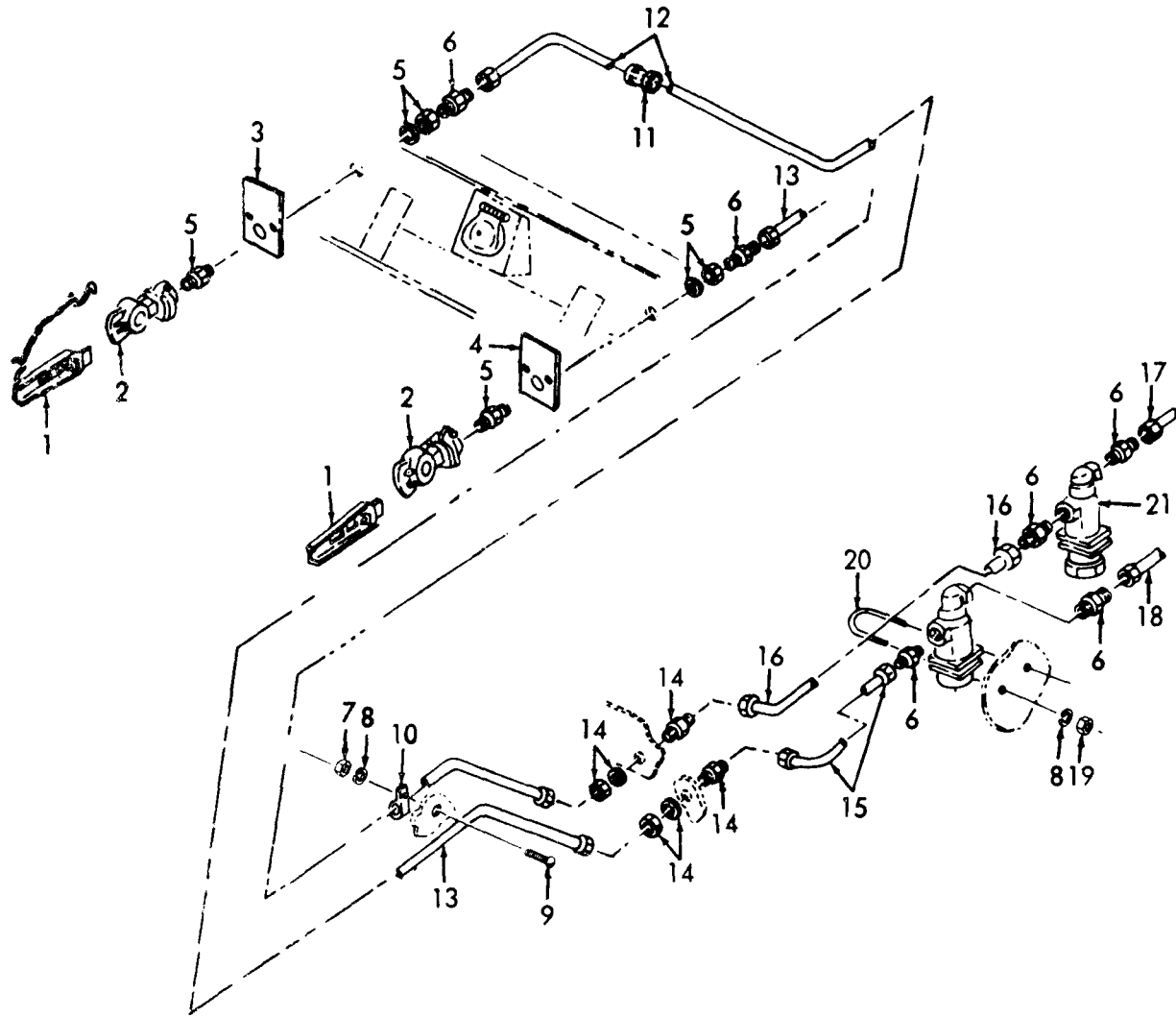


Figure 19-5. Front Air Brake Lines and Air Filter.



## LEGEND FOR FIGURE 19-5:

ITEM	NSN	P/N	FSCM	QTY
1. Coupling, Dummy		13217E0478-1	59678	4
2. Coupling Half, Quick	4730-00-595 -0083	MS35746-1	96906	4
3. Plate, ID	9905-00-999-7370	MS53007-1	96906	2
4. Plate, ID, Brake		MS53007-2	96906	2
5. Stud, Clamping		13217E0472	59678	4
6. Adapter, Straight	4730-00-069-1186	MS39179-5	96906	10
7. Nut, Plain	5310-00-768-0319	MS51968-2	96906	14
8. Washer, Lock	5310-00-582-5965	MS35338-44	96906	18
9. Screw, Machine	5305-00-993-2459	MS35207-283	96906	12
10. Clamp, Loop				
Brake Tube	5340-00-809-1492	MS21333-100	96906	22
11. Grommet Nonmetallic	5325-00-174-5318	MS35489-99	96906	2
12. Tube Assy, Air				
B rake		13217E0451-1	59678	1
13. Tube Assy, Air				
B rake		13217E0451-2	59678	1
14. Coupling, Anchor		A217709	06853	2
15. Tube Assy, Air				
B rake		13217E0451-4	59678	1
16. Tube Assy, Air				
Brake Line		13217E0451-3	59678	1
17. Tube Assy, Air				
Brake		13217E0451-5	59678	1
18. Tube Assy.		13217E0451-6	59678	1
19. Nut, Plain	5310-00-761-6882	MS51967-2	96906	8
20. Bolt, U	5306-01-066-3528	13217E0458	59678	2
21. Air Filter, Air				
Brake	2530-00-797-9295	225357	06853	2

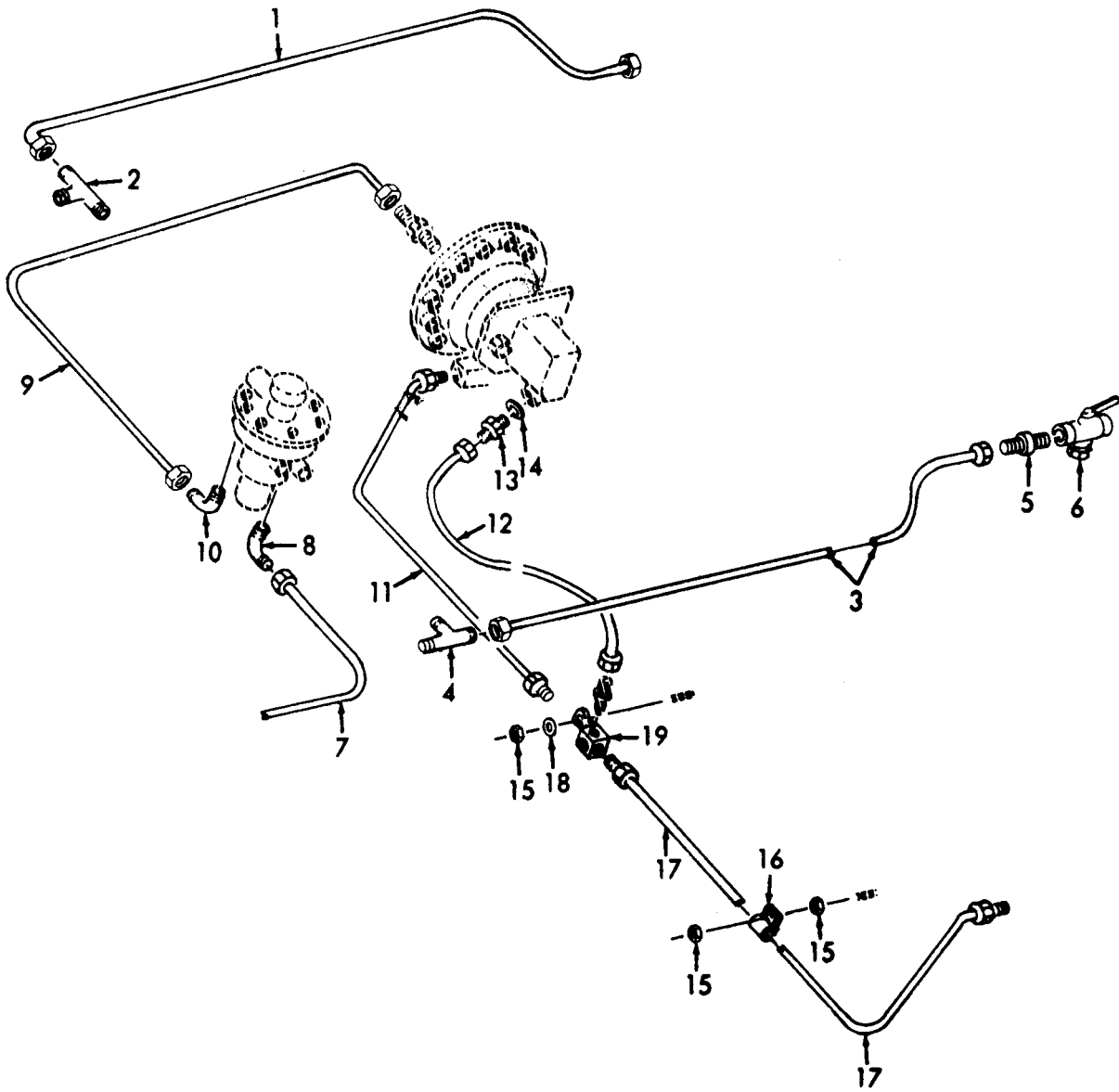


Figure 19-6. Rear Air Brake Lines.

## LEGEND FOR FIGURE 19-6:

ITEM	NSN	P/N	FSCM	QTY
1. Tube Assy, Air Brake		13217 E0451-9	59678	1
1. Tube Assy, Air Brake Line		13217 E0451-9	59678	1
2. Tee Brake		MS39191-2	96906	1
3. Tube Assy, Air Brake		13217 E0451-10	59678	1
4. Tee, Tube Brake		MS39188-2	96906	1
5. Adapter, Straight	4730-00-837-1177	MS39179-7	96906	2
6. Cock , Cut-Out		13217 E0477	59678	2
7. Tube Assy.		13217 E0451-11	59678	1
8. Elbow, Pipe to Tube	4730-00-069-1187	MS39182-3	96906	1
9. Tube Assy, Air Brake		13217 E0451-7	59678	1
10. Elbow, Pipe to Tube	4730-00-269-2841	MS39185-3	96906	1
11. Tube Assy, LH Hydraulic		13217 E0455	59678	2
12. Hose Assy, Brake Master Cyl.		13217E0467	59678	2
13. Connector Brake		13217E0468	59678	2
14. Gasket Brake		13217E0469	59678	2
15. Nut, Self-Locking	5310-00-088-1251	MS51922-1	96906	6
16. Clamp, Loop	5340-00-809-1490	MS21333-98	96906	4
17. Tube Assy, RH Hydraulic		13217E0452	59678	2
18. Washer, Step Brake		13217E0596	59678	2
19. Tee, Flared Tube		13217E0470	59678	2

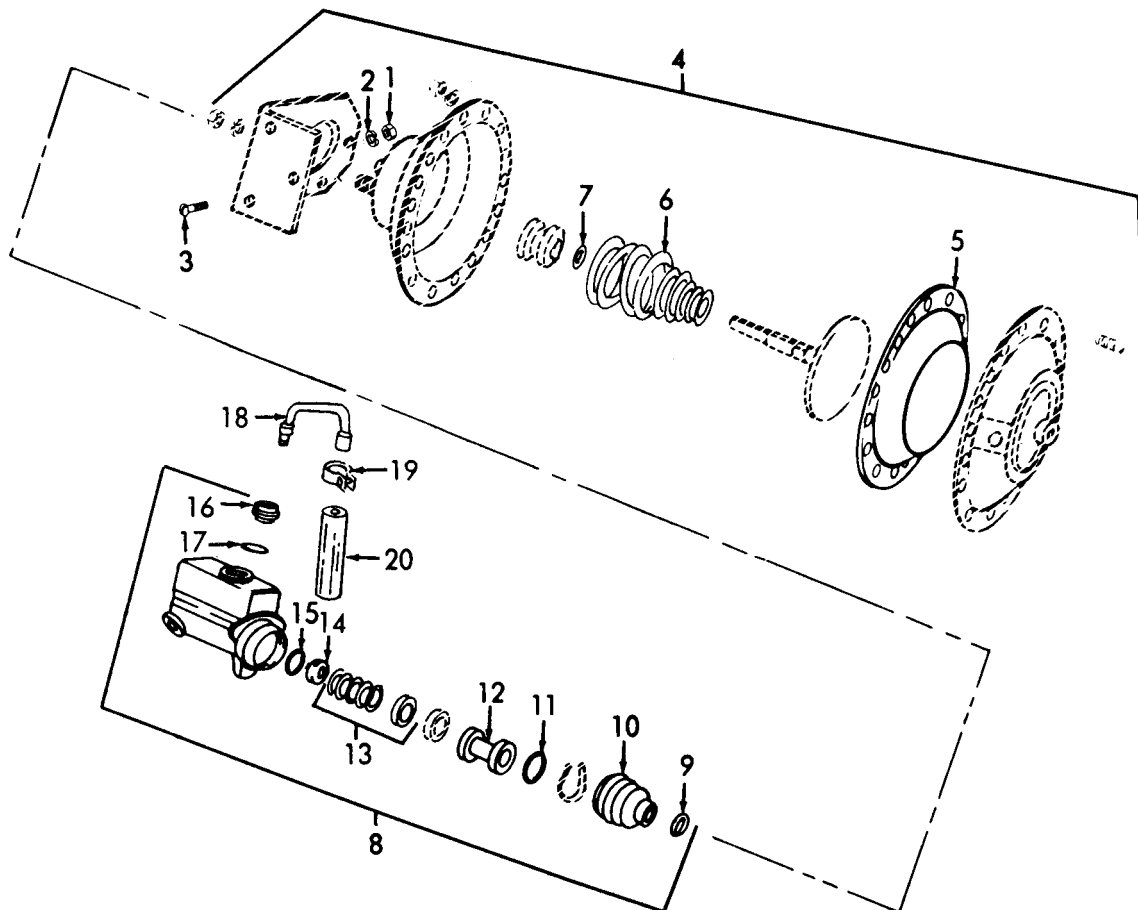


Figure 19-7. Brake Air Chamber and Master Cylinder.

## LEGEND FOR FIGURE 19-7:

ITEM	NSN	P/N	FSCM	QTY
1. Nut, Plain	5310-00-732-0559	MS51968-8	96906	3
2. Washer, Lock	5310-00-637-9541	MS35338-46	96906	3
3. Screw	5305-00-269-2803	MS90726-60	96906	6
4. Chamber Assy. Brake		13217E0462	59678	2
5. Diaphragm, Chamber	2530-00-424-0901	210816	06853	1
6. Spring, Return		7306-01	06853	1
7. Packing, Preformed	5330-00-618-0801	MS28775-114	96906	1
8. Cylinder Assy, Master	2530-00-278-2243	8332086	19207	2
9. Strap, Boot		5167880	19207	1
10. Bellows	2530-00-753-9308	FC12335	63477	1
11. Cup, Master		FD1367	63477	1
12. Piston Assy, Master		FC1338	63477	1
13. Spring & Valve Assy, Master		FC14330	63477	1
14. Seat, Valve, Master		FC14213	63477	1
15. Cup, Master		FD962	63477	1
16. Filler Cap Assy	5365-00-773-2163	FC14324	63477	1
17. Spacer, Ring, Master Cyl., Filer Cap	5365-00-737-3354	FC3587	63477	1
18. Tube Assy, Brake		13217E0465	97403	2
19. Clamp, Hose Brake	4730-00-908-3194	MS35842-11	96906	2
20. Hose, Preformed Brake	4720-00-809-2750	8365425	19207	2

- b. Remove filler plug from top of master cylinder. Fill cylinder with brake fluid. Replace filler plug.
- c. While brake pedal on towing vehicle is being pumped slowly up and down, open bleeder screw by turning three-quarters of a turn counterclockwise. Liquid will be forced through the line to expel air which will show as bubbles in fluid coming out of tube.
- d. Repeat operation approximately ten times or until air bubbles do not appear. Watch flow, keeping tube submerged in fluid. When air bubbles cease and stream is clear, close bleeder valve firmly. Remove bleeder.
- e. Repeat operations in steps (1) thru (4) on each of the other wheels.
- f. When all four wheel cylinders have been bled, fill master cylinder with brake fluid and replace filler plug.

### NOTE

When bleeding brakes, keep master cylinder as full as practical to prevent pumping air into the fluid lines.

### 19-12. BRAKE SHOES.

- a. Removal.
  - (1) Remove the hub and brake drum (para. 19-15).
  - (2) Remove the two C-washers (23, figure 19-8) and remove strap (8).
  - (3) Remove the brake release springs (14) and remove the brake shoes (11).
- b. Cleaning, Inspection, and Repair.
  - (1) Use an approved cleaning solvent to clean all metal parts and brake linings.
  - (2) Inspect the brake linings for excessive wear. If linings are worn within one-sixteenth to one-thirty-second inch from the head of the brake lining rivets, the brake shoes should be replaced.
  - (3) Inspect brake linings for traces of oil or grease. If oil or grease saturation is evident, replace the brake shoes.
  - (4) Replace all defective brake components.
- c. Installation.
  - (1) Install in reverse order of a above.

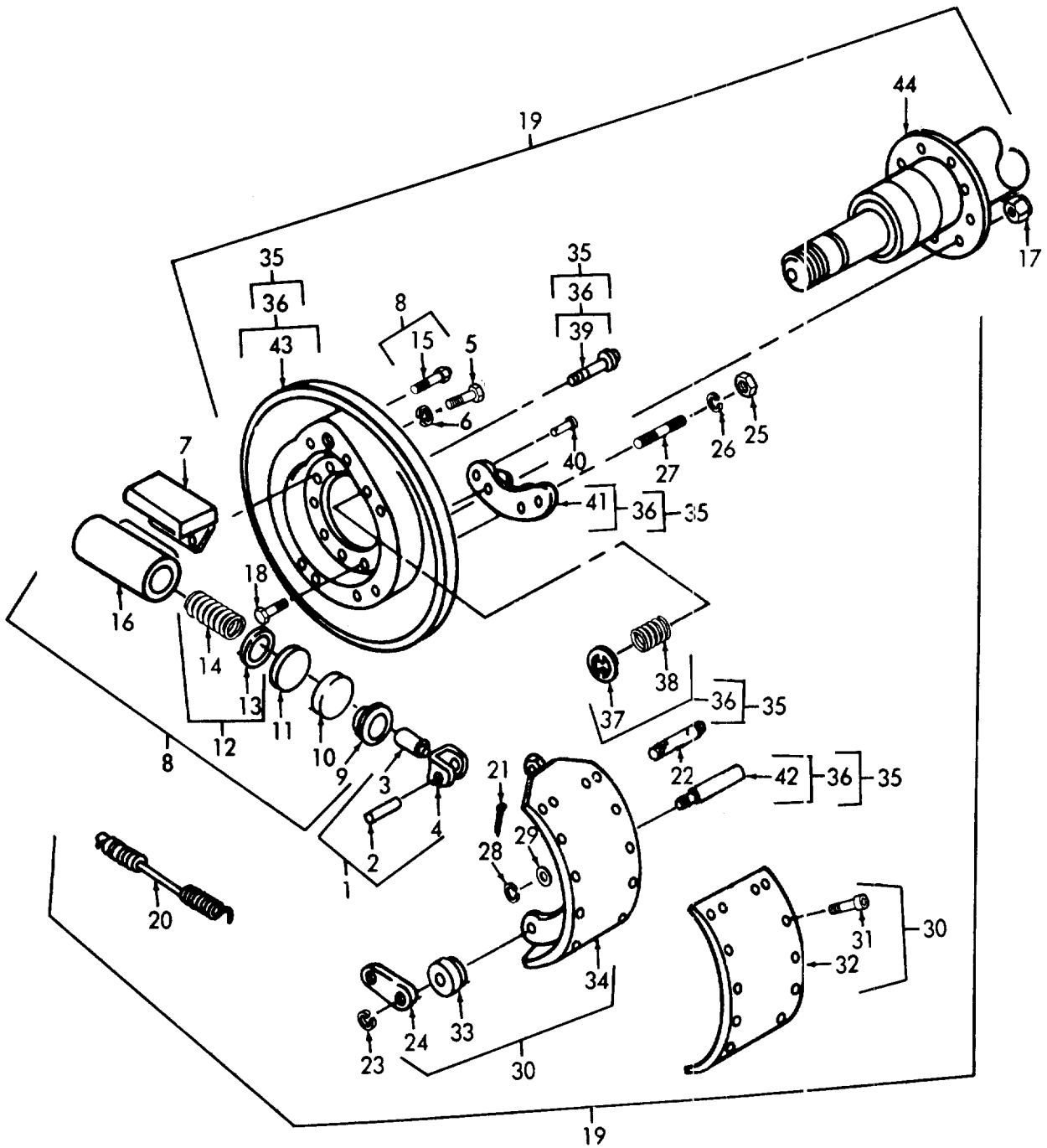


Figure 19-8. Brake Shield and Shoe.

LEGEND FOR FIGURE 19-8:

ITEM	NSN	P/N	FSCM	QTY
1. Yoke & Pin Assy.		7413486	19207	4
2. Pin, Yoke		8758267	19207	1
3. Pin, Connecting Link		7409326	19207	1
4. Yoke, Connector		8758271	19207	1
5. Screw, Cap	5305-01-010-2362	MS90725-59	96906	4
6. Washer	5310-00-543-5101	MS35338-27	96906	4
7. Cover, Wheel Cyl.		7409323	19207	2
8. Cylinder Assy.	2530-00-920-7568	8758259	19207	2
9. Boot	2530-00-845-8502	8758264	19207	2
10. Piston	2530-00-287-2566	8333649	19207	2
11. Cup	2530-00-696-0647	8758263	19207	2
12. Spring Helical, Comp	5360-00-321-6413	8333750	19207	1
13. Retainer, Spring		8758262	19207	1
14. Spring		8758367	19207	1
15. Screw, Bleeder		7411071	19207	1
16. Cylinder		8758254	19207	1
17. Nut, Self-Locking	5310-00-897-5940	MS51922-45	96906	20
18. Screw, Cap	5305-00-724-6772	MS90726-139	96906	20
19. Shield & Shoe Assy.		8376667	19207	2
20. Spring, Helical	5360-00-797-9339	7979339	19207	1
21. Pin, Cotter		10938315-1	19207	4
22. Pin, Spring		7979330	19207	2
23. Washer, Retaining		7979332	19207	2
24. Strap, Shoe to Shoe		7979340	19207	1
25. Nut, Plain	5310-00-275-9460	7207919	19207	2
26. Washer	5310-00-584-7888	MS35338-51	96906	2
27. Pin, Shoe Ret.		7979271	19207	2
28. Washer, Ret. Shoe		5331913	19207	2
29. Washer, Flat Shoe		594261	19207	4
30. Shoe	2530-00-864-2990	7409380	19207	2
31. Rivet, Tubular Lining	5320-00-058-9883	MS16536-172	96906	16 lb.
32. Lining, Brake		8758256	19207	1
33. Bushing		7979280	19207	2
34. Shoe, Brake		8758318	19207	1
35. Plate Assy.		7409381	19207	1
36. Plate, Mtg.		8332557	19207	1
37. Cam		5282725	19207	2
38. Spring, Helical	5360-00-740-9382	7409382	19207	2
39. Pin Shoulder, Headed	5315-00-740-9376	7409376	19207	2
40. Rivet		10947116	19207	4
41. Bracket		7979334	19207	1
42. Pin		7409378	19207	2
43. Cover		8758316	19207	1
44. Axle		10950323	19207	1



- (2) Adjust the brakes.

### 19-13. BRAKE LINING REPLACEMENT.

- a. Removal and Disassembly (Refer to figure 19-8).
  - (1) Remove the hub and drum (para. 19-15).
  - (2) Remove the brake shoes (para. 19-12).
  - (3) Remove the rivets and remove the brake linings (9) from the brake shoes.
- b. Assembly and Installation.
  - (1) Install brake lining on brake shoes and secure with rivets.
  - (2) Install the brake shoes.

### 19-14. SPRINGS.

- a. Removal.
  - (1) Remove the wheels (para. 19-4).
  - (2) Remove the four nuts (2, figure 19-9) and two U-bolts (13) that secure the springs saddle (15), and remove the spring saddle.
  - (3) Loosen two clamping screws and remove springs.
- b. Cleaning, Inspection, and Repair.
  - (1) Clean parts with approved cleaning solvent and dry thoroughly.
  - (2) Inspect springs for cracks, breaks, and other defects. Replace damaged springs.
  - (3) If spring seat is damaged, remove with a cutting torch and weld a new spring seat to the axle tube.
- c. Installation. Install in reverse order of a. above.

### 19-15. FRAME SUSPENSION AND AXLE ASSEMBLY.

- a. Removal.
  - (1) Raise the frame with a suitable lifting device and block securely. Wheels should be free of the ground.
  - (2) Disconnect the brake lines from the axle assembly.
  - (3) Remove the forty-four bolts (1 through 5, figure 19-9), washers and nuts that secure the frame suspension to the frame and remove the frame suspension, axle, and wheels as a unit.

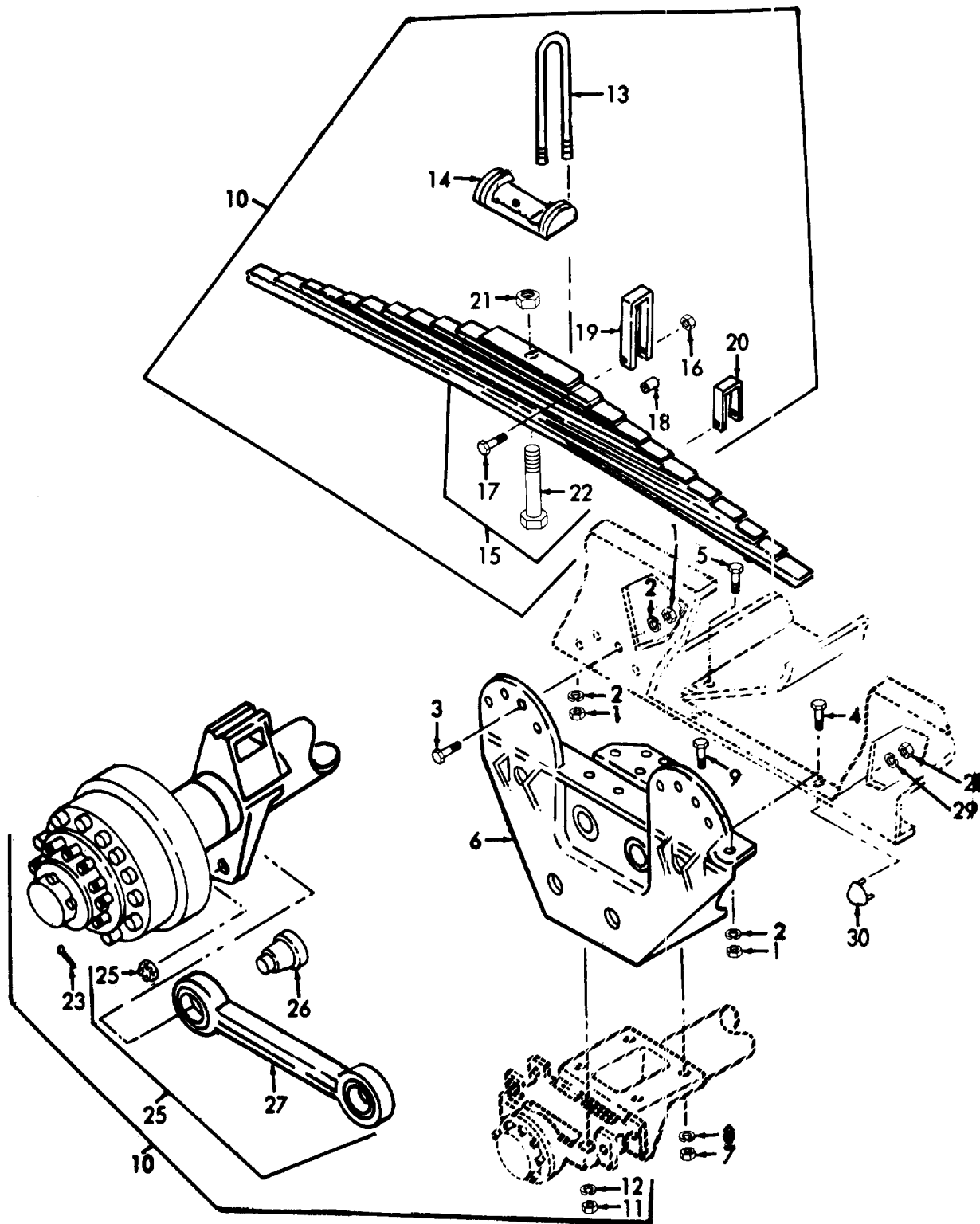


Figure 19-9. Axle Assembly.

## LEGEND FOR FIGURE 19-9:

ITEM	NSN	P/N	FSCM	QTY
1. Nut, Plain	5310-00-763-8905	MS51968-20	96906	44
2. Washer	5310-00-820-6653	MS35338-50	96906	44
3. Screw, Cap	5305-00-726-2551	MS90726-164	96906	28
4. Screw, Cap	5305-00-726-2552	MS90726-165	96906	4
5. Screw, Cap	5305-00-726-2250	MS90726-163	96906	12
6. Bracket		13217E0521	59678	2
7. Nut, Plain	5310-00-762-6213	MS51968-32	96906	8
8. Washer	5310-00-850-1611	MS35338-54	96906	8
9. Bolt, Machine		13217E0527	59678	8
10. Axle Assembly		13217E0602	59678	1
11. Nut, Plain	5310-00-798-1265	7979366	19207	8
12. Washer	5310-00-584-7889	MS35338-53	96906	8
13. U-Bolt	5306-00-797-9365	7979365	19207	4
14. Saddle, Axle		7979316	19207	1
15. Spring		7979217	19207	1
16. Nut, Plain	5310-00-891-1711	MS35691-25	96906	4
17. Bolt		7979424	19207	4
18. Spacer, Spring Clip		7979423	19207	4
19. Clip		7979421	19207	2
20. Clip		7979422	19207	2
21. Nut, Plain	5310-00-010-3028	MS35690-824	96906	1
22. Bolt	5306-00-206-7279	7979425	19207	1
23. Pin	5315-00-187-9567	MS24665-500	96906	12
24. Torque Rod Assy.		7979189	19207	6
25. Nut, Castellated		7979183	19207	2
26. Ball Assy.		7979185	19207	2
27. Rod Assy.		7979188	19207	1
28. Nut, Plain	5310-00-880-7744	MS51967-5	96906	8
29. Washer, Lock	5310-00-407-9566	MS35338-45	96906	8
30. Bumper, Axle		13217E0526	59678	4
31. Axle Assy .		10950340	19207	1

b. Cleaning, Inspection, and Repair.

- (1) Remove grease and dirt with approved cleaning solvent and dry thoroughly.
- (2) Inspect for damage and defects and replace any defective parts as necessary.

c. Installation (Refer to figure 19-9).

- (1) Secure the frame suspension, axle, and wheels unit to the frame with the forty-four bolts, washers, and nuts (1 through 5).
- (2) Connect the brake lines to the axle.
- (3) Remove blocking and lower the wheels to the ground.

**19-16. TORQUE RODS.**

a. Removal.

- (1) Raise the shop set with a suitable lifting device until the wheels are off the ground.
- (2) Remove the two cotter pins and two nuts (24 and 26, figure 19-9) that secure the torque rod (25) to the frame support bracket.
- (3) Remove the other five torque rods in a similar manner.

b. Cleaning, Inspection, and Repair.

- (1) Clean all metal parts with an approved cleaning solvent and dry thoroughly. Wipe the rubber bushings with a clean, dry cloth.
- (2) Inspect all metal parts for breaks, bends, cracks, damaged threads, or other damage. Replace all damaged parts. Inspect the rubber bushings for breaks, tears, or deterioration, and replace if necessary.

c. Installation. Install in reverse order of a. above.

**19-17. PIVOT AXLE.**

a. Disassembly. Disassemble the pivot axle as shown in figure 19-10,

b. Cleaning, Inspection, and Repair.

- (1) Clean parts with approved cleaning solvent and dry thoroughly.
- (2) Check bearings, seats, and oil seals for damage.
- (3) Check axle spindle for straightness, cross threads, or damage.
- (4) Replace all worn or damaged parts,

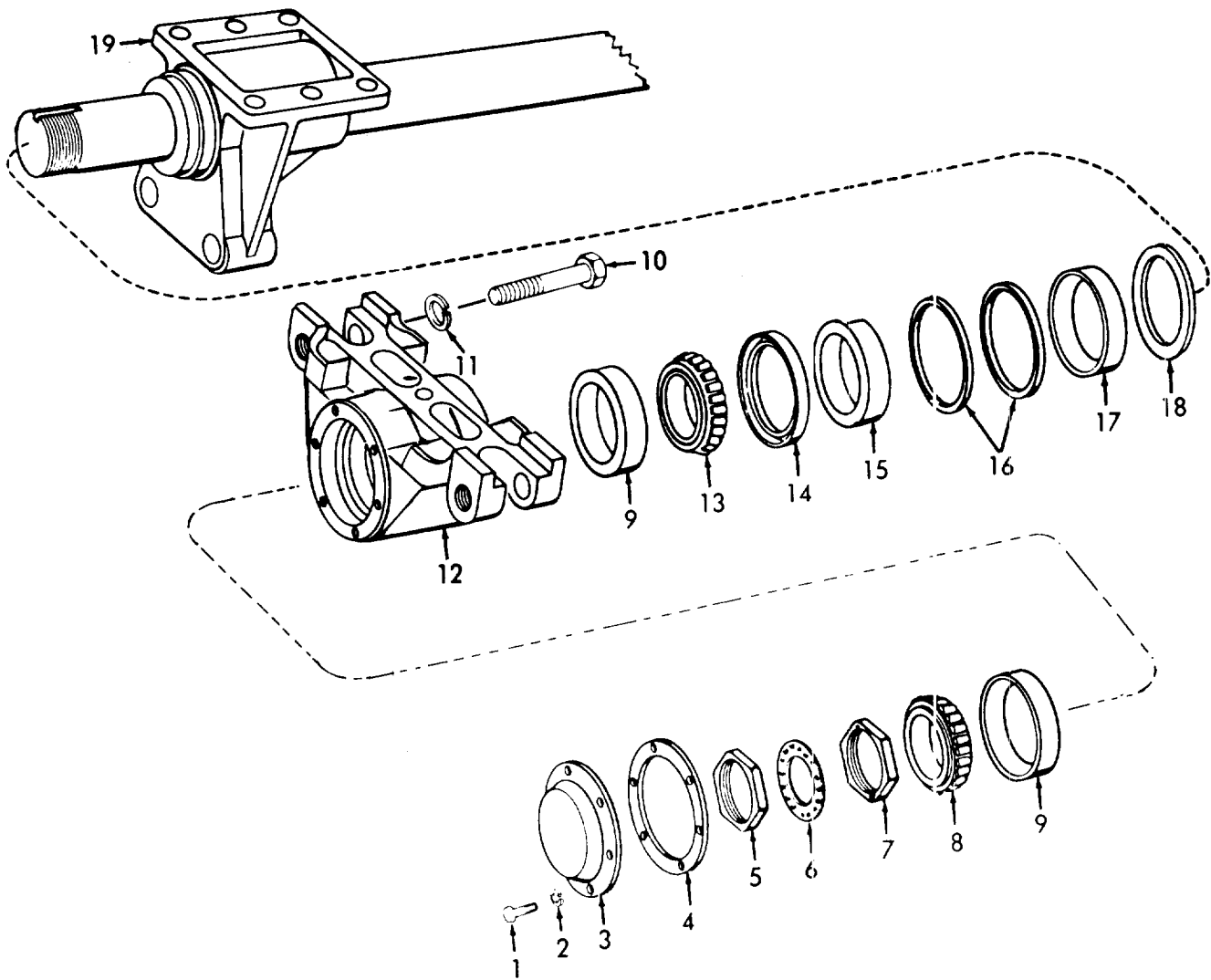


Figure 19-10. Pivot Axle.

LEGEND FOR FIGURE 19-10:

ITEM	NSN	P/N	FSCM	QTY
1. Bolt, Machine	5306-00-225-8494	MS90725-29	96906	12
2. Washer, Lock	5310-00-407-9566	MS35338-45	96906	12
3. Cap, Bearing Cover		7979306	19207	2
4. Gasket, Bogie	5330-00-740-9600	7979274	19207	2
5. Nut, Bearing		7979263	19207	2
6. Washer, Bearing		5139123	19207	2
7. Nut, Bearing		7979308	19207	2
8. Cone & Roller		705155	19207	2
9. Cup, Bearing		706691	19207	2
10. Bolt, Machine	5306-00-740-9608	7979329	19207	4
11. Washer, Lock	5310-00-616-3056	MS35335-41	96906	4
12. Seat Assembly		7979312	19207	2
13. Cone & Roller	3110-00-689-8250	712286	19207	2
14. Seal Plain Encased	5330-00-740-9550	7979349	19207	2
15. Felt, Mechanical		7979264	19207	2
16. Seal, Oil Bogie	5365-00-740-9312	7979267	19207	2
17. Ring	2530-00-740-9553	7979266	19207	2
18. Washer, Bogie		7979265	19207	2
19. Tube Assy.		7409607	19207	1

c. Assembly.

- (1) Install in reverse order of a. above.
- (2) Use wrench (NSN 5120-00-795-0059) to tighten adjusting nut (7, figure 19-10) sufficiently to force roller bearing cones (8 and 13) into place and then back off nut until seat (12) can be turned freely by hand, but without lateral movement of seat due to oil and lubricant in bearing cones.
- (3) Install washer (6) so that the pin on the adjusting nut (7) protrudes through the washer (6) to hold the adjusting nut (7) in place. The adjusting nut (7) may have to be turned to align the pin on the adjusting nut (7) with the nearest hole on the washer.
- (4) Add 16-ounce GAA grease (GAA 9150-00-190-0904) into spring seat assembly.

**19-18. LANDING GEAR.**a. Removal.

- (1) Raise and block up front of trailer chassis. Chock wheels to prevent movement of vehicle.
- (2) Remove the two screws that secure the two braces to the leg assembly (fig. 19-11).
- (3) Remove the eight screws that secure the leg assembly to the trailer chassis. Remove the leg assembly.
- (4) Remove the remaining leg assembly in a similar manner.

b. Disassembly. Disassemble the landing gear leg assembly as illustrated in figure 19-12.c. Cleaning, Inspection, and Repair.

- (1) Clean all parts with approved cleaning solvent and dry thoroughly .
- (2) Inspect all parts for wear, distortion or cracks. With fine file, hand-chase at ends of screws on leg assemblies. Check gears and retaining nuts for damage and replace if necessary. Check screw and nut on leg assemblies for damage, wear, or corrosion. Inspect roller bearings for wear and replace if unserviceable. Inspect bearings for signs of damage and wear. Replace if defective. Inspect gear shaft for burrs, damage and wear. Replace if necessary. Check to be sure that contact surface of gib is smooth. Clean and inspect all exterior surfaces for chipped paint. Repaint as necessary after scraping chipped paint. Check lube fittings for serviceability y. Replace all parts as necessary.

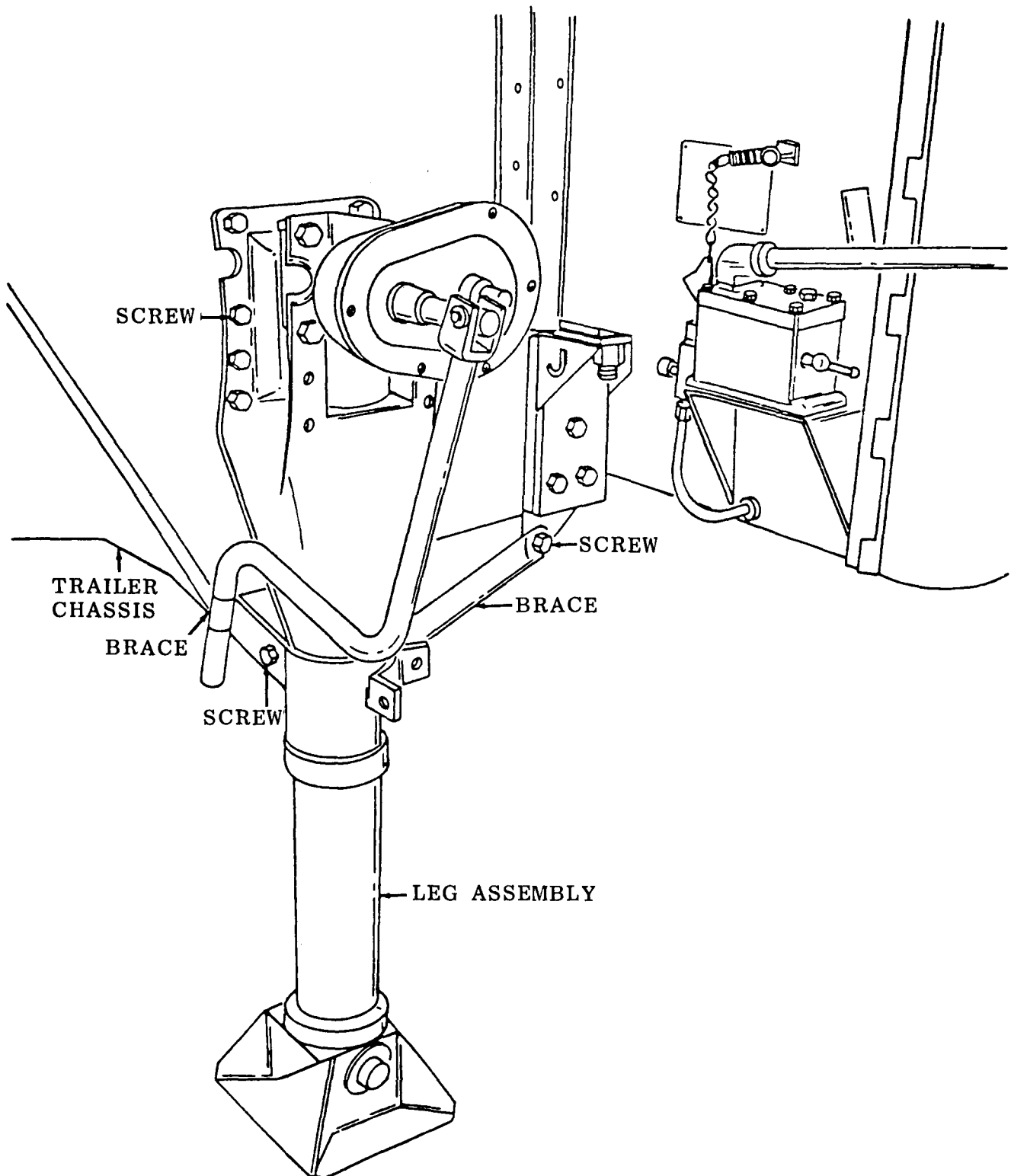


Figure 19-11. Landing Gear, Removal and Installation.



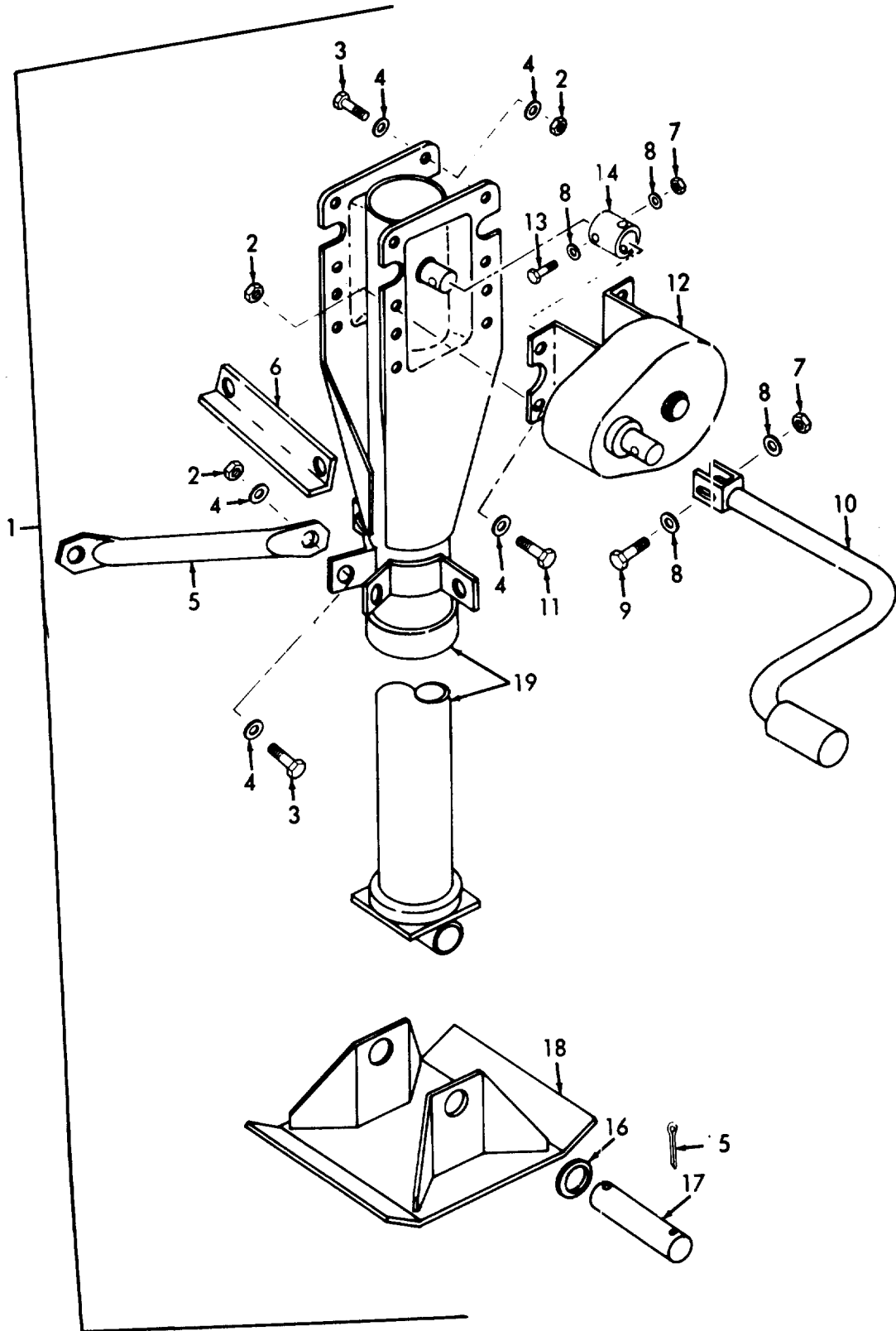


Figure 19-12. Landing Gear.

LEGEND FOR FIGURE 19-12:

ITEM	NSN	P/N	FSCM	QTY
1. Landing Gear		11021086	59678	1
2. Nut, Self-Locking	5310-00-269-4040	MS51922-49	96906	8
3. Screw, Cap	5305-00-051-0827	MS90725-164	96906	24
4. Washer, Flat	5310-00-823-8803	MS27183-21	96906	16
5. Brace, Support Assy.		11625075	19207	2
6. Brace,		11021087	59678	2
7. Nut, Self-Locking	5310-00-087-4652	MS51922-17	96906	6
8. Washer, Flat	5310-00-809-4061	MS27183-15	96906	8
9. Screw, Cap	5305-00-269-3217	MS90725-67	96906	4
10. Crank Assy, Support		11640134	19207	2
11. Screw, Cap	5305-00-724-5910	MS90725-162	96906	8
12. Gear Box, Support Assy.		11625431	19207	2
13. Screw, Cap	5305-00-269-3217	MS90725-67	96906	4
14. Coupling, Gear Box		11625128	19207	2
15. Pin, Spring		MS9048-304	96906	4
16. Washer, Support Axle		11625086	19207	2
17. Axle, Support Assy.		11625085	19207	2
18. Shoe, Support Assy.		11681636	19207	2
19. Leg Assy, Support		11625119	19207	2

- d. Assembly. Reassemble the landing gear leg assembly as illustrated in figure 19-12.
- e. Installation.
  - (1) Position the landing gear leg assembly to the trailer chassis and secure with eight screws (fig. 19-11).
  - (2) Position the two braces between the chassis and the leg assembly and secure with a screw, washer, and nut at each end of both braces.

### 19-19. ENGINE ENCLOSURE.

- a. Removal (Refer to figures 19-13, 19-14, and 19-15).
  - (1) Disconnect the shutter control cable from the shutter assembly by removing the snap ring that retains the cable clamping device to the shutter. Then, remove the four clamps that retain the cable to the left side of the engine enclosure.
  - (2) Remove the ladder from its stowed position on the right side of the engine enclosure.
  - (3) Remove the muffler (para. 11-2).
  - (4) Remove the fuel tank assembly (para. 8-2).
  - (5) Disconnect the front clearance lights at the trailer wiring harness.
  - (6) Remove the four nuts, washers, and screws, that secure the engine enclosure to the trailer frame and brackets.
  - (7) Attach a suitable lifting device and move the engine enclosure forward until the rear of the enclosure is free to move upward.
- b. Cleaning, Inspection, and Repair.
  - (1) Clean metal parts with cleaning solvent and dry thoroughly.
  - (2) Clean rubber parts with a cloth dampened in clean water.
  - (3) Inspect moving parts for binding and improper operation.
  - (4) Inspect metal parts for cracks, dents, excessive wear and other damage. Inspect rubber parts for deterioration.
  - (5) Replace defective doors, gaskets, hinges, braces, panels, latches, and handles, as required.
- c. Installation. Install the engine enclosure in the reverse order of removal.

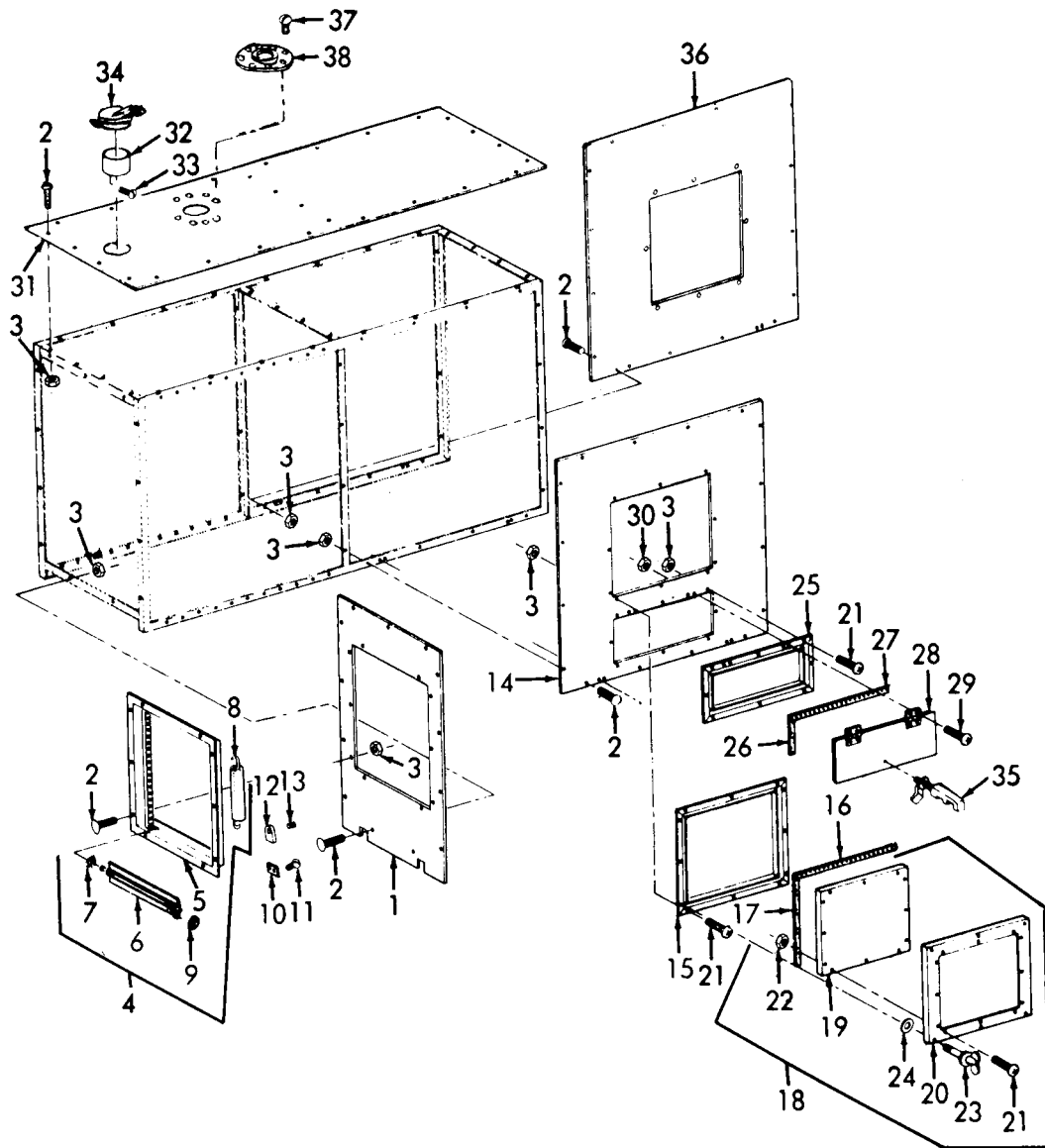


Figure 19-13. Compartment Panels and Access Doors.

## LEGEND FOR FIGURE 19-13:

ITEM	NSN	P/N	FSCM	QTY
1. Panel, Front		13221 E9021	59678	1
2. Bolt, Step Carriage		MS35751-2	96906	83
3. Nut, Self Locking	5310-00-689-3877	MS17829-3C	96906	101
4. Shutter Assy.		1045-03063-02	51377	1
5. Box Assy, Shutter		830080	51377	1
6. Vane and Seal		821017	51377	12
7. Bearing Shutter Vane		A1884	75418	24
8. Spring Shutter		212X	75418	1
9. Seal, Vane Shutter		816302	75418	12
10. Bracket, Casing		4013-03415-01	51377	1
11. Screw, Machine		3044-00661-16	51377	2
12. Cable, End		4016-03383-01	51377	1
13. Setscrew		3045-00714-05	51377	2
14. Panel, Engine Housing		13221 E9023	59678	1
15. Frame		13217 E0507	59678	2
16. Strip	5330-01-096-8595	13217 E0471	59678	4
17. St rip	5330-01-089-7794	13217 E0530	59678	4
18. Door Assy.		13217 E0502	59678	2
19. Panel, Inspection Door Assy.		13217 E0503	59678	1
20. Frame, Door Assy.		13217 E0504	59678	1
21. Screw	5305-00-984-6213	MS35206-266	96906	12
22. Nut	5310-01-068-5523	MS17829-36C	96906	12
23. Fastener	5305-00-776-9555	13217E0505-32	59678	8
24. Washer, Retaining	5310-00-880-9344	12-11014-12	94222	8
25. Frame		13217E0508	59678	1
26. Strip		13217E0528-2	59678	2
27. Strip		13217E0528-1	59678	2
28. Door, Access		13217E0509	59678	1
29. Screw, Machine	5305-00-245-9662	MS35190-256	96906	4
30. Nut, Self-Locking	5310-00-811-3494	MS21044NO8	96906	4
31. Panel, Top		13221E9022	59678	1
32. Collar, Engine Housing		13217E0566	59678	1
33. Screw, Tapping	5305-00-432-4201	MS51861-45	96906	4
34. Cap, Assembly	2990-00-793-7780	20	95817	1
35. Latch		13217E0519	59678	1
36. Panel, Engine Housing		13221E9024	59678	1
37. Screw	5305-00-988-1727	MS35206-283	96906	8
38. Collar		13217E0565	59678	1

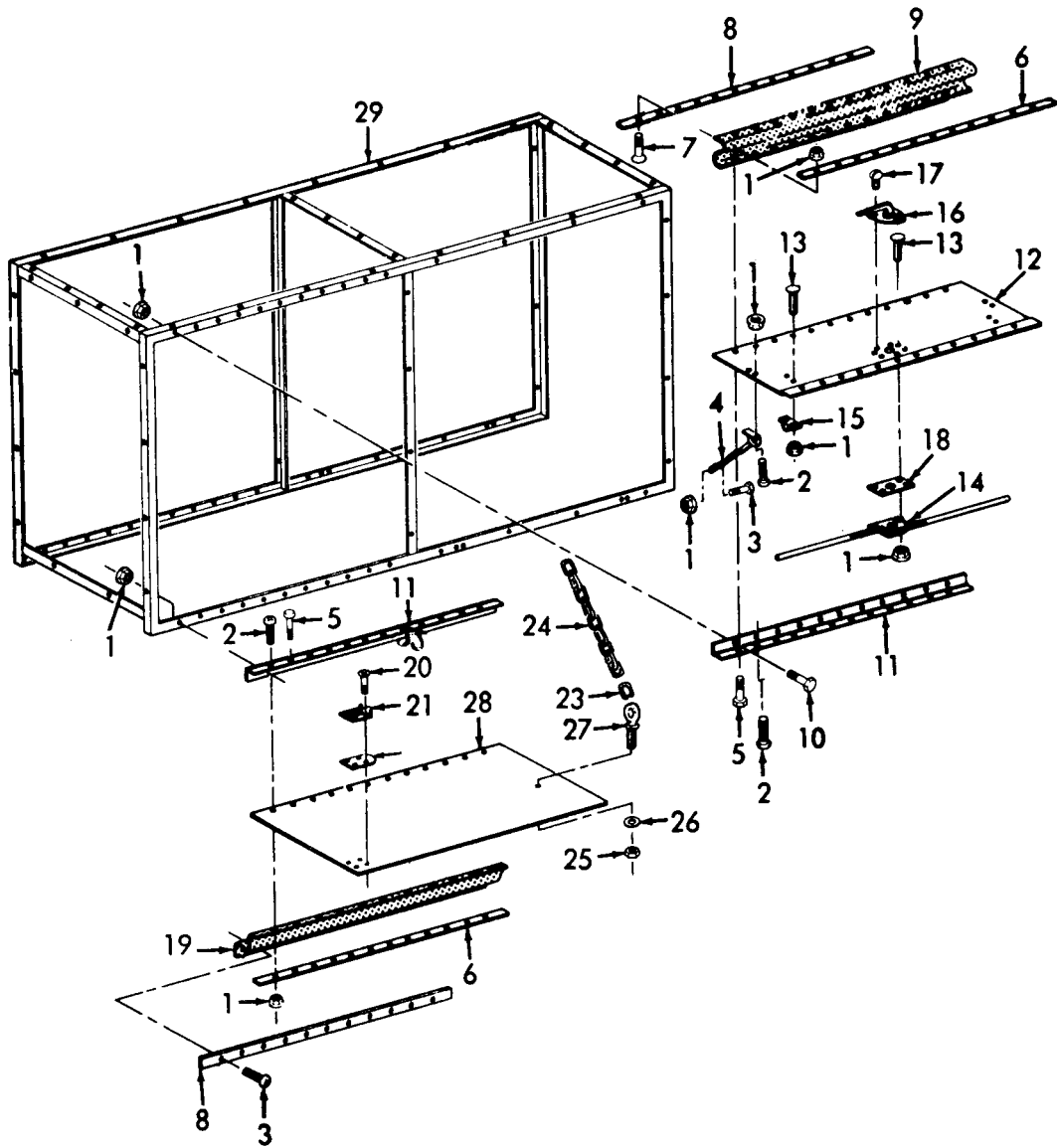
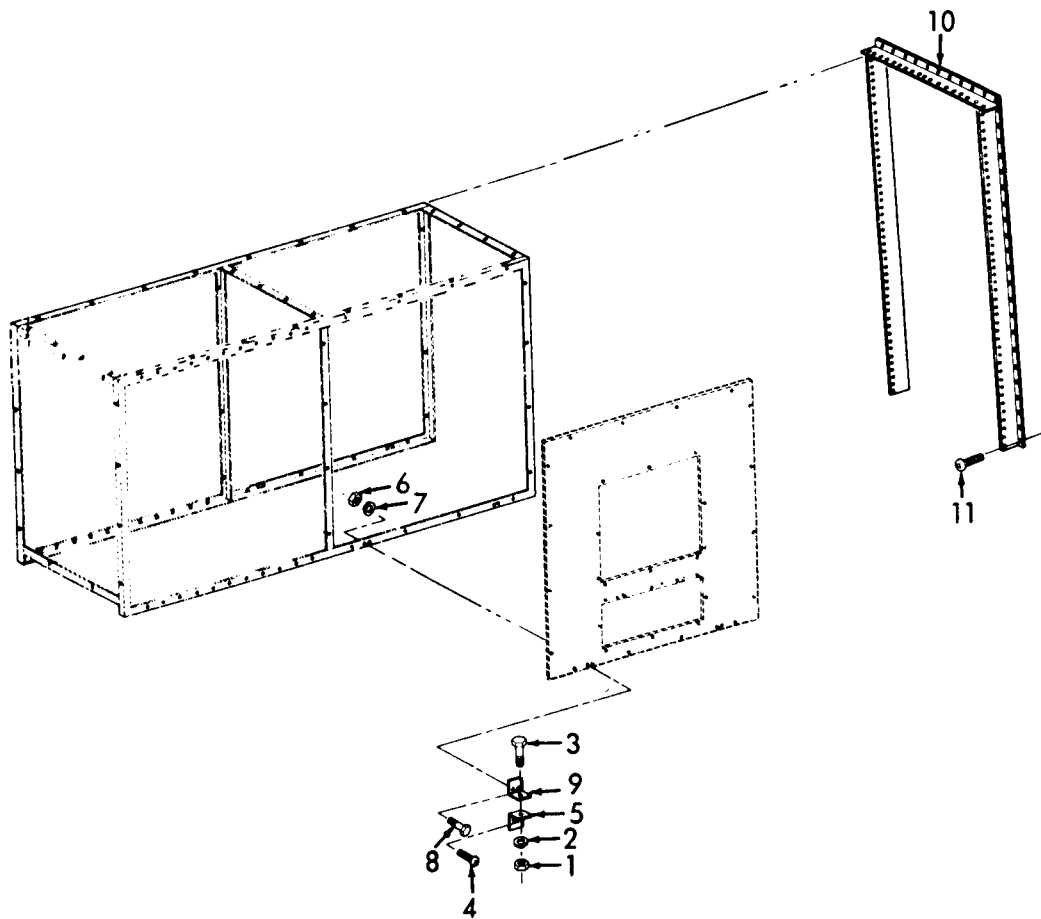


Figure 19-14. Compartment Doors.

## LEGEND FOR FIGURE 19-14:

ITEM	NSN	P/N	FSCM	QTY
1. Nut, Self-Locking	5310-00-689-3877	MS17829-3C	96906	146
2. Screw, Machine	5305-00-957-6269	MS35190-275	96906	16
3. Screw, Machine	5305-01-006-2053	MS51849-75	96906	28
4. Stay, Locking	4940-01-066-8776	13217E0603-2	59678	2
5. Screw	5305-00-240-6668	MS51849-78	96906	40
6. Retainer, Engine Housing		13217E0493	59678	4
7. Screw, Tapping	5305-00-138-0069	MS51861-44	96906	24
8. Seal, Rubber, Strip				
	5330-01-070-2127	13217E0494	59678	2
9. Seal, Engine Housing		13217E0501-1	59678	2
10. Screw	5305-00-470-3321	MS51849-74	96906	24
11. Hinge, Engine Housing		13217E0495	59678	4
12. Door, Engine Housing		13217E0497	59678	2
13. Bolt		MS35751-3	96906	12
14. Lock, Door Engine Housing		13217E0496	59678	2
15. Guide, Rod		5611-6X	19220	2
16. Handle, Door		SW2553P2	98255	2
17. Bolt		MS35751-3	96906	4
18. Plate, Lock		13217E0499	59678	2
19. Seal, Door		13217E0501-2	59678	2
20. Screw, Thread Tapping		ANS-818-6-4	80204	8
21. Bolt, Barrel	5340-00-498-6120	13217E1129	59678	2
22. Spacer, Barrel Bolt		13217E1126	59678	2
23. Chain, Weldless	4010-00-585-2108	043974	16003	4
24. Chain		13218E0028-2	97403	4
25. Nut	5310-00-087-4652	MS51922-17	96906	4
26. Washer, Flat	5310-00-080-6004	MS27183-14	96906	8
27. Connecting Rod End		13217E1173	59678	4
28. Door, Engine		13217E0489	59678	2
29. Frame, Engine		13217E0482	59678	1



LEGEND FOR FIGURE 19-15:

ITEM	NSN	P/N	FSCM	QTY
1. Nut	5310-00-732-0558	MS51967-8	96906	8
2. Washer	5310-00-637-9541	MS35338-46	96906	8
3. Screw, Cap	5305-00-942-2196	MS90725-60	96906	4
4. Screw, Tapping	5303-00-052-6923	MS24629-59	96906	8
5. Bracket		13217E0589	59678	4
6. Nut, Plain	5310-00-761-6882	MS51967-2	96906	8
7. Washer, Lock	5310-00-582-5965	MS35338-44	96906	8
8. Screw	5305-00-071-2241	MS90725-10	96906	8
9. Bracket, Panel		13217E0573	59678	4
10. Seal Assy.		13217E0567	59678	1
11. Screw	5305-00-052-6921	MS24629-57	96906	31

Figure 19-15. Compartment Panel Brackets and Seal Assembly.



**19-20. FRAME BRACKETS.**

- a. Removal. Refer to figure 19-16 to remove the front brackets.
- b. Installation. Install the front brackets as shown in figure 19-16.

**19-21. TOWING PINTLE.**

- a. Removal. Remove the towing pintle as shown in figure 19-17.
- b. Disassembly. Disassemble the towing pintle as shown in figure 19-17.
- c. Assembly. Assemble the towing pintle as shown in figure 19-17.
- d. Installation. Install the towing pintle as shown in figure 19-17.

**19-22. FRONT LADDER.**

The front ladder can be repaired as shown in figure 19-18.

**19-23. FRAME WIRING.**

The frame wiring can be repaired as shown in figure 19-19.

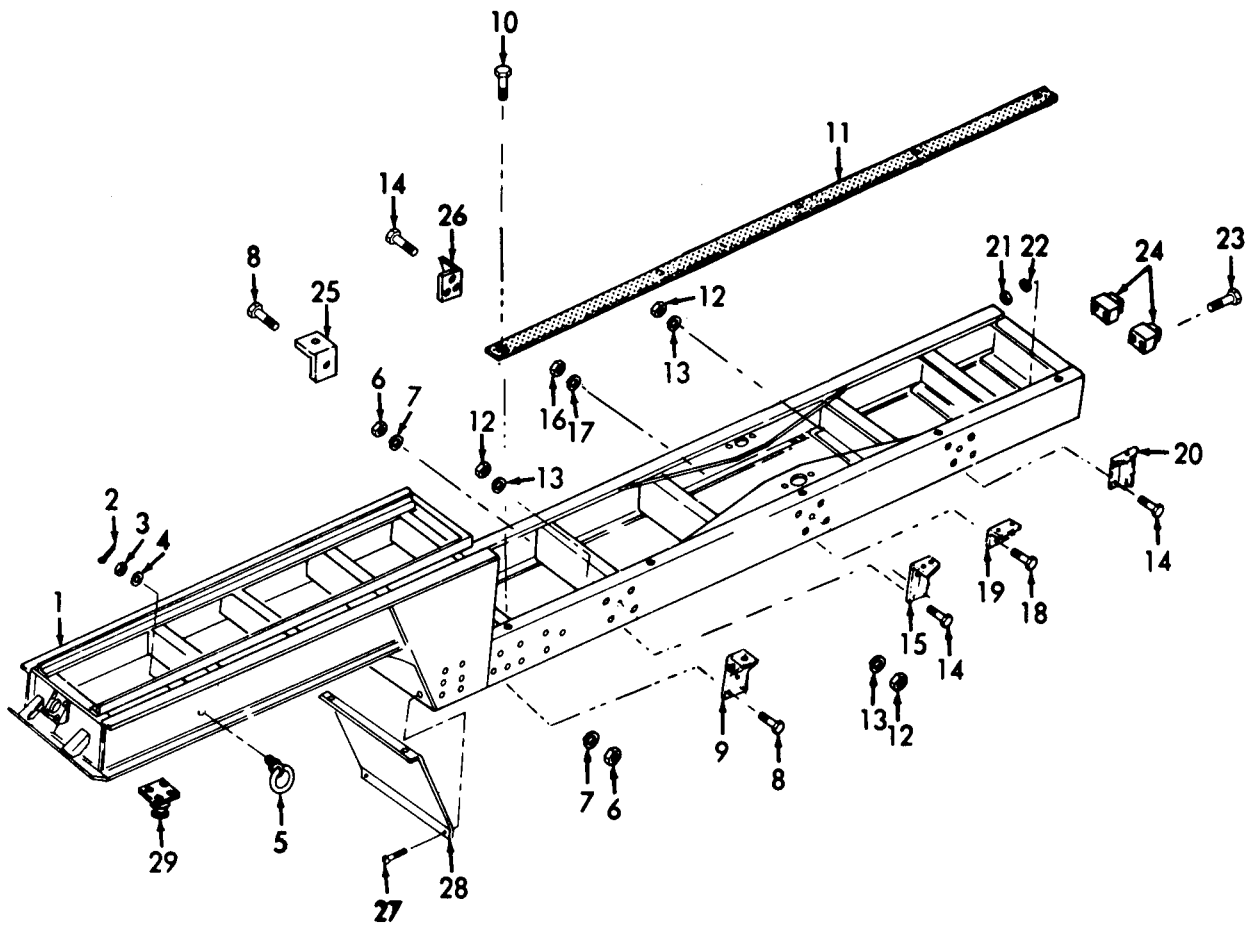


Figure 19-16. Frame and Brackets.

## LEGEND FOR FIGURE 19-16:

ITEM	NSN	P/N	FSCM	QTY
1. Frame Chassis		13217E0480	59678	1
2. Pin	5315-00-187-9567	MS24665-500	96906	8
3. Nut, Plain	5310-00-762-6213	MS51968-32	96906	8
4. Washer, Flat		13217E0601-1	59678	7
4. Washer, Flat		13217E0601-2	59678	1
5. Tie Down Chassis		13217E1116	59678	8
6. Nut, Plain	5310-00-763-8920	MS51967-20	96906	10
7. Washer, Lock	5310-00-820-6653	MS35338-50	96906	10
8. Screw, Cap	5305-00-727-3804	MS90725-165	96906	10
9. Bracket, Front LH		13217E0534	59678	1
10. Screw, Tapping	5305-00-292-7947	MS24627-66	96906	8
11. Sill, Chassis		13217E0537	59678	2
12. Nut	5310-00-768-0318	MS51967-14	96906	18
13. Washer, Lock	5310-00-584-5272	MS35338-48	96906	18
14. Screw, Cap	5305-00-042-6417	MS90725-113	96906	16
15. Bracket, Center LH		13217E0531	59678	1
16. Nut, Plain	5310-00-763-8921	MS51967-23	96906	4
17. Washer, Lock	5310-00-584-7888	MS35338-51	96906	4
18. Screw, Cap	5305-00-071-1766	MS90725-108	96906	4
19. Bracket, Chassis		13217E0535	59678	2
20. Bracket, Rear		13217E0539	59678	2
21. Nut, Self-Locking	5310-00-959-1488	MS51922-21	96906	8
22. Washer, Flat	5310-00-080-6004	MS27183-14	96906	4
23. Screw, Cap	5305-00-269-2810	MS90726-68	96906	8
24. Bumper, Rubber		13217E0491	59678	2
25. Bracket, Front RH		13217E0533	59678	1
26. Bracket, Center RH		13217E0532	59678	1
27. Screw, Tapping	5305-00-052-6921	MS24629-57	96906	6
28. Shield, Air Intake		13217E0559	59678	1
29. Kingpin, Fifth Wheel		MS53036-1	96906	1

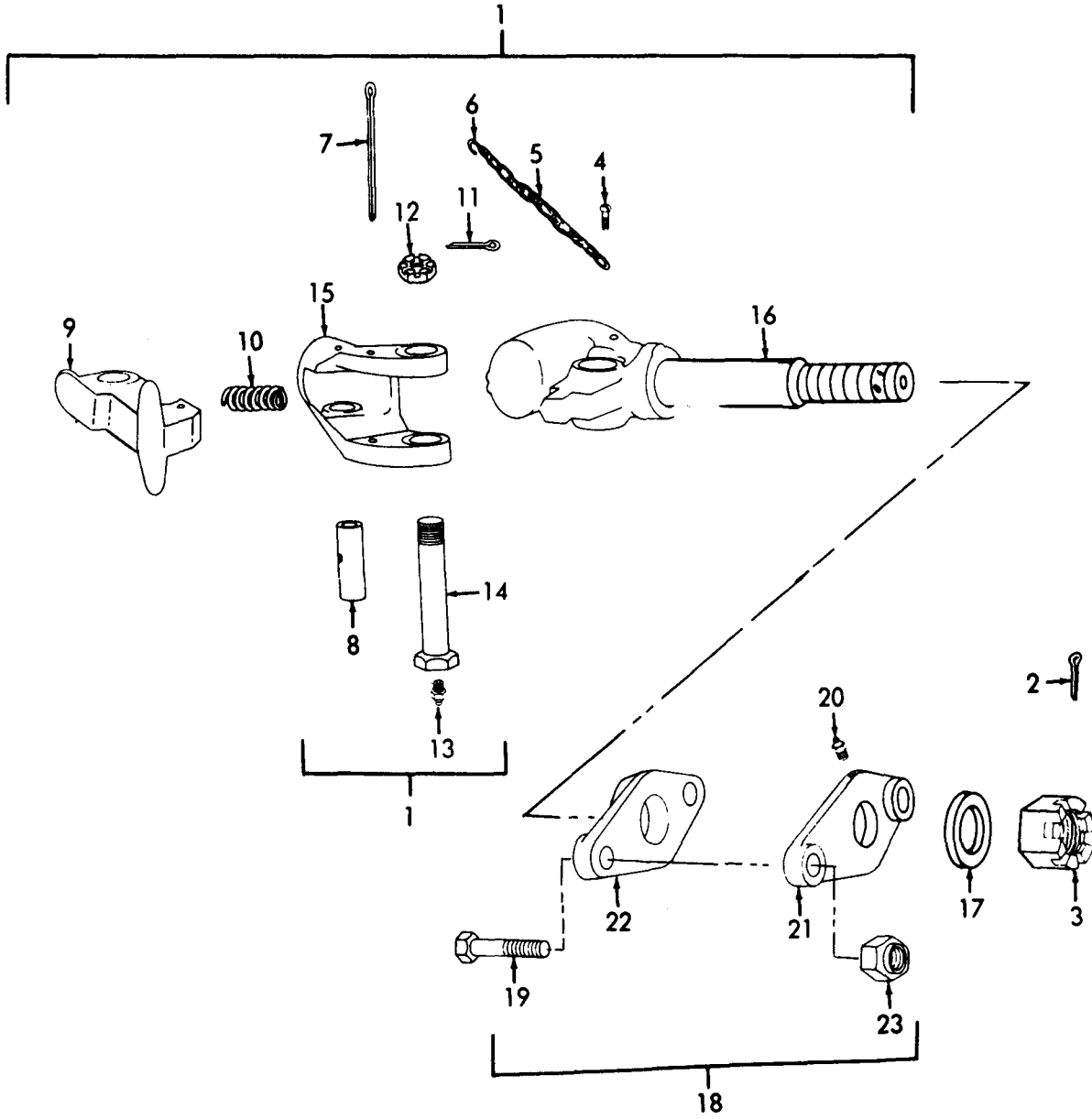


Figure 19-17. Towing Pintle.

## LEGEND FOR FIGURE 19-17:

ITEM	NSN	P/N	FSCM	QTY
1. Pintle Assy, Towing	2540-00-776-0103	MS51118-1	96906	1
2. Pin, Cotter	5315-00-846-0126	MS24665-628	96906	1
3. Nut, Plain, Slotted Hook	5310-00-842-7634	MS35692-109	96906	1
4. Screw	5305-00-253-5626	MS21318-47	96906	1
5. Chain, Cotter Pin, Retaining		42C15117-10	00000	1
6. Hook, S Chain		MS87006-21	96906	1
7. Pin, Cotter Hook to Lock	5315-00-234-1848	MS23665-629	96906	1
8. Pin		7714881	19207	1
9. Lock		7049603	19207	1
10. Spring	5360-00-704-4253	7044253	19207	1
11. Pin	5315-00-298-1481	MS24665-357	96906	1
12. Washer, Flat	5310-00-883-9384	MS15795-842	96906	1
13. Fitting	4730-00-172-0010	MS15002-1	96906	1
14. Bolt, Latch		7725844	19207	1
15. Latch	2540-00-237-3693	7714880	19207	1
16. Hook, Pintle		7760104	19207	1
17. Washer	5310-00-776-0105	768	74410	1
18. Bracket Assy, Pintle		13217E0492	59678	1
19. Screw	5305-00-948-0803	MS90727-191	96906	2
20. Fitting	4730-00-050-4203	MS15001-1	96906	2
21. Bracket, Inner Pintle		763	74410	1
22. Bracket, Outer Pintle		763A	74410	1
23. Nut	5310-00-832	MS51922-61	96906	2

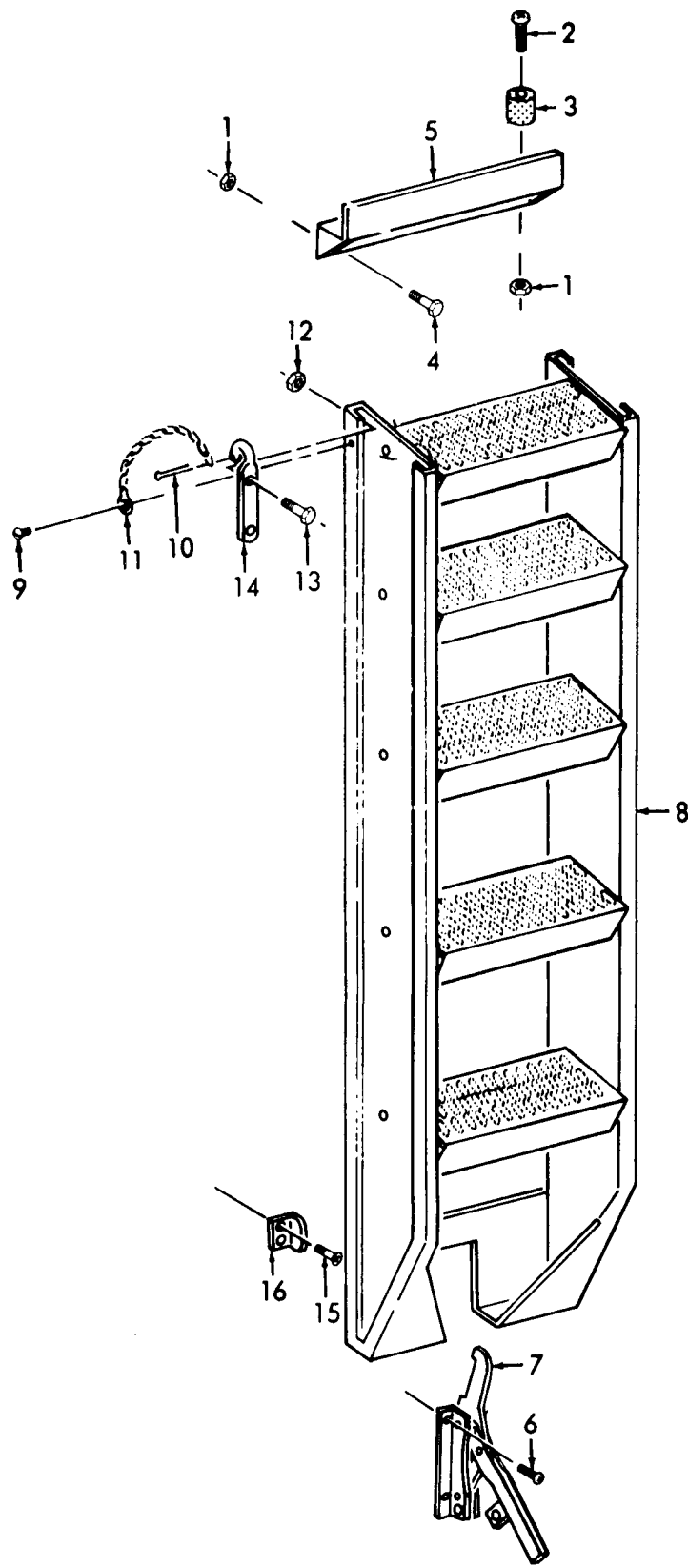
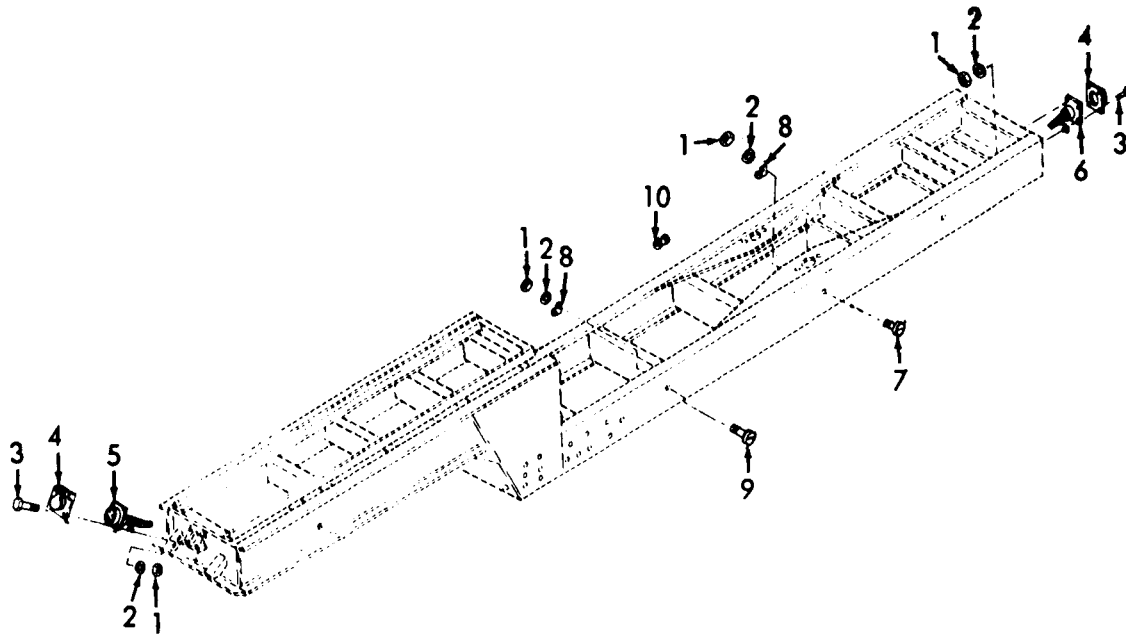


Figure 19-18. Front Ladder.

## LEGEND FOR FIGURE 19-18:

ITEM	NSN	P/N	FSCM	QTY
1. Nut, Self-Locking	5310-00-088-1251	MS51922-1	96906	2
2. Screw, Cap	5305-00-071-2237	MS90725-14	96906	2
3. Grommet, Bumper		13217E0512	59678	2
4. Screw, Cap	5305-00-225-3839	MS90725-8	96906	4
5. Rack, Engine Housing		13217E0514	59678	1
6. Screw	5305-00-052-6923	MS24629-59	96906	4
7. Clamp, Ladder		13217E0516	59678	1
8. Ladder, Vehicle Boarding		MS500062F2	96906	1
9. Screw	5305-00-432-4103	144721	19207	2
10. Pin	5315-00-012-0123	MS24665-355	96906	2
11. Chain, Weldless	4010-00-725-8401	42C16555	19204	2
12. Nut, Plain	5310-00-880-7744	MS51967-5	96906	4
13. Bolt, Machine	5306-00-225-8499	MS90725-34	96906	4
14. Hook, Ladder		10919617	19207	2
15. Screw, Tapping	5305-00-855-0964	MS24629-48	96906	2
16. Angle, Ladder		13217E0513	59678	2



LEGEND FOR FIGURE 19-19:

ITEM	NSN	P/N	FSCM	QTY
1. Nut, Plain	5310-00-761-6882	MS51967-2	96906	18
2. Washer, Lock	5310-00-582-5965	MS35338-44	96906	21
3. Screw, Cap	5303-00-225-3840	MS90725-7	96906	8
4. Cover		13214E2246	97403	2
5. Cable Assy, 24 Vdc Front		13217E0911	59678	1
6. Cable Assy, 24 Vdc Rear		13217E0908	59678	1
7. Screw, Machine	5305-00-988-1727	MS35206-283	96906	4
8. Clamp, Loop Wiring Harness	5340-00-282-7537	MS21333-41	96906	13
9. Screw, Machine	5305-00-988-1725	MS35206-281	96906	8
10. Grommet, Rubber Wiring Harness		13217E0909	59678	1

Figure 19-19. Frame and Wiring.



## APPENDIX A

### REFERENCES

---

#### A-1. MAINTENANCE.

DA PAM 738-750	Maintenance Management Update
TM 5-764	Electric Motor and Generator Repair
TM 5-4520-227-14	Operator's Manual for Heater, Space
TM 9-237	Operator's Manual for Welding Theory and Application
FM 10-16	General Repair of Tents, Canvas, and Webbing (GPO SN: 0820-00501-1)

#### A-2. DESTRUCTION.

TM 750-244-3	Procedures for destruction of equipment to Prevent enemy use.
--------------	---

#### A-3. SHIPMENT AND STORAGE.

TM 740-90-1	Administrative Storage of Equipment.
-------------	--------------------------------------

#### A-4. COMMERCIAL TECHNICAL MANUALS.

Cutter Bolt	Form ID202, FSCM 77428; Part No. 0390 MA Instructions.
Drill, Elec. Port., 3/4 In.	FSCM 07429, Part No. 1405-81, Manual 42499-02, Dated 10-76 and Parts List 97295-01, Dated 3-78.
Drill, Elec. Port., 1/2 In.	FSCM 07429, Part No. 7204, Manual 97351 and Parts List 97187-03, Dated 8/80.
Drilling Machine, Upright	FSCM 80318, Part No. 70-323, Manuals 402-06-651-5007, Dated 3/1/78 and 438-01-655-5021, Dated 3/10/77.
Flood Light	FSCM 08998, Part No. 150SWT, Servicing Instructions Sheet 1024SWT.
Grinding Kit, Valve Seat	FSCM 07429, Part No. 6635-66, Manual 44144-02, Dated 2/79, and Parts List 97257-02, Dated 9/75.

- Grinding Machine, Utility  
FSCM 05472, Part No. 1022W, Manual 44144-02, Dated 8/79, and Parts List 145H, Dated 4/30/80.
- Grinding Machine, Valve Face  
FSCM 07429, Part No. 6305-67, Manual 44144-02, Dated 6/77, and Parts List 97257-02, Dated 9/75.
- Hoist Chain FSCM 27404, Part No. NBR-1X10FT, Parts List and Assembly Data, No. 419-A, Dated 7/1/76.
- Honing Machine, Horizontal  
FSCM 23148, Model CHY-AE, Manual C8-IIA, Dated 4179.
- Indicator, Corm Rod Align  
FSCM 83658, Model U-30, Operating Instructions and Parts List.
- Jack, Hyd, Hand, 20 Ton  
FSCM 79260, Part No. 93233, Manual 10357C, Dated 10/81.
- Lathe, Engine FSCM 55985, Part No. SS4066, Operation and Maintenance Manual 27" Turn-nado, Bulletin 8007.
- Mill, Grind, Drill, Slot, Atch  
FSCM 59396, Series 32, Operation and Service Manual, R884-0201, Dated 4/77.
- Moisture Stabilizer FSCM 81493, Type 50A, Model 9, Handbook of Instructions N54015E, DATED 3/82.
- Puller Kit, 100 Ton Capacity  
FSCM 45225, Part No. Y11000, Operating and Service Instructions for Hydraulic Pump, Form No. 102355, Dated 12/20/79.  
  
Parts List for Hydraulic Pump, Form No. 100360, Dated 6/1/81.  
  
Parts List for Hydraulic Cylinder, Form No. 100311, Dated 8/1/79.
- Puller Kit, 50 Ton FSCM 45225, Part No. Y10000 MOD  
  
Parts List for Hydraulic Hand Pump, Form No. 100390, Dated 3110/80.  
  
Parts List for Valve Assembly, Form No. 100389, Dated 11/26/79, and Form No. 100388, Dated 11/19/79.  
  
Parts List for No. Y-50 Power-T win Hydraulic Ram, Cat. No. Y-50, Dated 10/30/78.  
  
Instruction Manual, Manual No. 13008, Dated 1963.

**Puller Kit, Mechanical**

FSCM 55719, Part No. A-57, Instruction Sheet, SB-215B, Dated 4/73

**Puller Kit, Universal**

FSCM 45225, Part No. Y9000

**Riveter, Blind, Pneumatic**

FSCM 29666, Part No. 350-52, Instruction Manual, Form No. 452, Dated 2/74 and Parts List, Page No. 6-007, Dated 12/70.

**Riveter Kit, Brake Hand**

FSCM 34929, Part No. PR100, Parts Listing, Instruction Manual.

**Sander, Disc**

FSCM 07429, Part No. 4049, Manual 724056-03, Dated 4/81, Parts List 724060-03, Dated 6-79.

**Saw, Band, Port, Electric**

FSCM 83738, Part No. 7721, Parts Lists 861836-189 and 861832-871.

**Saw, Reciprocator, Electric**

FSCM 07492, Part No. 3103-09, Manual 722821, Dated 2/76, and Parts List 740708, Dated 4/81.

**Spray Outfit, Paint**

FSCM 07334, Part No. Model 18, Operating Instructions and Parts List Manual 1249R-9, Dated 4/77, Manual 1234R-3, Dated 1/71, and Manual 1977, Dated 6/71.

**Tachometer, Mechanical, Hand**

FSCM 32480, Part No. 4800, Operating Instructions, Type IC/BPA.

**Test Set, Diesel Injector**

FSCM 33559, Part No. MIL-8265, Instruction and Parts List, Model DT-1300, Kiene Diesel Hydraulic-Tester, and Instruction and Parts List, Unit Injector Test Stand, Models TS-10 and TS-15.

**Tester, Cylinder Compression**

FSCM 33559, Model C400/4300, Instructions Dated 10/67.

**Tool Kit, Pin Remove and Replace**

FSCM 45225, Part No. Y12000, Manual 14066, Dated 4/73.

**Wrench, Impact, Electric**

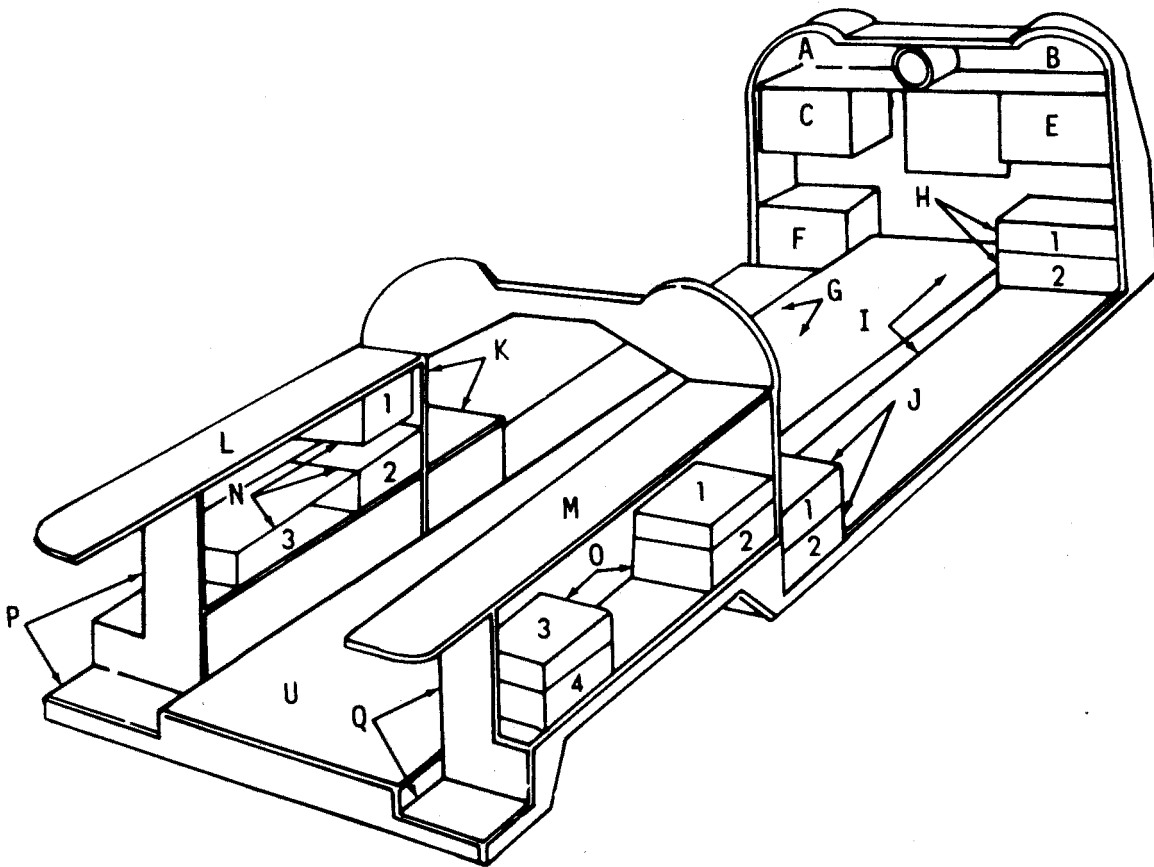
FSCM 30760, Part No. 8UG7, Instructions and Parts List, R-2330, Rev, July 1981.



APPENDIX B

SHOP SET TOOL LOCATION LOADING AND PACKING LIST

---



B-1. Shop Set Location.

## SHOP SET CONTENTS

NSN	DESCRIPTION	QTY.	LOC.
8120-00-695-5867	Adapter, Comp Gas, CL200-510	1 EA	0
8120-00-695-6001	Adapter, Comp Gas, CL200-520	1 EA	0
8120-00-264-5530	Adapter, Comp Gas, CL300-510	1 EA	0
8120-00-695-6044	Adapter, Comp Gas, CL510-200	1 EA	0
8120-00-264-5531	Adapter, Comp Gas, CL510-300	1 EA	0
8120-00-695-5983	Adapter, Comp Gas, CL520-510	1 EA	0
5935-00-081-8025	Adapter, Connector, 125V	6 EA	L
5935-00-833-5046	Adapter, Connector, 250V	6 EA	L
5130-00-293-2330	Adapter, Spindle, Sander	1 EA	0
5120-00-180-2885	Anvil, Blacksmith's	1 EA	U
8415-00-250-2531	Apron, Welder's	1 EA	01
5330-00-233-5842	Asbestos Sheet, Woven	1 SH	01
5120-00-221-1542	Awl, Scratch	1 EA	O
5110-00-720-0711	Ax, Single Bit	1 EA	E
5120-00-224-1389	Bar, Pry	1 EA	0
5120-00-808-6191	Bender, Tube, Hand	1 EA	C
5120-00-293-0019	Bender Set, Tube	1 SE	L
5210-00-278-0645	Bevel, Sliding T	1 EA	0
5110-00-243-0901	Blade, Hacksaw, 24TPI. 10/Bd1	3 BN	0
5120-00-221-1637	Block, Dolly, Sheet Metal	1 EA	0
7610-00-233-9600	Book, American Electrician's	1 EA	E
7610-00-250-6629	Book, Machine Tool Operation	1 EA	E
7610-00-577-5888	Book, Refr & Air Cond	1 EA	E
7610-00-059-6718	Book, American Machinist	1 EA	E
7610-00-232-8354	Book, Welding Encyclopedia	1 EA	E
3439-00-528-3882	Brazing Alloy, Silver	8 EA	E
7920-00-291-8305	Broom, Upright	1 EA	L
7920-00-240-6358	Brush, Dusting, Bench	1 EA	01
7920-00-224-7987	Brush, File Cleaner	1 EA	0
5130-00-630-4435	Brush, Wire, Rotary Wheel	1 EA	01
6150-00-866-2358	Cable, Power, Elec	1 EA	B
5210-00-229-3026	Caliper, Hermaphrodite	1 EA	0
+5210-00-189-9639	Caliper, Inside, 10 In L	1 EA	0
5210-00-229-3076	Caliper, Inside, 3 In L	1 EA	0
+5210-00-229-3051	Caliper, Inside, 6 In L	1 EA	0
>5210-00-221-1921	Caliper, Mic, Inside	1 SE	01
>5210-00-540-2973	Caliper, Mic, Outside, 0-1 In	1 EA	0
>5210-00-243-2933	Caliper, Mic, Outside, 1-2 In	1 EA	0
+5210-00-221-1945	Caliper, Mic, Outside, 2-3 In	1 EA	0
>5210-00-221-1934	Caliper, Mic, Outside, 3-4 In	1 EA	0
+5210-00-255-7564	Caliper, Mic, Outside, 4-5 In	1 EA	0
+5210-00-221-1948	Caliper, Mic, Outside, 5-6 In	1 EA	0
5210-00-229-3035	Caliper, Outside, 12 In L	1 EA	0
+5210-00-229-3047	Caliper, Outside, 4 In L	1 EA	0
+5210-00-229-3048	Caliper, Outside, 6 In L	1 EA	0
5210-00-221-2091	Caliper, Slide	1 EA	0
5210-00-227-7549	Caliper, Vernier, 0-6 In	1 EA	0
5210-00-293-2913	Caliper, Vernier, 0-12 In	1 EA	01
4010-00-176-7937	Chain Assembly, Single Leg	2 EA	M
5110-00-223-1079	Chisel, Diamond Point	1 EA	0

NSN	DESCRIPTION	QTY.	LOC.
5110-00-585-8427	Chisel, Butt, 1/2 In W	1 EA	0
5110-00-585-8428	Chisel, Butt, 3/4 In W	1 EA	0
5120-00-180-0905	Clamp, C, 2 In	4 EA	01
5120-00-222-1612	Clamp, C, 4 In	4 EA	E
5120-00-840-3358	Clamp, C, 8 In	4 EA	B
5120-00-595-8274	Clamp, C, 8 In, 12 In Deep	1 EA	B
5999-00-913-0883	Clamp, Electrical, Bronze	1 EA	0
5940-00-679-9547	Clip, Electrical	1 EA	0
5120-00-494-1895	Clamp, Plier	2 EA	01
5120-00-799-3398	Cleaner, Piston Ring Groove	1 EA	0
3439-00-383-3634	Cleaner Set, Weld & Cut Tips	1 SE	0
3439-00-403-0970	Cleaner Set, Weld & Cut Tips	1 SE	0
5350-00-192-5047	Cloth, Abrasive Gr 80, 50 Sh	1 SV	02
5350-00-192-5051	Cloth, Abrasive Gr 180, 50 Sh	1 SV	02
5640-00-292-7421	Cloth, Asbestos	1 EA	02
5120-00-250-6055	Compressor, Pstn R, 2 Bnd, Sz 1	1 EA	01
5120-00-894-0753	Compressor, Pstn R, 4 Bnd, Sz 2L	1 EA	02
5120-00-516-4226	Compressor, Valve Spring	1 EA	L
5133-00-239-0785	Countersink, Pilotless	1 EA	0
5133-00-293-0853	Countersink, Str Rnd Shk, 60 Deg	1 EA	0
5133-00-247-2818	Countersink, Str Rnd Shk, 82 Deg	1 EA	0
4730-00-142-1958	Coupling Half, AN6027-1	1 EA	0
4730-00-320-1887	Coupling Half, M4109-121224C	3 EA	0
4730-00-176-4293	Coupling Half, M4109-041224C	3 EA	0
4730-00-176-4294	Coupling Half, M4109-091200C	2 EA	0
7510-00-223-6708	Crayon Marking, 144/Bx	1 GR	01
5120-00-224-1344	Crowbar, 35-37 In L	1 EA	L
5120-00-240-6040	Crowbar, 47-49 In L	1 EA	L
5110-00-224-7057	Cutter Bolt	1 EA	0
5110-00-595-8278	Cutter, Glass, Circle	1 EA	C
5110-00-222-4401	Cutter, Glass, Line	2 EA	01
3455-00-542-4021	Cutter, Hole, Taper Shank	1 EA	N
5133-00-224-1965	Ctr, Hole Forming 1/8 In Dia	1 EA	0
5133-00-228-2323	Ctr, Hole Forming 7/32 In Dia	1 EA	0
3455-00-542-4019	Cutter, Mill End, 3/16 In Dia	1 EA	0
3455-00-516-3151	Cutter, Mill End, 1/4 In Dia	1 EA	0
3455-00-228-5238	Cutter, Mill End, 3/8 In Dia	1 EA	0
3455-00-228-5217	Cutter, Mill End, 1/2 In Dia	1 EA	0
3455-00-224-3655	Cutter, Mill Slit, 3/32 In W	1 EA	0
3455-00-224-3657	Cutter, Mill Slit, 1/8 In W	1 EA	0
3455-00-231-3474	Cutter, Mill, 1/2 In	1 EA	0
3455-00-194-0529	Cutter, Mill, 5/16 In	1 EA	0
3455-00-232-9033	Cutter, Mill, Side, 1/4 In	1 EA	0
3455-00-232-9034	Cutter, Mill, Side, 3/8 In	1 EA	0
5180-00-596-1038	Cutter & Flaring Tool Kit, Tb	1 EA	L
3455-00-272-9860	Cutter Bit, Tool, 1/8 In Thk	6 EA	N
3455-00-516-3162	Cutter Bit, Tool, 1/4 In Thk	12 EA	0
3455-00-272-9782	Cutter Bit, Tool, 3/16 In Thk	12 EA	0
3455-00-272-9784	Cutter Bit, Tool, 5/16 In Thk	12 EA	N
3455-00-272-9785	Cutter Bit, Tool, 3/8 In Thk	24 EA	0
3455-00-272-9787	Cutter Bit, Tool, 1/2 In Thk	1 EA	01
3455-00-516-3149	Cutter Set, Mill, Woodruff Key	1 EA	01
9150-00-231-6699	Cutting Fluid	4 PT	02
8120-00-268-3360	Cylinder, Compressed Gas	2 EA	P,Q
8120-00-282-8083	Cylinder, Compressed Gas	3 EA	P,Q

NSN	DESCRIPTION	QTY.	LOC.
5110-00-293-1905-	Die Set, Metal Stamping	1 SE	02
5345-00-196-1698-	Disk, Abrasive, Al Oxd, Gr 80	1 BX	02
5345-00-196-1692-	Disk, Abrasive, Al Oxd, Gr 36	4 EA	02
5345-00-558-5928	Disk, Abrasive, Al Oxd, Gr 24	4 EA	02
5345-00-558-5929-	Disk, Abrasive, Al Oxc, Gr 16	1 BX	02
5210-00-293-3732-	Divider-Caliper, Mechanic's	1 EA	0
5210-00-263-0378-	Dividers, Mechanic's	1 EA	0
5120-00-223-9952-	Dresser, Abrasive Wheel	1 EA	N
5345-00-250-1345-	Dresser, Contact Point	1 DZ	0
5120-00-293-0993-	Drift Set, Drill	1 EA	0
5130-01-087-6828-	Drill, Electric Port, 3/4 In	1 EA	L
5130-00-177-7001-	Drill, Electric Port, 1/4 In	1 EA	03
5130-00-283-3231-	Drill, Electric Port, 1/2 In	1 EA	M
5133-00-293-1161-	Drill, Set, Twist, 49/64 thru 1	1 SE	E
5133-00-542-4001-	Drill, Set, Tw, 1-1/32 thru 1-1/4	1 SE	E
5133-00-293-0983-	Drill, Set, Tw, 1/16 thru 1/2	1 SE	N
5133-00-449-6775	Drill, Set, Twist, No. 1-60	1 SE	0
5133-00-596-8088-	Drill, Set, Twist, 33/64 thru 3/4	1 SE	E
5133-00-266-9464-	Drill, Twist, 9/16 In Dia	1 EA	0
5133-00-266-9466-	Drill, Twist, 5/8 In Dia	1 EA	0
3414-00-026-1250-	Drilling Machine, Upright	1 EA	K
4720-00-223-7381-	Duplex Hose, Rubber	1 EA	A
3439-00-262-2598-	Electrode Weld, Al Alloy	25 LB	M
3439-00-200-1370-	Electrode, Weld, Bronze	20 LB	N
3439-00-528-9064-	Electrode, Weld, Cres	10 LB	B
3439-00-262-2639-	Electrode, Weld, 3/16 In Dia	50 LB	N
3439-00-262-2743-	Electrode, Weld, Nkl Alloy	50 LB	N
3439-00-262-2671-	Electrode, Weld, 5/32 In Dia	50 LB	0
4910-00-363-7535-	Expander, Crankshaft, Seal	1 EA	E
5120-00-393-0540-	Expander, Piston Ring	1 EA	0
4210-00-262-7858	Extinguisher, Fire, Carbon	1 EA	N
5120-00-540-1410-	Extractor Set, Screw	1 SE	N
5120-00-540-4273-	Face, Hammer, Inserted, Hard	1 EA	0
5120-00-357-5864-	Face, Hammer, Inserted, Mdm Hard	1 EA	0
5120-00-293-2997-	Face, Hammer, Inserted, Tough	1 EA	0
5110-00-204-0616-	File, Crosscut, 8 In L	1 EA	N
5110-00-234-6539-	File, Bastard, 12 In L	1 EA	N
5110-00-203-5463-	File, Bastard, 16 In L	1 EA	N
5110-00-203-4855-	File, Flat, 2nd Cut, 12 In L	1 EA	N
5110-00-203-4935-	File, Flat, Smooth, 8 In L	1 EA	N
5110-00-203-4936-	File, Flat, Smooth, 12 In L	1 EA	N
5110-00-252-4015-	File, Half Rnd, Bastard, 12 In L	1 EA	N
5110-00-203-4941-	File, Half Rnd, 2nd Cut, 12 In L	2 EA	N
5110-00-241-9156-	File, Half Rnd, Smooth, 12 In L	1 EA	N
5110-00-234-6551-	File, Rnd, Bastard, 8 In L	1 EA	N
5110-00-234-6557-	File, Rnd, Bastard, 1/2 In Dia	1 EA	N
5110-00-239-6898-	File, Rnd, Bastard, 3/4 In Dia	1 EA	N
5110-00-234-6559-	File, Rnd, Smooth, 1/2 In Dia	1 EA	N
5110-00-234-6528-	File, Slim Taper, 6 In L	1 EA	N
5110-00-234-6529-	File, Slim Taper, 8 In L	3 EA	N
5110-00-238-9664-	File, Square, Bastard, 12 In L	2 EA	N
5110-00-203-9804-	File, Square, Smooth, 10 In L	1 EA	N



NSN	DESCRIPTION	QTY.	LOC.
5110-00-204-2685	File Set, Hand	1 SE	0
6545-00-922-1200	First Aid Kit, Genl Purpose	1 EA	02
4730-00-470-6625	Fitting Kit, Tube-Pipe	1 EA	M
5120-00-965-0603	Flint Tip, Igniter, 6/Bx	1 BX	0
6230-00-815-5022	Floodlight, Electric	2 EA	L
3439-00-914-8390	Flux, Brazing	1 EA	04
3439-00-255-4566	Flux, Soldering, 1/4 Lb Can	1 CN	0
3439-00-255-4577	Flux, Welding, 1 Lb	2 CN	04
5110-00-289-9657	Frame, Hand Hacksaw	1 EA	N
3442-00-690-8076	Frame, Hydr Press, 17-1/2 Ton	1 EA	J
3442-00-690-8077	Frame, Hydr Press, 50 Ton	1 EA	P
5210-00-222-4000	Gage, Center	1 EA	04
5210-00-619-4045	Gage, Depth, Micrometer	1 EA	02
5210-00-221-1902	Gage, Depth, Rule	1 EA	0
5210-00-221-2072	Gage, Drill Point	1 EA	0
5210-00-221-1991	Gage, Screw Pitch, Metric	1 EA	0
5210-00-293-1872	Gage, Screw Pitch, V Form	1 EA	0
5210-00-221-1842	Gage, Surface	1 EA	03
5210-00-517-8097	Gage, Thickness	1 EA	0
4910-00-204-3170	Gage, Tire Pressure	1 EA	0
5210-00-221-1894	Gage, Twist, Drill & Tap	1 EA	0
5210-00-473-9350	Gage Set, Telescoping	1 SE	N
8040-00-664-4134	Gasket Shellac Compound	1 PT	03
8415-00-268-7859	Gloves, Welders'	4 PR	C
4240-00-269-7912	Goggles, Industrial	1 PR	03
4240-00-203-3804	Goggles, Industrial, Welder's	2 PR	03
4910-00-473-6437	Grinding Kit, Valve Seat	1 EA	N
3415-00-255-2683	Grinding Machine, Utility	1 EA	G
4910-00-540-4679	Grinding Machine, Valve Face	1 EA	M,N,O
4940-00-333-5541	Gun, Air Blow	1 EA	0
4930-00-222-2680	Gun, Fluid, Direct	1 EA	03
5120-00-902-0092	Hammer, Blacksmith's, 2 Lb	1 EA	03
5120-00-900-6103	Hammer, Blacksmith's, 3 Lb	1 EA	03
5120-00-900-6096	Hammer, Blacksmith's, 8 Lb	1 EA	0
5120-00-903-7129	Hmr, Bodyworker's Ding, 14 Oz	1 EA	03
5120-00-892-5485	Hammer, Carpenter's, 1 Lb	1 EA	03
5120-00-900-6111	Hammer, Machinist's, 3 Lb	1 EA	03
5120-00-900-6076	Hammer, Tinner's, 1 Lb	1 EA	03
5120-00-585-2383	Hammer, Welder's, 14 Oz	1 EA	03
5110-00-263-0349	Handle, File, 1-1/4 In Dia	4 EA	0
5110-00-263-0341	Handle, File, 1-1/2 In Dia	4 EA	0
4240-00-540-0623	Helmet, Welder's	1 EA	C
3950-00-235-4235	Hoist, Chain	1 EA	M
X3439-00-238-1638	Holder, Electrode, Welding	1 EA	N
5120-00-554-7757	Holder, Inserted Hammer Face	1 EA	03
3419-00-812-1591	Honing Machine, Horizontal	1 EA	M,O
4720-00-202-6927	Hose, Rubber, 3/8 In ID	100 FT	A
5120-00-965-0326	Igniter, Friction	1 EA	0
4910-00-733-2487	Indicator, Conn Rod Align	1 EA	03
5210-00-277-8840	Indicator Dial	1 EA	03
4910-00-204-2644	Inflator Gage, Pneu Tire	1 EA	N
2910-00-146-9619	Injector Tube Reconditioning	1 EA	04

NSN	DESCRIPTION	QTY.	LOC.
5340-01-008-6652	Insert Special	1 AT	04
5970-00-644-3167	Insulation Tape, Elec, Cotton	1 RO	0
5970-00-184-2002	Insulation Tape, Elec, Rubber	1 RO	0
6850-00-664-0355	Isolating Paste, 2 GL	2 CN	L
5120-00-188-1788	Jack, Hyd, Hand, 20 Ton	1 EA	K
5120-00-224-7330	Jack, Hyd, Hand, 12 Ton	1 EA	K
3460-00-238-3079	Jack, Planer	2 EA	04
5180-00-494-8156	Kit, Screw Thread Insert	1 EA	N2
5110-00-240-5943	Knife, Pocket	2 EA	0
6240-00-155-8634	Lamp, Incandescent, 50W	8 EA	M
6240-00-553-1881	Lamp, Incandescent, 300W	6 EA	M
5120-00-289-0502	Lapper, Poppet Valve, Hand	1 EA	C
5350-00-221-0692	Lapping and Grinding Cmpd	2 CN	0
3416-01-034-1257	Lathe, Engine	1 EA	J,K,U
6150-00-242-3715	Lead, Elec, Copper 10 AWG	5 EA	B
6150-00-665-9799	Lead, Elec, Copper, 1/0 AWG	2 EA	E
4240-00-262-7092	Lens, Goggles, Industrial	6 PR	0
4240-00-203-7764	Lens, Helmet, Welder's	12 EA	E
4240-00-276-8940	Lens, Helmet, Welder's Fltr	12 EA	0
5210-00-277-2430	Level and Plumb	1 EA	04
5120-00-542-3485	Lifter, Valve, Spring, Small	1 EA	N
5120-00-239-8686	Lifter, Valve Spring	1 EA	L
6230-00-901-9755	Light, Extension, 3 Cndct	2 EA	A
4930-00-253-2478	Lubricating Gun, Hand	1 EA	C
3460-00-516-3055	Mandrel Set, 1-1/2 thru 3-3/4	1 EA	L
3460-00-516-3645	Mandrel Set, Machine, Solid	1 EA	0
9530-00-230-3476	Metal Bar, Copper Alloy	1 FT	03
3460-00-540-1824	Mill, Grind, Drill, Slot, Atch	1 EA	F1,F2 H,J,M
3439-00-440-0090	Moisture Stabilizer, 50 Lb	1 EA	L
5110-00-221-1499	Nippers, End Cutting	1 EA	0
9390-00-274-3843	Nonmetallic Rod	2 EA	0
4930-00-554-6778	Oiler, Hand	3 EA	E
5330-00-247-0510	Packing Material, 1/2 Lb	1 RO	N
5340-00-291-4214	Padlock Set	1 SE	H1
7240-00-160-0455	Pail, Metal	1 EA	L
5330-00-467-3615	Paper Gasket, 1/32 In Thk	6 FT	L
5330-00-270-8470	Paper Gasket, 1/16 In Thk	2 SY	L
7510-00-275-7213	Pencil	1 DZ	0
8010-00-551-0128	Pigment, Iron Blue	1 TU	0
5315-00-017-9252	Pin, Cotter 1/16 X 1	1 HD	0
5315-00-816-1794	Pin, Cotter 3/32 X 1	1 HD	0
5315-00-012-0123	Pin, Cotter 1/8 X 1-1/4	1 HD	0
5315-00-298-1499	Pin, Cotter 1/8 X 2	1 HD	0
5120-00-789-0491	Plate, Adapter	1 EA	0
5120-00-239-8251	Pliers, Lineman's	2 EA	N
5120-00-293-0049	Pliers, Retaining Ring	1 EA	0
5120-00-789-0492	Pliers, Snap Ring	1 EA	0
4910-00-273-3660	Plug Set, Radiator Test	1 EA	04
5120-00-417-2952	Puller, Mech, Cylinder Sleeve	1 EA	U

NSN	DESCRIPTION	QTY.	LOC.
5120-00-293-1429	Puller, Mech, Gear & Bearing	1 EA	L
5120-00-230-9716	Puller Kit, 100 Ton Capacity	1 EA	N, I P, U
5180-00-786-1152	Puller Kit, 100 Ton	1 SE	I, P
5180-00-701-8046	Puller Kit, 17-1/2 & 30 Ton	1 EA	N, Q,
5120-00-089-3660	Puller Kit, Mechanical	1 EA	04
4320-00-055-2639	Pump, Unit, Reciprocating	1 EA	C, J
5120-00-595-9485	Punch, Align, 5/32 Dia Pt	2 EA	0
5120-00-242-0764	Punch, Drift, 3/8 Dia Pt	1 EA	0
5120-00-240-6082	Punch, Drive Pin, 1/16 Dia Pt	1 EA	0
5120-00-242-3435	Punch, Drive Pin, 3/32 Dia Pt	1 EA	0
5120-00-224-7446	Punch, Prick	1 EA	0
5110-00-449-7313	Punch Set, Hollow	1 SE	04
5110-00-237-8598	Reamer, Cylinder Ridge	1 EA	04
5110-00-595-9283	Reamer Set, Adjustable	1 SE	N1
5180-00-219-8398	Reamer Set, Injector	1 SE	04
5110-00-596-1151	Reamer Set, Taper Pin	1 SE	04
5110-00-595-9282	Reamer Set, Taper Pin, Spiral	1 SE	04
5120-00-219-8404	Remover & Replacer, V Guide	1 EA	N
5120-00-473-7393	Remover & Replace, Insr V	1 EA	N
5120-00-545-4268	Retrieving Tool, Magnetic	1 EA	0
5130-00-580-2305	Riveter, Blind, Pneumatic	1 EA	M
5180-00-600-1451	Riveter Kit, Brake Band	1 SE	L
5975-00-642-8937	Rod, Ground	1 EA	M
3439-00-244-4540	Rod, Welding, Brass	10 LB	0
3439-00-246-0550	Rod, Welding, Cast Iron	10 LB	0
3439-00-246-0566	Rod, Welding, Steel, 1/8 In	10 LB	0
3439-00-246-0568	Rod, Welding, Steel, 3/16 In	20 LB	0
4020-00-238-7732	Rope, Manila	100 FT	N3
5330-00-333-0313	Rubber Sheet, Cloth Insert	1 SY	L
5210-00-293-3393	Rule, Multiple Folding	1 EA	0
5210-00-234-5224	Rule, Machinist's, No. 4	1 EA	0
5210-00-725-7347	Rule, Machinist's, ME-2	1 EA	0
5130-00-596-9728	Sander, Disk, Electric, Port	1 EA	BV
5130-01-008-7418	Saw, Band, Port, Electric	1 EA	N
5130-00-819-7767	Saw, Reciprocator, Electric	1 EA	L
5110-00-293-0090	Saws, Nested	1 SE	N1
5120-00-278-1280	Screwdriver, F1 Tip, Flrd, 8 In L	1 EA	0
5120-00-278-1283	Screwdriver, F1 Tip, Flrd, 6 In L	1 EA	0
5120-00-287-2504	Screwdriver, F1 Tip, Flrd, 3 In L	1 EA	0
5120-00-236-2127	Screwdriver, F1 Tip, Flrd, 3 In L	1 EA	0
5120-00-278-1270	Screwdriver, F1 Tip, Flrd, 5 In L	1 EA	0
5120-00-222-8837	Screwdriver, Spark Testing	1 EA	0
5120-00-288-8739	Screwdriver Set, Jeweler's	1 SE	0
5120-00-224-9728	Scriber, Machinist's	3 EA	0
8030-00-291-1787	Sealing Compound, Nonhardening	1 PT	E
5110-00-289-8659	Shears, Metal Cutting	1 EA	0
4240-00-270-4415	Shield, Arc Viewing, Hand	1 EA	E
9515-00-243-1873	Shim Stock, Laminated	1 SH	M
3460-00-227-7507	Socket, Taper Shk, 3-9/16 In L	1 EA	0
3460-00-227-7520	Socket, Taper Shk, 4-7/16 In L	1 EA	0
3460-00-232-8117	Socket, Taper Shk, 3-7/8 In L	1 EA	N

NSN	DESCRIPTION	QTY.	LOC.
3460-00-227-7500-	Socket, Taper Shk, 5-3/8 In L	1 EA	N
5130-00-540-1825	Socket Set, Socket Wrench	1 SE	N1
3439-00-184-8960-	Solder, Lead Alloy, Acid	5 LB	N1
3439-00-243-1882-	Solder, Lead Alloy, Rosin	1 LB	N
3439-00-542-0531.	Soldering Torch Kit	1 EA	0
3439-00-223-2528-	Soldering Iron, Electric	1 EA	N1
3439-00-224-7509-	Soldering Iron, NonElectric	1 EA	N1
4940-00-857-2290	Spray Outfit, Paint	1 EA	L
5210-00-273-1948-	Square, Carpenter's	1 EA	L
5210-00-078-8944-	Square, Combination, 6 In L	1 EA	N1
5210-00-078-8949-	Square, Combination, 12 In L	1 EA	N1
5345-00-161-9695-	Stone, Sharpening	1 EA	N
6680-00-171-4584	Tachometer, Mechanical, Hand	1 EA	N2
5136-00-596-1521	Tap Set, Thread Cut, NPT, CS	1 EA	N2
5136-00-596-1205	Tap Set, Thread Cut	1 SE	M
5315-00-271-4128-	Taper Pin Assortment	1 AT	N2
6685-00-226-8150-	Temperature Ind Cmpd, 200°F	12 EA	N
6685-00-269-4892-	Temperature Ind Cmpd, 400°F	12 EA	N
4910-00-317-8265	Test Set, Diesel Injector	1 SE	O, P
6630-00-105-1418-	Tester, Antifreeze & Battery	1 EA	N2
4910-00-808-4300	Tester, Cylinder Compression	1 EA	M
5136-00-596-1227	Thread Cutter, Die Head, Hand	1 SE	L
5180-00-317-8263	Thd Set, Scr, NC-NF, 1/4-1/2 In	1 SE	B
5180-00-698-7972	Thd Set, Scr, NC-NF, 9/16-1 In	1 SE	M
5180-00-293-2896-	Thd Set, Scr, NC-NF, No. 4-12	1 SE	N2
5140-00-319-5079	Tool Box, 20-5/16X8-9/16X13-1/2	1 EA	O
5140-00-315-2758	Tool Box, 22 X 8-1/2 X 9-1/2	1 EA	O
5140-00-289-8910-	Tool Box, 22 X 10-1/2 X 13	1 EA	N
5140-00-388-3416	Tool Box, 26 X 13 X 15	1 EA	N
5180-00-699-5273	Tool Kit, General Mechanic's	1 SE	U
5180-00-460-2177-	Tool Kit, Pin Remove & Replace	1 EA	I
5180-00-051-5024	Tool Kit, Thd Inst, 1/2-13	1 KT	N3
5180-00-054-7503-	Tool Kit, Thd Inst, 7/16-14	1 KT	N3
5180-00-054-7526-	Tool Kit, Thd Inst, 12-24	1 EA	N3
5180-00-935-0730-	Tool Kit, Thd Inst, 8-32	1 EA	N3
5180-00-935-0731-	Tool Kit, Thd Inst, 10-24	1 EA	N3
5180-00-935-0732-	Tool Kit, Thd Inst, 1/4-20	1 EA	N3
5180-00-935-0733-	Tool Kit, Thd Inst, 5/16-18	1 EA	N3
5180-00-935-0734-	Tool Kit, Thd Inst, 3/8-16	1 EA	N3
5180-00-935-4600-	Tool Kit, Scr Thd Insr, 14-1.25mm	1 EA	N2
3433-00-294-6743-	Torch Set, Cut, Weld	1 SE	M
4940-00-528-9145-	Tray, Shop Maintenance	1 EA	N2
4910-00-262-0392-	Trestle, Motor Vehicle	4 EA	P
5120-00-247-0864-	Tweezers, Craftman's, Genl Prp	1 EA	0
5120-00-293-0149-	Tweezers, Craftman's, Self cl	1 EA	0
3460-00-725-5076-	V-Blocks, Matched Pair	1 PR	N
4820-00-281-8190-	Valve, Rgltr, Fl Press Acet	1 EA	C
4820-00-641-3519	Valve, Rgltr, Fl Press Oxy	1 EA	C
5120-00-243-9072-	Vise, Bench and Pipe	1 EA	Q
5120-00-221-1122-	Vise, Bench, Clamp Base	1 EA	E
5120-00-243-1350-	Vise, Hand	1 EA	N2
3460-00-277-3504-	Vise, Machine Table	1 EA	C
5120-00-293-1439-	Vise, Machinist's	1 EA	P

NSN	DESCRIPTION	QTY.	LOC.
5310-00-514-6524	Washer, Assortment	1 AT	H1
5130-00-049-7912	Wheel Abrasive, Special	6 EA	N2
3460-00-517-5916	Wheel Abrasive, Al Oxd, 24 Gr	1 EA	E
3460-00-529-5446	Wheel Abrasive, Al Oxd, 46 Gr	1 EA	H1
6145-00-643-0956	Wire, Electrical	2 LB	H1
5315-00-271-4251	Woodruff Key Assortment	1 AT	H1
5120-00-224-3136	Wrench, Box 1/2 & 9/16 In	1 EA	H1
5120-00-288-9302	Wrench, Box, 5/8 & 3/4 In	1 EA	H1
5120-00-536-0013	Adapter, Torque Wrench	1 EA	H1
5130-01-087-6841	Wrench, Impact, Electric	1 EA	M
5120-00-240-5328	Wrench, Adjustable, 8 In	3 EA	H1
5120-00-277-6471	Wrench, Adjustable, 24 In	1 EA	0
5120-00-277-8301	Wrench, Open End	1 EA	H1
5120-00-277-7025	Wrench, Open End	1 EA	H1
5120-00-277-1191	Wrench, Open End	1 EA	H1
5120-00-277-1478	Wrench, Pipe, Adj, 14 In L	1 EA	H1
5120-00-277-1481	Wrench, Pipe, Adj, 35 In L	1 EA	L
5120-00-277-1483	Wrench, Pipe, Adj, 6 In L	1 EA	N
5120-00-293-0316	Wrench, Spanner, 5-12 In Dia	1 EA	L
5120-00-494-1929	Wrench, Torque & Rgltr	1 EA	E
5120-00-958-6906	Wrench, Torque, 3/8 In Sq Dr	1 EA	H1
x5120-00-821-3441	Wrench, Torque, 3/8 In Sq Dr	1 EA	H1
5120-00-542-5577	Wrench, Torque, 3/4 In Sq Dr	1 EA	H1
5120-00-640-6364	Wrench, Torque, 1/2 In Sq Dr	1 EA	B
5130-00-529-1147	Wrench Set, Socket, Impact	1 EA	C
5120-00-148-7917	Wrench Set, Box & Open End	1 SE	L
5120-00-203-5384	Wrench Set, Fixed, 15 Deg	1 SE	H1
5120-00-962-7580	Wrench Set, Open End	1 SE	N
5120-00-081-2309	Wrench Set, Skt, 1 In Sq Dr	1 SE	U
5120-00-204-1999	Wrench Set, Skt, 3/4 In Sq Dr	1 SE	N
4730-00-603-5184	Y-Outlet Connection	1 EA	N



## APPENDIX C

## EXPENDABLE/CONSUMABLE MAINTENANCE SUPPLIES AND MATERIALS

Item	Description	Ref. No. FSCM	NSN
1	LUBRICATING OIL: OE/HDO 30 OE/HDO 10 OES	MIL-L-2104 MIL-L-2104 MIL-L-10295	9150-00-265-9435 9150-00-269-9428 9150-00-242-7603
2	GREASE AUTOMOTIVE GAA	MIL-G-10924	9150-00-190-0904
3	BRAKE FLUID, AUTOMOTIVE HBA		9150-00-252-6375
4	HYDRAULIC FLUID OHA	MIL-H-5606	9150-00-223-4134
5	ANTIFREEZE Glycol, inhibited Arctic grade		6850-00-243-1992 6850-00-174-1806
6	FUEL. OIL DIESEL DF2, Regular grade DFL, Winter grade DFA, Arctic grade	VV-F-800 VV-F-800 VV-F-800	9140-00-286-5294 9140-00-286-5286 9140-00-286-5283





INDEX

	Paragraph	Page
<b>A</b>		
AC voltage adjusting rheostat . . . . .	2-2v	2-5
	18-19	18-16
AC voltmeter . . . . .	2-2t	2-5
	18-8	18-12
Administrative storage . . . . .	1-3	1-1
Airbrake chamber . . . . .	19-10	19-11
Air cleaner assembly. . . . .	11-2	11-1
Air cleaner service, compressor inlet . . . . .	3-13	3-13
Air cleaner service, engine . . . . .	3-8	3-12
Air compressor		
Disassembly . . . . .	14-10	14-8
Drive motor assembly. . . . .	14-3	14-1
Operation. . . . .	2-5f	2-17
Removal and installation . . . . .	14-2	14-1
Starter control box. . . . .	14-7	14-5
Air compressor inlet filter . . . . .	3-13	3-13
Air pressure gage. . . . .	2-2P	2-5
Air receiver tank pop-off valve . . . . .	14-6	14-3
Air reservoir tank. . . . .	19-8	19-9
Alternator . . . . .	7-4	7-13
Armature and bearings. . . . .	13-9	13-12
<b>B</b>		
Batteries . . . . .	7-2	7-1
Batteries, servicing . . . . .	3-7	3-12
Battery alternator voltage indicator . . . . .	2-2k	2-4
Battery switch . . . . .	2-2e	2-1
Bearing cap . . . . .	13-8	13-10
Belt guard assembly . . . . .	14-11	14-20
Belt tightener and base assembly . . . . .	14-12	14-20
Bleeding hydraulic brake system . . . . .	19-11	19-11
Body enclosure components . . . . .	3-14	3-14
Brake adjustment . . . . .	19-6	19-7
Brake air lines and fittings . . . . .	19-9	19-11
Brake lining replacement . . . . .	19-13	19-21
Brake shoes . . . . .	19-12	19-18
Brush holders . . . . .	13-10	13-14
<b>C</b>		
Cabinet assembly . . . . .	15-16	15-15
Camshaft . . . . .	12-5	12-20
Canvas walls, roofing, and deflector . . . . .	3-14c	3-14
Ceiling and blackout light . . . . .	6-5	6-16
Circuit breaker, control . . . . .	2-2ab	2-8
	18-13	18-13
Circuit breakers, 120V, single-phase . . . . .	2-2y	2-8
Circuit breakers, 240V, single-phase . . . . .	2-2ac	2-8
Circuit breakers, 240V, 3 phase . . . . .	2-2ae	2-9
Clearance lights. . . . .	6-10	6-24

	Paragraph	Page
<b>C-Continued</b>		
Clutch . . . . .	12-12	12-39
Composite light assembly . . . . .	6-11	6-25
Control cabinet . . . . .	18-20	18-16
Control cubicle, removal and installation. . . . .	5-4	5-5
Controls and instruments . . . . .	2-2	2-1
Convenience receptacles, lamp bases and toggle switches . . . . .	6-3	6-14
Coolant temperature gage . . . . .	2-21	2-4
Coolant temperature transmittier . . . . .	7-4	7-27
Crankshaft, connecting rods, and pistons. . . . .	12-10	12-26
Cylinder block assembly. . . . .	12 -11	12-38
Cylinder head and rocker arm assembly . . . . .	12-4	12-10
<b>D</b>		
Data . . . . .	1-7	1-1
DC ammeter . . . . .	2-2af 18-18	2-9 18-15
DC ampere selector switch . . . . .	2-2ah	2-9
DC ampere adjusting rheostat . . . . .	2-2ai 18-10	2-9 18-12
DC voltmeter . . . . .	2-2aj 18-15	2-9 18-14
Description . . . . .	1-6	1 - 1
Destruction of Army materiel to prevent enemy use . . . . .	1-5	1-1
Detailed lubrication information . . . . .	3-2	3-1
Dismantling for movement . . . . .	4-10	4-18
Door seals . . . . .	15-4	15-5
Doors and hinges . . . . .	15-1	15-1
Drill press operation. . . . .	2-5h	2-18
Drilling machine . . . . .	15-9	15-6
Dynamotor start/stop switch . . . . .	2-2u	2-5
Dynamotor-welder		
Brush replacement . . . . .	13-4	13-3
Removal and installation . . . . .	5-3	5-3
Servicing . . . . .	3-16	3-15
Switch . . . . .	18-9	18-12
<b>E</b>		
Emergency power panel . . . . .	18-4	18-7
Emergency power receptacle . . . . .	6-8	6-21
Emergency relay valve . . . . .	19-7	19-9
End covering . . . . .	13-8	13-10
End wrappers . . . . .	13-3	13-2
Engine assembly . . . . .	12-1	12-1
Engine cooling system. . . . .	9-1	9-1
Engine electrical system . . . . .	7-1	7-1
Engine enclosure, removal and installation . . . . .	5-1 19-19	5-1 19-31
Engine fuel system. . . . .	8-1	8-1

**E-Continued**

Engine . . . . .	18-20	18-21
Engine lubrication system . . . . .	10-1	10-1
Engine, removal and installation . . . . .	5-2	5-3
Engine starter ignition switch . . . . .	2-2d	2 - 1
Erecting tenting . . . . .	4-8d	4-6
Equipment conversion . . . . .	4-9	4-6
Exciter booster . . . . .	18-5	18-10
Exhaust manifold . . . . .	11-5	11-4
Expendable/consumable maintenance supplies and materials . . . . .		
External power connection . . . . .	4-8e	4-6
External power receptacle . . . . .	6-9	6-23

**F**

Fabricated tools and equipment . . . . .	4-3	4-1
Fan and water pump assembly . . . . .	9-6	9-7
Fan belt . . . . .	9-5	9-6
Field coils . . . . .	13-10	13-14
Fire extinguisher operation . . . . .	2-6	2-19
Floodlights . . . . .	6-4	6-14
Flow control valve hydraulic . . . . .	17-2	17-1
Flywheel and flywheel housing . . . . .	12-2	12-2
Frame brackets . . . . .	19-20	19-37
Frame end cover . . . . .	14-10	14-7
Frame suspension and axle assembly . . . . .	19-15	19-21
Frame wiring . . . . .	19-23	19-37
Frequency meter . . . . .	2-2x	2-8
	18-11	18-13
Frequency switch . . . . .	2-2w	2-5
	18-12	18-13
Front ladder . . . . .	19-22	19-37
Front ventilator fan assembly . . . . .	6-6	6-18
Fuel filter, secondary . . . . .	3-9	3-12
Fuel injection nozzle holders and lines . . . . .	8-7	8-37
Fuel injection pump . . . . .	8-6	8-7
Fuel level gage . . . . .	2-2j	2-4
Fuel tank, lines, and fittings . . . . .	8-2	8-1
Fuel transfer pump . . . . .	8-3	8-4

**G**

Gear housing and cover . . . . .	12-3	12-6
General maintenance . . . . .	4-17	4-36
Generator output contactor . . . . .	18-2	18-3
Grinder . . . . .	15-5	15-5
Grounding shop set . . . . .	4-8f	4-6

	Paragraph	Page
H		
High coolant temperature warning light . . . . .	2-2m	2-4
Hinged table . . . . .	15-15	15-14
Hub breakdown and wheel bearings . . . . .	19-5	19-4
Hydraulic systems . . . . .	2-2a	2-1
I		
Identification . . . . .	1-7a	1-1
Inlet air filter . . . . .	14-5	14-5
Inspecting and servicing equipment , , , . . . . .	4-6	4-1
Installation of separately packed components . . . . .	4-7	4-4
Installation or setting-up instructions . . . . .	4-8	4-4
Instrument panel lights . . . . .	2-2b	2-1
Intake and exhaust systems . . . . .	11-1	11-1
Intake manifold . . . . .	11-4	11-4
Interference suppression components , , . . . . .	4-19	4-36
J		
Junction box (24 V circuit) . . . . .	6-12	6-26
L		
Landing gear . . . . .	19-18	19-27
Lathe . . . . .	15-13	15-12
Lathe belt . . . . .	15-12	15-11
Lathe operation . . . . .	2-5g	2-17
Location and leveling . . . . .	4-8g	4-4
Low oil pressure warning light . . . . .	2-2o	2-5
Lube oil filter, servicing . . . . .	3-12	3-13
Lubrication . . . . .	3-1	3-1
	4-12	4-18
M		
Maintenance allocation chart . . . . .		B-1
Maintenance forms and records . . . . .	1-2	1-1
Maintenance of air compressor and related parts . . . . .	14-1	14-1
Maintenance of control cubicle . . . . .	18-1	18-1
Maintenance of dynamotor-welder , , . . . . .	13-1	13-1
Manual shutdown control . . . . .	2-2g	2-4
Mill operation . . . . .	2-5i	2-18
Milling and grinding attachment , , , . . . . .	15-6	15-6
Miscellaneous van body components . . . . .	15-18	15-17

Paragraph Page

M - Continued

Motor assembly, air compressor drive . . . . .	14-3	14-1
Mounting rings . . . . .	13-10	13-14
Muffler . . . . .	11-3	11-1

O

Oil filter assembly . . . . .	10-2	10-1
Oil pan assembly . . . . .	10-3	10-4
Oil pressure gage . . . . .	2-2n	2-4
Oil pressure sending units . . . . .	7-5	7-29
Oil pump assembly . . . . .	10-4	10-4
On equipment electrical tests . . . . .	13-6	13-9
Opening shop set . . . . .	4-8c	4-6
Operating procedures . . . . .	2-1	2-1
Operation at high altitudes . . . . .	2-13	2-21
Operation in dusty or sandy areas . . . . .	2-10	2-20
Operation in extreme cold . . . . .	2-8	2-19
Operation in extreme heat . . . . .	2-9	2-20
Operation in saltwater areas . . . . .	2-12	2-21
Operation of equipment . . . . .	2-5	2-11
Operation on emergency power . . . . .	2-5c	2-14
Operation on external (CITY) power . . . . .	2-5b	2-14
Operation on internal power . . . . .	2-5a	2-11
Operation under rainy or humid conditions . . . . .	2-11	2-21
Operation with power-selector in OFF . . . . .	2-5d	2-16
Operator/crew maintenance . . . . .	3-6	3-12
Overload switch . . . . .	18-3	18-6
Overspeed safety switch . . . . .	2-2ak	2-9
	13-5	13-3

P

Personnel heater . . . . .	2-7	2-19
	16-1	16-1
Pivot axle . . . . .	19-17	19-24
Polarity switch . . . . .	2-2ag	2-9
	18-17	18-15
Pole shoes . . . . .	13-10	13-14
Power selector switch . . . . .	2-2aa	2-8
	18-6	18-10
Press frame, 17½ ton . . . . .	15-8	15-6
Pressure switch, air compressor . . . . .	2-2r	2-5
	14-4	14-1
	14-8	14-6
Preventive maintenance checks and services . . . . .	3-3	3-1
	4-13	4-19
Primary fuel filter . . . . .	8-4	8-5
Primer . . . . .	2-2h	2-4

Q

Quick start system . . . . . 8-8 8-42

R

Radiator, draining, flushing, and  
 refilling . . . . . 9-3 9-5

Radiator, maintenance . . . . . 9-2 9-1

Radiator, servicing . . . . . 3-11 3-12

Radiator hoses and tubing . . . . . 9-4 9-6

Radio interference suppression . . . . . 4-18 4-36

Rear ventilator fan assembly . . . . . 6-7 6-19

Rear wiring to floodlight . . . . . 6-13 6-28

Receptacles, 120V, single-phase . . . . . 2-2z 2-8  
 2-5j 2-18  
 18-14 18-14

Receptacles, 240V, single-phase . . . . . 2-2ad 2-8  
 2-5k 2-18  
 18-14 18-14

References . . . . . A-1 A-1

Reinstallation after movement . . . . . 4-11 4-18

Relief valve . . . . . 2-2q 2-5

Repair parts . . . . . 4-1 4-1

Reporting equipment improvement recommendations  
 (EIR) . . . . . 1-4 1-1

Resistor and relay mounting panel . . . . . 18-4 18-7

Rotary switch (10-RANGE) . . . . . 18-1 18-1

Running time meter . . . . . 18-16 18-14

S

Scope . . . . . 1-1 1-1

Secondary fuel filter . . . . . 8-5 8-7

Service and blackout clearance lights . . . . . 6-2 6-1

Service upon receipt of material . . . . . 4-4 4-1

Shop body, removal and installation . . . . . 5-5 5-5

Shutter control . . . . . 2-2i 2-4

Side lifting cylinders and hydraulic lines . . . . . 17-4 17-3  
 17-5 17-5

Side lifting hydraulic pumps . . . . . 17-3 17-1  
 17-6 17-7

Side lifting hydraulic system . . . . . 3-15 3-15

Sparkplug cleaner . . . . . 15-10 15-9

Special tools and equipment . . . . . 4-1 4-1

Speed adjustment for 60 hertz AC output . . . . . 2-3c 2-11

Springs . . . . . 19-14 19-21

Start, stop, and reset switch . . . . . 2-2s 2-5

Starter assembly . . . . . 7-3 7-4

s - Continued

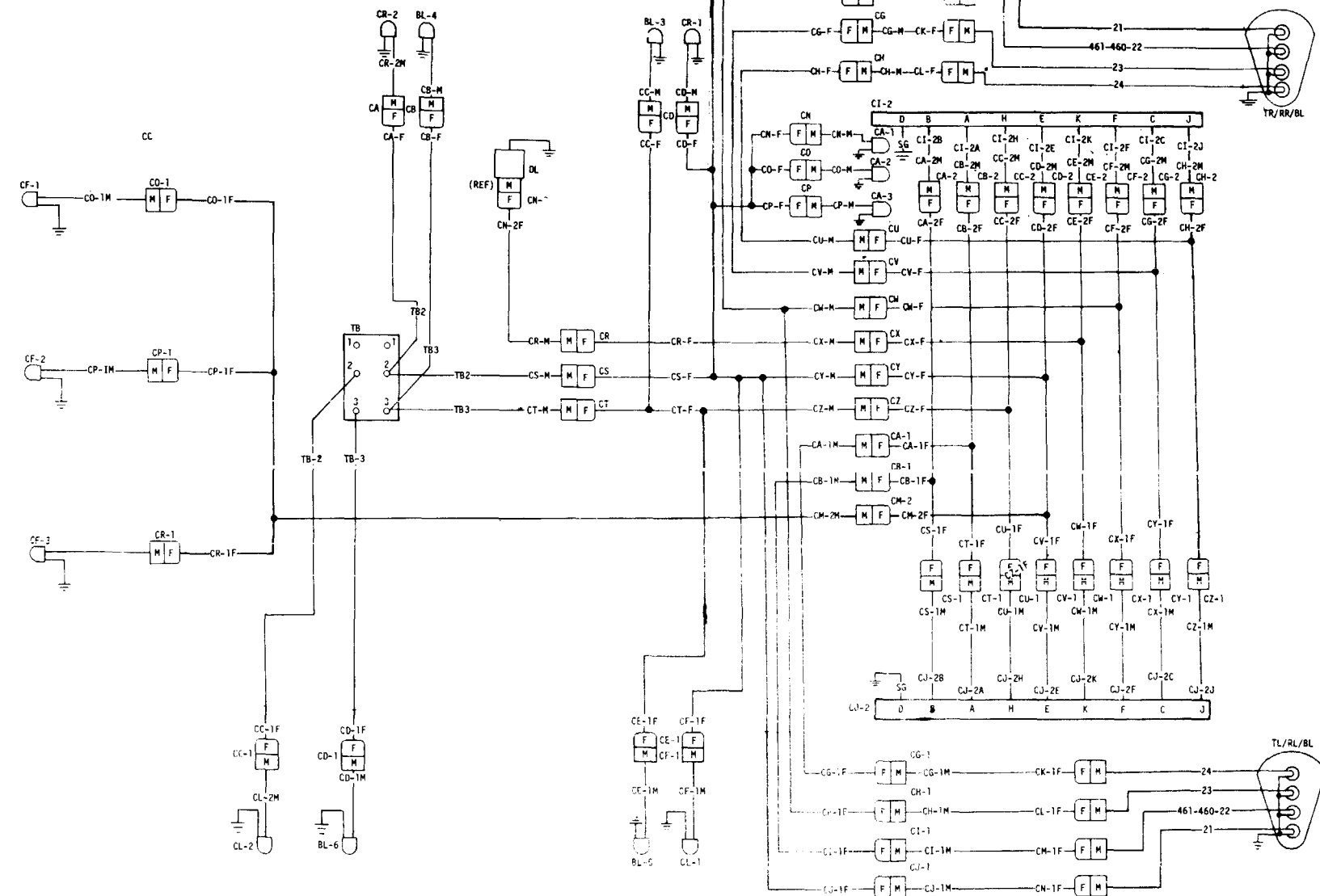
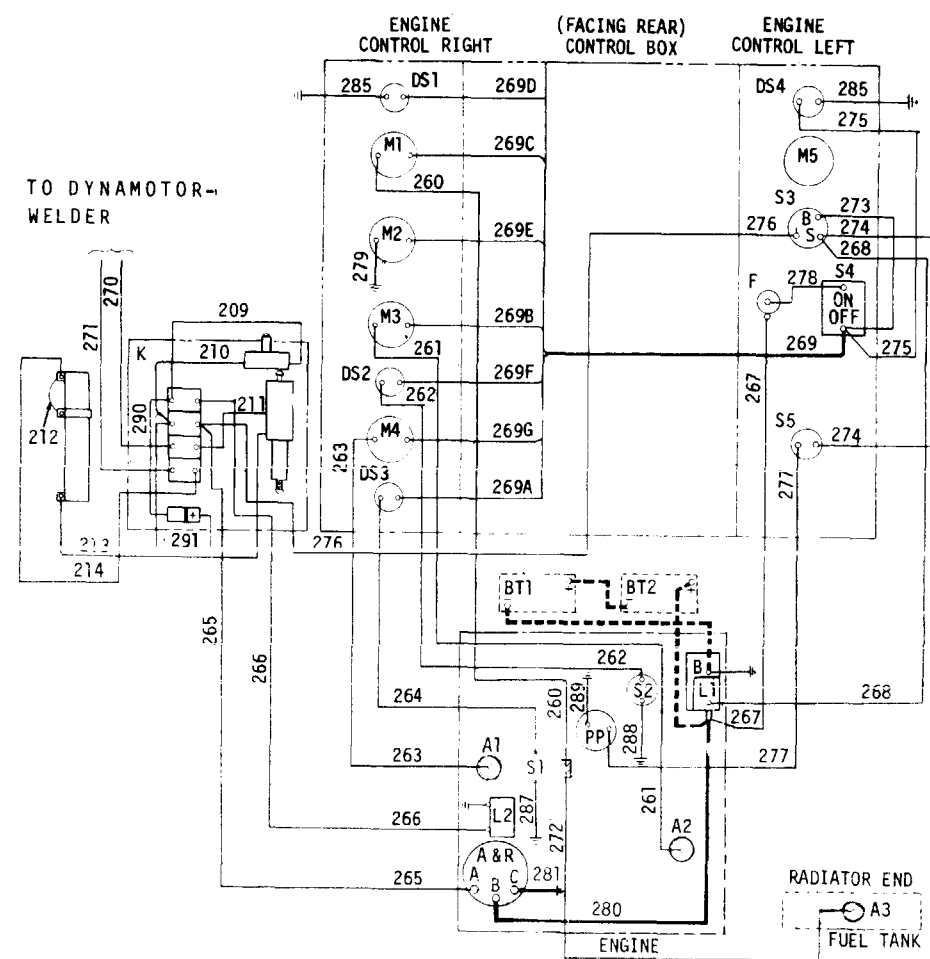
Starter control box, compressor . . . . .	14-7	14-5
Starting aid, servicing . . . . .	3-10	3-12
Starting the engine . . . . .	2-3	2-9
Stopping the engine . . . . .	2-4	2-11

T

Tables, welder and lathe . . . . .	15-14	15-12
Tabulated data . . . . .	1-7b	1-5
Tachometer . . . . .	2-2c	2-1
Tent frame . . . . .	3-14b	3-14
	15-2	15-3
Terminal boards . . . . .	13-10	13-20
Testing airbrake system for leaks . . . . .	19-3	19-2
Testing of suppression components . . . . .	4-21	4-37
Throttle control . . . . .	2-2f	2-1
Tires and wheels maintenance . . . . .	19-4	19-3
Tool location loading and packing list . . . . .		B-1
Torque rods . . . . .	19-16	19-24
Towing pintle . . . . .	19-21	19-31
Track and trolley assembly . . . . .	15-17	15-16
Trailer chassis and components . . . . .	19-1	19-1
Troubleshooting . . . . .	3-5	3-5
	4-16	4-19



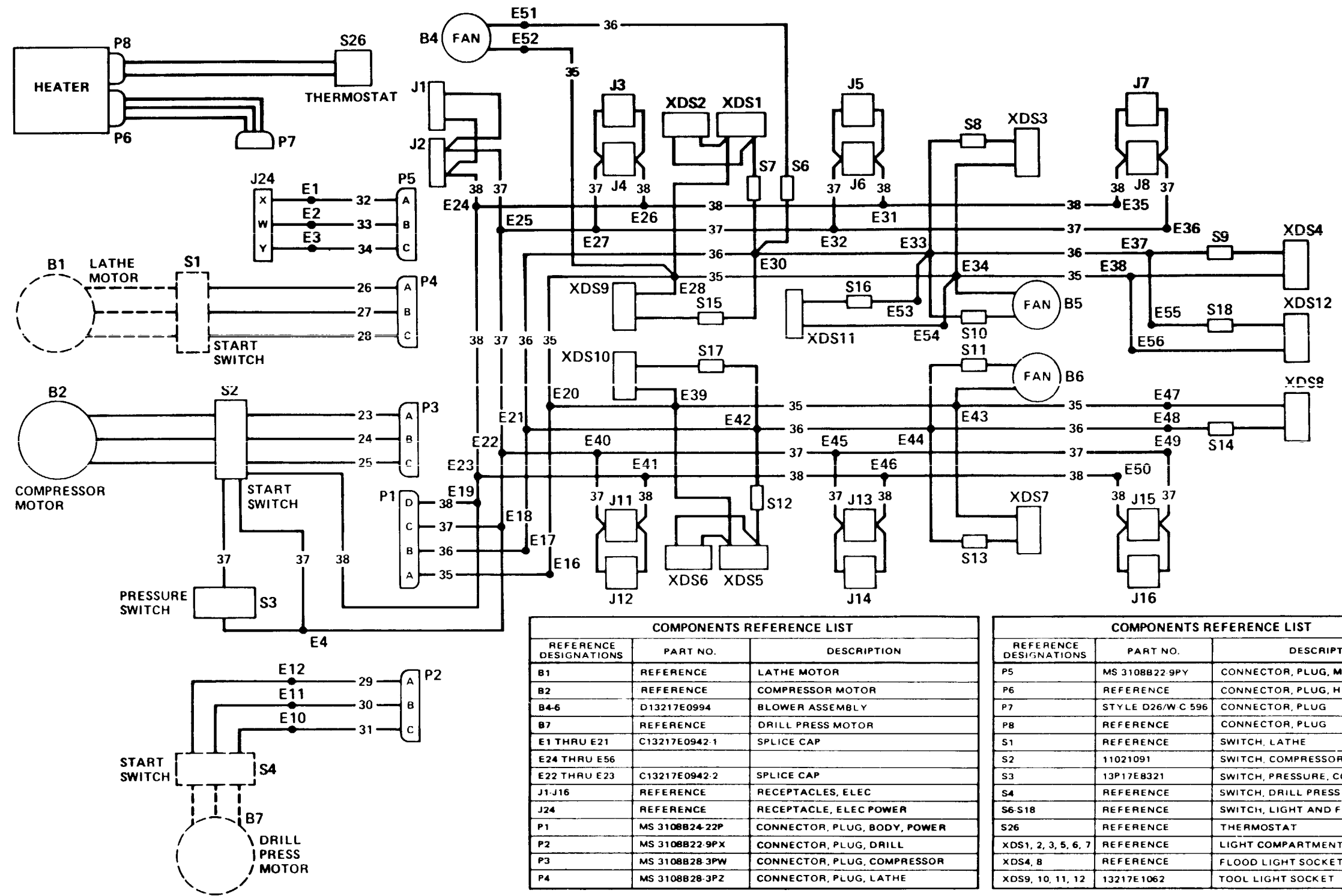




LEGEND			
A1	OIL PRESSURE SENDING UNIT	L2	FUEL PUMP SOLENOID VALVE
A2	WATER TEMP. SENDING UNIT	M1	FUEL GAGE
A3	FUEL TANK SENDING UNIT	M2	BATTERY VOLTAGE INDICATOR
A & R	ALTERNATOR & REGULATOR	M3	TEMPERATURE GAGE
B	STARTER	M4	OIL PRESSURE GAGE
BT1, BT2	BATTERIES	M5	TACHOMETER
DS1, DS4	PILOT LIGHTS	PP	ETHER PRIMER PUMP
DS2	TEMP. WARNING LIGHT	S1	OIL PRESSURE SWITCH (CLOSED BELOW PRESSURE)
DS3	OIL PRESSURE WARNING LIGHT	S2	WATER TEMP. THERMO SWITCH (OPEN BELOW EXCESSIVE TEMPERATURE)
F	FUSE	S3	KEY LOCK STARTER SWITCH
K	OVERSPEED RELAY	S4	ON-OFF BATTERY SWITCH
L1	STARTER SOLENOID	S5	PRIMER PUSH BUTTON

COMPONENTS REFERENCE LIST	
REFERENCE DESIGNATIONS	DESCRIPTION
BL-3, BL-5	LIGHT, MARKER, CLEARANCE, BLACKOUT, RED
BL-4, BL-6	LIGHT, MARKER, CLEARANCE, BLACKOUT, AMBER
CA-F THRU CS-F	CONNECTOR, PLUG, ELEC, FEMALE
CC-1 THRU CR-1F, CM-2F	CONNECTOR, PLUG, ELEC, FEMALE
CA-M THRU CS-M	CONNECTOR, PLUG, ELEC, MALE
CU-M THRU CR-1M, CM-2M	CONNECTOR, PLUG, ELEC, MALE
CA-1, CA-2, CA-3	LIGHT, MARKER, AFT, CLEARANCE, SERVICE, RED
CF-1, CF-2, CF-3	LIGHT, MARKER, FWD, CLEARANCE, SERVICE, AMBER
CL-1, CR-1	LIGHT, MARKER, CLEARANCE, SERVICE, RED
CL-2, CR-2	LIGHT, MARKER, CLEARANCE, SERVICE, AMBER
ON-2M(REF)	CONNECTOR, PLUG, ELEC, MALE
DL	DOME LIGHT
TB	TERMINAL BOARD, MIL-T-55164/2
TL/RL/BL	COMPOSITE LIGHT-TAIL, STOP, TURN AND MARKER
TR/RR/BL	COMPOSITE LIGHT-TAIL, STOP, TURN AND MARKER

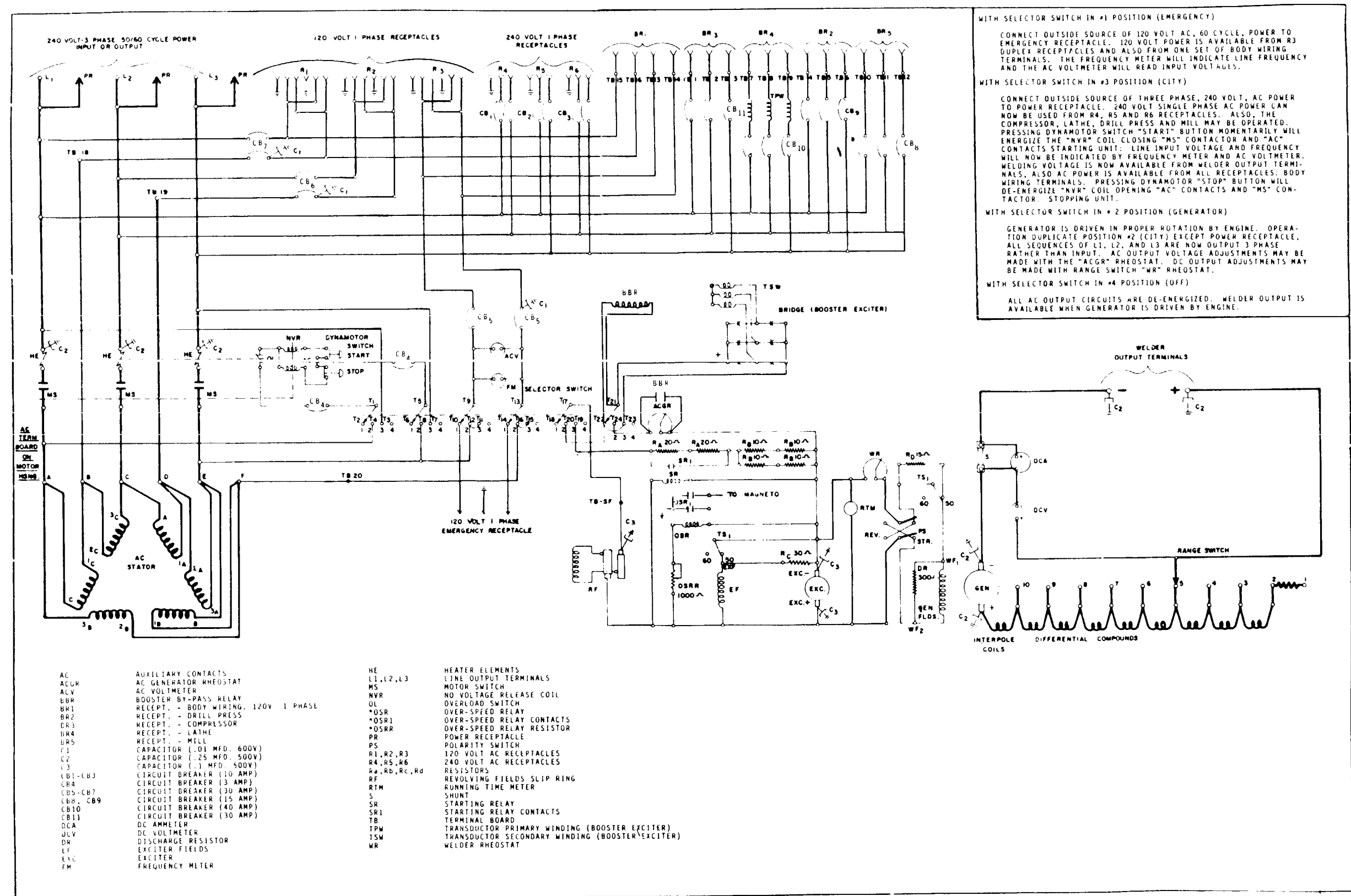
Figure FO-1. Engine and 24 Vdc Body Wiring Diagram.



REFERENCE DESIGNATIONS	PART NO.	DESCRIPTION
B1	REFERENCE	LATHE MOTOR
B2	REFERENCE	COMPRESSOR MOTOR
B4-6	D13217E0994	BLOWER ASSEMBLY
B7	REFERENCE	DRILL PRESS MOTOR
E1 THRU E21	C13217E0942.1	SPLICE CAP
E24 THRU E56		
E22 THRU E23	C13217E0942.2	SPLICE CAP
J1-J16	REFERENCE	RECEPTACLES, ELEC
J24	REFERENCE	RECEPTACLE, ELEC POWER
P1	MS 3108B24-22P	CONNECTOR, PLUG, BODY, POWER
P2	MS 3108B22-9PX	CONNECTOR, PLUG, DRILL
P3	MS 3108B28-3PW	CONNECTOR, PLUG, COMPRESSOR
P4	MS 3108B28-3PZ	CONNECTOR, PLUG, LATHE

REFERENCE DESIGNATIONS	PART NO.	DESCRIPTION
P5	MS 3108B22-9PY	CONNECTOR, PLUG, MILLING MACHINE
P6	REFERENCE	CONNECTOR, PLUG, HEATER
P7	STYLE D26/W C 596	CONNECTOR, PLUG
P8	REFERENCE	CONNECTOR, PLUG
S1	REFERENCE	SWITCH, LATHE
S2	11021091	SWITCH, COMPRESSOR, STARTER
S3	13P17E8321	SWITCH, PRESSURE, COMPRESSOR
S4	REFERENCE	SWITCH, DRILL PRESS
S6-S18	REFERENCE	SWITCH, LIGHT AND FAN
S26	REFERENCE	THERMOSTAT
XDS1, 2, 3, 5, 6, 7	REFERENCE	LIGHT COMPARTMENT SOCKET
XDS4, 8	REFERENCE	FLOOD LIGHT SOCKET
XDS9, 10, 11, 12	13217E1062	TOOL LIGHT SOCKET

Figure F0-2. 110/220 Vac Body Wiring Diagram. F0-3/(F0-4blank)



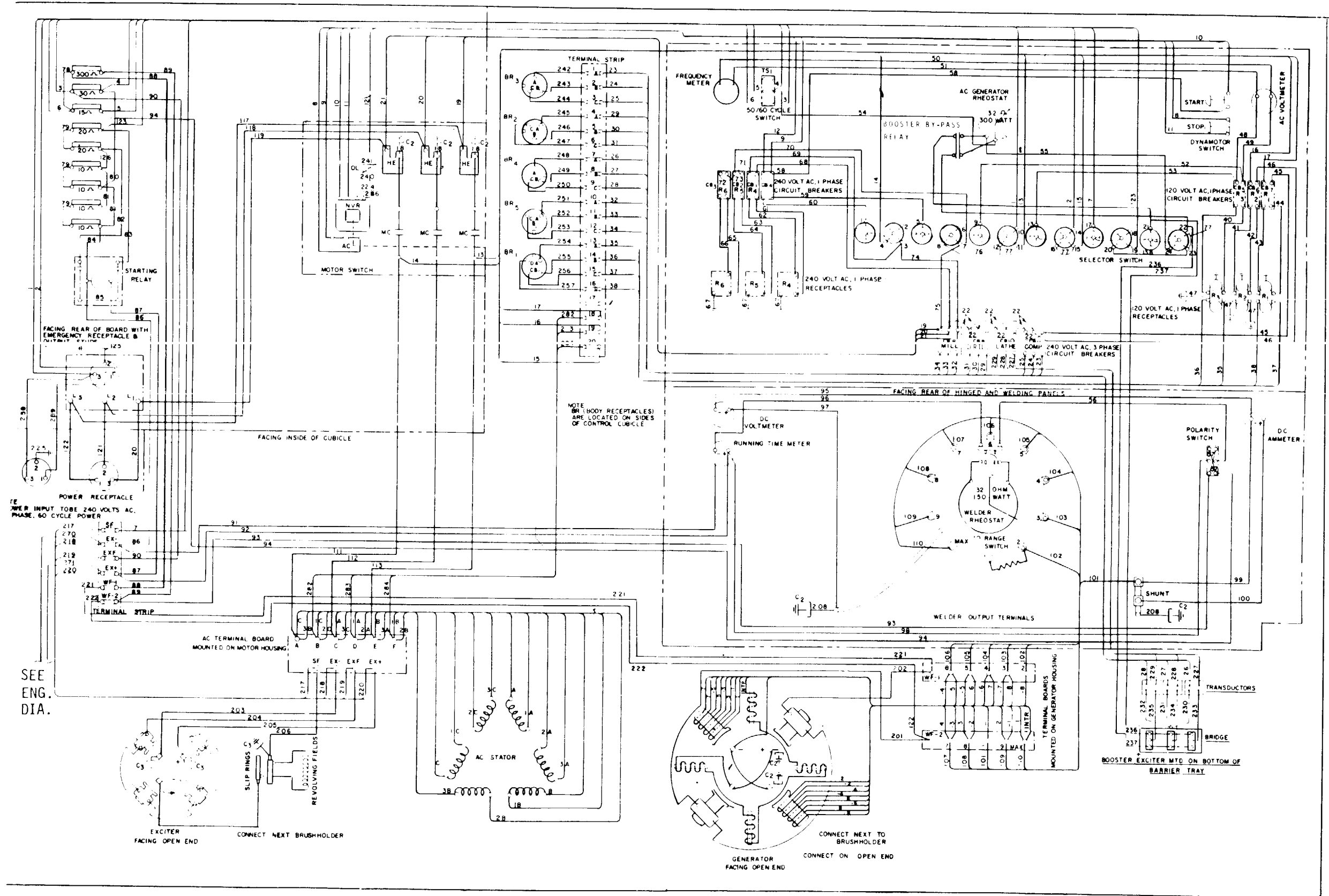


Figure FO-4. Dynamotor-Welder Schematic Diagram. FO-7/(FO-8blank)

By Order of the Secretary of the Army:

JOHN A. WICKHAM, JR.  
*General, United States Army*  
*Chief of Staff*

Official:

ROBERT M. JOYCE  
*Major General, United States Army*  
*The Adjutant General*

DISTRIBUTION : To be distributed in accordance with DA Form 12-21A,  
quantity required block 544, requirement for Semitrailer Mounted.



RECOMMENDED CHANGES TO EQUIPMENT TECHNICAL PUBLICATIONS

**SOMETHING WRONG WITH THIS PUBLICATION?**



THEN... JOT DOWN THE DOPE ABOUT IT ON THIS FORM. CAREFULLY TEAR IT OUT, FOLD IT AND DROP IT IN THE MAIL!

FROM: (PRINT YOUR UNIT'S COMPLETE ADDRESS)

Your Address

DATE SENT

(date you filled out)

PUBLICATION NUMBER  
TM 9-4940-549-14&P

PUBLICATION DATE

PUBLICATION TITLE Shop Equipment,  
General Purpose Repair, Semitrailer  
Mounted Model SGPRSM

BE EXACT... PIN-POINT WHERE IT IS

PAGE NO	PARA-GRAPH	FIGURE NO	TABLE NO
8-5			

IN THIS SPACE TELL WHAT IS WRONG AND WHAT SHOULD BE DONE ABOUT IT:

NSN should be 4940-00-892-7446, not 5940-00-892-7446.

SAMPLE

PRINTED NAME, GRADE OR TITLE, AND TELEPHONE NUMBER

Your Name

SIGN HERE:







FILL IN YOUR  
UNIT'S ADDRESS



FOLD BACK

DEPARTMENT OF THE ARMY

---

---

OFFICIAL BUSINESS  
PENALTY FOR PRIVATE USE \$300

POSTAGE AND FEES PAID  
DEPARTMENT OF THE ARMY  
DOD 314



Commander  
US Army Armament, Munitions & Chemical Command  
ATTN: DRSMC-MAS  
Rock Island, IL 61299

FOLD BACK



THEN... JOT DOWN THE DOPE ABOUT IT ON THIS FORM, CUT IT OUT, FOLD IT AND DROP IT IN THE MAIL!

# SOMETHING WRONG WITH THIS MANUAL?

FROM: (YOUR UNIT'S COMPLETE ADDRESS)

DATE

PUBLICATION NUMBER

TM 9-4940-549-14&P

DATE

12 Mar 84

Shop Equipment, General Purpose Repair, Semitrailer Mtd Model SGPRSM (NSN 4940-01-006-3229)

BE EXACT. . . PIN-POINT WHERE IT IS

IN THIS SPACE TELL WHAT IS WRONG

PAGE NO.	PARA-GRAPH	FIGURE NO.	TABLE NO.

PRINTED NAME, GRADE OR TITLE, AND TELEPHONE NUMBER

SIGN HERE:

DA FORM 2028-2  
1 APR 78

REPLACES DA FORM 2028-2 (TEST), 1 AUG 74, WHICH WILL BE USED UNTIL EXHAUSTED.

P.S.—IF YOUR OUTFIT WANTS TO KNOW ABOUT YOUR MANUAL "FIND," MAKE A CARBON COPY OF THIS AND GIVE IT TO YOUR HEADQUARTERS.

DO NOT WRITE IN THESE SPACES

FILL IN YOUR  
UNIT'S ADDRESS



FOLD BACK

DEPARTMENT OF THE ARMY

\_\_\_\_\_  
\_\_\_\_\_

OFFICIAL BUSINESS  
PENALTY FOR PRIVATE USE \$300

POSTAGE AND FEES PAID  
DEPARTMENT OF THE ARMY  
DOD 314



Commander  
US Army Armament, Munitions & Chemical Command  
ATTN: DRSMC-MAS  
Rock Island, IL 61299

FOLD BACK



FILL IN YOUR  
UNIT'S ADDRESS

DEPARTMENT OF THE ARMY

OFFICIAL BUSINESS  
PENALTY FOR PRIVATE USE \$300

FOLD BACK

POSTAGE AND FEES PAID  
DEPARTMENT OF THE ARMY  
DOD 314



Commander  
US Army Armament, Munitions & Chemical Command  
ATTN: DRSMC-MAS  
Rock Island, IL 61299

FOLD BACK

## THE METRIC SYSTEM AND EQUIVALENTS

### LINEAR MEASURE

1 Centimeter = 10 Millimeters = 0.01 Meters = 0.3937 Inches  
 1 Meter = 100 Centimeters = 1000 Millimeters = 39.37 Inches  
 1 Kilometer = 1000 Meters = 0.621 Miles

### WEIGHTS

1 Gram = 0.001 Kilograms = 1000 Milligrams = 0.035 Ounces  
 1 Kilogram = 1000 Grams = 2.2 Lb  
 1 Metric Ton = 1000 Kilograms = 1 Megagram = 1.1 Short Tons

### LIQUID MEASURE

1 Milliliter = 0.001 Liters = 0.0338 Fluid Ounces  
 1 Liter = 1000 Milliliters = 33.82 Fluid Ounces

### SQUARE MEASURE

1 Sq Centimeter = 100 Sq Millimeters = 0.155 Sq Inches  
 1 Sq Meter = 10,000 Sq Centimeters = 10.76 Sq Feet  
 1 Sq Kilometer = 1,000,000 Sq Meters = 0.386 Sq Miles

### CUBIC MEASURE

1 Cu Centimeter = 1000 Cu Millimeters = 0.06 Cu Inches  
 1 Cu Meter = 1,000,000 Cu Centimeters = 35.31 Cu Feet

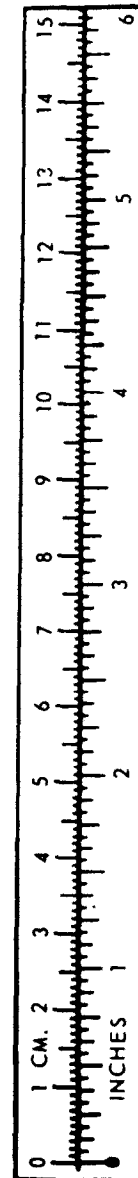
### TEMPERATURE

$5/9 (^{\circ}\text{F} - 32) = ^{\circ}\text{C}$   
 212<sup>o</sup> Fahrenheit is equivalent to 100<sup>o</sup> Celsius  
 90<sup>o</sup> Fahrenheit is equivalent to 32.2<sup>o</sup> Celsius  
 32<sup>o</sup> Fahrenheit is equivalent to 0<sup>o</sup> Celsius  
 $9/5 \text{ C}^{\circ} + 32 = \text{F}^{\circ}$

### APPROXIMATE CONVERSION FACTORS

<u>TO CHANGE</u>	<u>TO</u>	<u>MULTIPLY BY</u>
Inches . . . . .	Centimeters . . . . .	2.540
Feet . . . . .	Meters . . . . .	0.305
Yards . . . . .	Meters . . . . .	0.914
Miles . . . . .	Kilometers . . . . .	1.609
Square Inches . . . . .	Square Centimeters . . . . .	6.451
Square Feet . . . . .	Square Meters . . . . .	0.093
Square Yards . . . . .	Square Meters . . . . .	0.836
Square Miles . . . . .	Square Kilometers . . . . .	2.590
Acres . . . . .	Square Hectometers . . . . .	0.405
Cubic Feet . . . . .	Cubic Meters . . . . .	0.028
Cubic Yards . . . . .	Cubic Meters . . . . .	0.765
Fluid Ounces . . . . .	Milliliters . . . . .	29.573
Pints . . . . .	Liters . . . . .	0.473
Quarts . . . . .	Liters . . . . .	0.946
Gallons . . . . .	Liters . . . . .	3.785
Ounces . . . . .	Grams . . . . .	28.349
Pounds . . . . .	Kilograms . . . . .	0.454
Short Tons . . . . .	Metric Tons . . . . .	0.907
Pound-Feet . . . . .	Newton-Meters . . . . .	1.356
Pounds per Square Inch . . . . .	Kilopascals . . . . .	6.895
Miles per Gallon . . . . .	Kilometers per Liter . . . . .	0.425
Miles per Hour . . . . .	Kilometers per Hour . . . . .	1.609

<u>TO CHANGE</u>	<u>TO</u>	<u>MULTIPLY BY</u>
Centimeters . . . . .	Inches . . . . .	0.394
Meters . . . . .	Feet . . . . .	3.280
Meters . . . . .	Yards . . . . .	1.094
Kilometers . . . . .	Miles . . . . .	0.621
Square Centimeters . . . . .	Square Inches . . . . .	0.155
Square Meters . . . . .	Square Feet . . . . .	10.764
Square Meters . . . . .	Square Yards . . . . .	1.196
Square Kilometers . . . . .	Square Miles . . . . .	0.386
Square Hectometers . . . . .	Acres . . . . .	2.471
Cubic Meters . . . . .	Cubic Feet . . . . .	35.315
Cubic Meters . . . . .	Cubic Yards . . . . .	1.308
Milliliters . . . . .	Fluid Ounces . . . . .	0.034
Liters . . . . .	Pints . . . . .	2.113
Liters . . . . .	Quarts . . . . .	1.057
Liters . . . . .	Gallons . . . . .	0.264
Grams . . . . .	Ounces . . . . .	0.035
Kilograms . . . . .	Pounds . . . . .	2.205
Metric Tons . . . . .	Short Tons . . . . .	1.102
Newton-Meters . . . . .	Pound-Feet . . . . .	0.738
Kilopascals . . . . .	Pounds per Square Inch . . . . .	0.145
Kilometers per Liter . . . . .	Miles per Gallon . . . . .	2.354
Kilometers per Hour . . . . .	Miles per Hour . . . . .	0.621



TA089991

**TM 9-4940-549-14&P, SHOP EQUIPMENT, GENERAL PURPOSE REPAIR, SEMI-TRAILER MOUNTED  
(NSN 4940-01-006-3229)**